



CITY OF MARINE CITY

City Commission Meeting Agenda

Guy Community Center, 260 South Parker Street
Regular Meeting: Thursday, July 20, 2023; 7:00 PM

1. CALL TO ORDER

2. MOMENT OF SILENCE / PLEDGE OF ALLEGIANCE

3. **ROLL CALL:** Mayor Jennifer Vandenbossche; Commissioners Jacob Bryson, Elizabeth Hendrick, Michael Hilferink, William Klaassen, Rita Roehrig, Brian Ross; City Manager Scott Adkins.

4. APPROVE AGENDA

5. **PUBLIC COMMENT** Anyone is welcome to address the City Commission. Please state name and limit comments to five (5) minutes. This is a time for you to raise issues. The Commission will not respond, but issues will be followed up on as necessary.

6. APPROVE MINUTES

- a. City Commission Meeting Minutes – June 15, 2023

7. CONSENT AGENDA

- a. MCAFA Run Report
- b. Departmental Activity Monthly Reports
- c. 300 Broadway Meeting Minutes – May 22, 2023
- d. Zoning Board of Appeals Meeting Minutes – April 5, 2023
- e. Planning Commission Meeting Minutes – May 22, 2023
- f. Special Event Permit – Marine City Festival Inc., 2023 Maritime Days
- g. Special Event Permit – Community Pride and Heritage, Inc – Concert in the Park
- h. Special Event Permit – Marine City High School Homecoming Parade

8. ITEMS REMOVED FROM CONSENT AGENDA

9. FINANCIAL BUSINESS

- a. Expenditures (including payroll) – \$811,618.33
- b. Preliminary Financial Statements

10. UNFINISHED BUSINESS

- a. Recreational Marijuana Facilities Ballot Initiative Language Discussion

11. NEW BUSINESS

DISCUSSION ITEMS

ACTION ITEMS

- a. Maritime Days Fireworks Permit Approval
- b. Resolution 021-2023 – 457 Plan Administrator and Trustee
- c. Insurance Plan Renewal – Nickel & Saph

- d. City Clerk Agreement – Jason Bell
- e. Board Vacancy Appointments
 - i. Planning Commission – 3 Appointments
 - ii. TIFA – 1 Appointment
 - iii. Community Economic Development Board – 1 Business Representative Appointment
 - iv. MCAFA – 3 Appointments
- f. Board Vacancy Announcement
 - i. Library Board – 1 Vacancy
 - ii. Planning Commission -1 Vacancy
- g. SCADA Pump Station Technology Purchase
- h. DPW – Plow Truck Chassis Purchase
- i. DPW – Plow Truck Equipment Purchase
- j. DPW – Contract Approval Bio Material Disposal

12. ADMINISTRATIVE REPORTS

- a. City Attorney's Report
- b. City Manager's Report
- c. Reports from Department Heads

13. COMMISSIONER PRIVILEGE/LIAISON REPORTS

14. ADJOURNMENT

**City of Marine City
City Commission Minutes
June 15, 2023**

A regular meeting of the Marine City Commission was held on Thursday, June 15, 2023 at 260 South Parker Street, Marine City, and was called to order by Mayor Vandenbossche at 7:00 P.M.

Present: Mayor Jennifer Vandenbossche; Commissioners Jacob Bryson, Elizabeth Hendrick, Michael Hilferink, William Klaassen, Rita G. Roehrig, Brian Ross; City Manager Scott Adkins; Interim City Clerk Jason Bell.

Also Present: City Attorney Robert Davis

AUDIO/VIDEO AVAILABLE

For complete audio/video of meeting, visit the following link:

<https://www.youtube.com/watch?v=ntrecoB5Zzw>

APPROVE AGENDA

Motion by Commissioner Hendrick, seconded by Commissioner Klaassen, to approve the agenda with the correction of 9g being local street fund and 9h being major street fund and move 10d to 10a. Ayes: Vandenbossche, Hendrick, Hilferink, Klaassen, Roehrig, Ross, Bryson. Nays: None. Motion Carried.

PUBLIC COMMENT

None.

APPROVE MINUTES

Motion by Commissioner Bryson, seconded by Commissioner Klaassen, to approve the City Commission Meeting Minutes of June 1, 2023. All Ayes. Motion Carried.

Motion by Commissioner Ross, seconded by Commissioner Klaassen, to approve the City Commission Closed Session Meeting Minutes of June 1, 2023. All Ayes. Motion Carried.

Motion by Commissioner Bryson, seconded by Commissioner Roehrig, to approve the City Commission Special Meeting Minutes of June 1, 2023. All Ayes. Motion Carried.

CONSENT AGENDA

Presented:

- a. MCAFA Run Report
- b. Departmental Activity Monthly Reports
- c. Community and Economic Development Meeting Minutes – April 13, 2023

d. Business License – Lafontaine Collision of St. Clair

Motion by Commissioner Bryson, seconded by Commissioner Ross, to approve the Consent Agenda a-d. **Roll Call Vote.** Ayes: Bryson, Hendrick, Hilferink, Klaassen, Roehrig, Ross, Vandenbossche. Nays: None. Motion Carried.

ITEMS REMOVED FROM CONSENT AGENDA

None

FINANCIAL BUSINESS

Expenditures Including Payroll - \$500,620.93

Commissioner Hendrick inquired if the new server for City Offices was coming to the Commission for approval. City Manager Adkins stated the server was previously approved by the Commission but due to scheduling, was just recently installed.

Motion by Commissioner Bryson, seconded by Commissioner Klaassen, to approve expenditures including payroll in the amount of \$500,620.93. **Roll Call Vote.** Ayes: Hendrick, Hilferink, Klaassen, Roehrig, Ross, Vandenbossche, Bryson. Nays: None. Motion Carried.

Preliminary Financial Statements

Motion by Commissioner Hendrick, seconded by Commissioner Ross, to receive and file the preliminary financial statements. **Roll Call Vote.** Ayes: Hilferink, Klaassen, Roehrig, Ross, Vandenbossche, Bryson, Hendrick. Nays: None. Motion Carried.

Resolution 015-2023 - Budget Amendments

Commissioner Hendrick inquired if the amendments brought the Fiscal Year 2022/2023 Budget current and if the finances were in good shape. City Manager Adkins stated the amendments should be final.

Motion by Commissioner Bryson, seconded by Commissioner Klaassen, to approve Resolution 015-2023 to amend the Fiscal Year 2022/2023 Budget to adjust for changes in anticipated revenue and expenditures. **Roll Call Vote.** Ayes: Hilferink, Klaassen, Roehrig, Ross, Vandenbossche, Bryson, Hendrick. Nays: None. Motion Carried.

Resolution 016-2023 – Fund Transfer General Fund to Cemetery Fund

Commissioner Ross stated the resolution was needed to make these funds whole.

Motion by Commissioner Bryson, seconded by Commissioner Klaassen, to approve Resolution 016-2023, the Fund Transfer from General Fund to Cemetery Fund as stated in the Amended 2022/2023 Budget in the amount of \$16,000. **Roll Call Vote.** Ayes: Klaassen, Roehrig, Ross, Vandenbossche, Bryson, Hendrick, Hilferink. Nays: None. Motion Carried.

Resolution 017-2023 – Fund Transfer General Fund to Water Sewer Fund

Motion by Commissioner Bryson, seconded by Commissioner Ross, to approve Resolution 017-2023, the Fund Transfer from General Fund to Water/Sewer Fund as stated in the Amended 2022/2023 Budget in the amount of \$4,000. **Roll Call Vote.** Ayes: Roehrig, Ross, Vandenbossche, Bryson, Hendrick, Hilferink, Klaassen. Nays: None. Motion Carried.

Resolution 018-2023 – Fund Transfer General Fund to Water Sewer Fund

Commissioner Ross stated the resolution for fund transfers was for hydrant usage and the previous resolution was for metered water usage for City buildings.

Motion by Commissioner Bryson, seconded by Commissioner Klaassen, to approve Resolution 018-2023, the Fund Transfer from General Fund to Water/Sewer Fund as stated in the Amended 2022/2023 Budget in the amount of \$10,000. **Roll Call Vote.** Ayes: Ross, Vandenbossche, Bryson, Hendrick, Hilferink, Klaassen, Roehrig. Nays: None. Motion Carried.

Resolution 019-2023 – Fund Transfer General Fund to Local Street Fund

Motion by Commissioner Hendrick, seconded by Commissioner Klaassen, to approve Resolution 019-2023 the Fund transfer from General Fund to Local Street Fund as stated in the Amended 2022/23 Budget in the amount of \$3,175. **Roll Call Vote.** Ayes: Bryson, Hendrick, Hilferink, Klaassen, Roehrig, Ross, Vandenbossche. Nays: None. Motion Carried.

Resolution 020-2023 – Fund Transfer General Fund to Major Street Fund

Motion by Commissioner Ross, seconded by Commissioner Klaassen, to approve Resolution 020-2023 the Fund transfer from General Fund to Major Street Fund as stated in the Amended 2022/23 Budget in the amount of \$3,175 for crack sealant. **Roll Call Vote.** Ayes: Hendrick, Hilferink, Klaassen, Roehrig, Ross, Vandenbossche, Bryson. Nays: None. Motion Carried.

Approval of 2023 Tax Rate

Commissioner Hilferink inquired about the total 2022 taxable properties was. City Manager Adkins stated he did not have the hard figures, but there was no change in millage rate.

Motion by Commissioner Bryson, seconded by Commissioner Ross, to approve the 2023 Tax rate as prepared and presented. **Roll Call Vote.** Ayes: Hilferink, Klaassen, Roehrig, Ross, Vandenbossche, Bryson Hendrick. Motion Carried.

NEW BUSINESS

Bridge to Bay Trail Update

Sheri Faust from the Regional Trails Board spoke on the Bridge to Bay Trail update and provided handouts and a large infographic and map. She stated the proposed plan was approved in August of 2020 and work has been done so far. She also stated the project is fully funded and working towards completion. Ms. Faust stated there were a combo of treatments to provide people access to downtown and the old trail system helped shape the project. She also stated the budget was much less than projected and it was moving to the final engineer phase.

Commissioner Hendrick stated the project was much needed and the Commission never decided or approved the road diet and that was still under discussion. She also stated that the project needed to be aware of placing signs in peoples yards and they needed to be efficient in their number and locations. Commissioner Hendrick also stated this would resolve the crosswalks as well. Ms. Faust stated the signs would be consolidated and simpler to make sure there is uniformity across the region.

City Manager Adkins stated the DPW Superintendent was in the process of a trail condition assessment as well as a street sign assessment to decrease and simplify the signage across the City. He also stated an MDOT meeting was scheduled for July to discuss the crosswalks on S Parker as well as the road diet and that there would be a Commission and Community discussion on the road diet to receive input.

Commissioner Hendrick urged residents to voice their concerns over the road diet when those discussions started.

Commissioner Ross stated he forwarded information from MDOT regarding the crosswalks to City Manager Adkins and stated the crosswalks did not meet MDOT standards so the buttons and lights were removed. Commissioner Hendrick stated the buttons and lights were only removed from the crosswalks on S Parker.

Commissioner Ross stated the road diet was planned from Chartier to West Boulevard and it was already approved from Broadway to West Boulevard for a road diet. Commissioner Hendrick stated that plan had already been changed and removed due to a safety issue. City Manager Adkins stated he would get an update on the road diet during the July meeting with MDOT.

Mayor Vandenbossche stated the complimentary services provided for the project were appreciated.

Roof Replacement – Beach Bathrooms

City Manager Adkins spoke on the quotes for roof replacement and DPW Superintendent Schmidt's recommendation of St. Clair Roofing.

Commissioner Hendrick thanked City Manager Adkins and DPW Superintendent Schmidt for getting the quotes on the replacement as the roof was in bad shape. Commissioner Ross inquired if the quote included replacing the soffit as that was bad as well. City Manager Adkins stated it included all parts of the roof and those it did not include, the DPW was going to repair/replace.

Motion by Commissioner Hendrick, seconded by Commissioner Ross, to accept the proposal from St. Clair Roofing in the amount of \$7,000 for the roof replacement at the Beach Bathhouses as recommended. **Roll Call Vote.** Ayes: Klaassen, Roehrig, Ross, Vandenbossche, Bryson, Hendrick, Hilferink. Nays: None. Motion Carried.

Appointment of SEMCOG Delegate and Alternate

City Manager Adkins stated he was contacted by SEMCOG and they stated the City has not had delegates in some time and asked for consideration in the recommendation of Mayor Vandenbossche as the delegate and himself as the alternate. He stated it is common in most municipalities for the Mayor to be the delegate and the City Manager to be the alternate.

Motion by Commissioner Ross, seconded by Commissioner Hendrick, to appoint Mayor Vandenbossche as Member Delegate and City Manager Adkins as Alternate Member Delegate to SEMCOG. **Roll Call Vote.** Ayes: Roehrig, Ross, Vandenbossche, Bryson, Hendrick, Hilferink, Klaassen. Nays: None.

Cancellation of July 6, 2023 City Commission Meeting

Motion by Commissioner Hendrick, seconded by Commissioner Klaassen, to cancel the July 6, 2023 City Commission Meeting. **Roll Call Vote.** Ayes: Ross, Vandenbossche, Bryson, Hendrick, Hilferink, Klaassen, Roehrig. Motion Carried.

ADMINISTRATIVE REPORTS

City Attorney Report

City Attorney Davis stated he had nothing to report. Commissioner Hendrick inquired as to an update on UHY report. City Attorney Davis stated the Commission would be provided something soon.

City Manager Report

City Manager Adkins stated he has a meeting scheduled with East China School District Superintendent regarding the Washington Life Center property. He also stated the Master Plan update kicked off and there would be a community participation survey coming soon and asked citizens to please participate.

Mayor Vandenbossche inquired if equipment had been ordered for the Tot-Lot from the T-Mobile grant award. City Manager Adkins stated the money was received and things were starting to get ordered. Commissioner Hendrick inquired if the Commission would have input on what was going in there and also at the Marina project. City Manager Adkins stated there would be pieces coming to the Commission for their input.

City Manager Adkins stated he was working with DPW Superintendent Schmidt and Police Chief Heaslip on an ordinance amendment regarding the transient docking at the Marina project as well as signage for the docks.

City Manager Adkins stated the demolition at 135 N. 6th Street has yet to be completed and the deadline that was set by the Commission has passed. He stated the property owner will be sent a certified letter stating he had 10 days to complete the work or the City would take action and he would be sent a bill for the completion of the work.

COMMISSIONER PRIVILEGE/LIAISON REPORTS

Commissioner Klaassen stated the Planning Commission was moving along with the Master Plan update.

Commissioner Ross congratulated the Marine City Seniors on graduating and that it was Summer for all other students. He also wished an exchange student well and urged people to try hosting an exchange student in the future as it is a great experience.

Commissioner Roehrig provided an update from the Zoning Board of Appeals and the request for the apartments for height, length and number of rooms was denied 3 to 2 and the other request was approved. She also wished everyone a safe and happy 4th of July.

Commissioner Hendrick wished everyone a safe and happy 4th of July and wanted everyone to watch out for kids during the Summer and to have a safe Summer.

Mayor Vandebossche wished everyone a happy 4th of July and that East China School District was offering a free breakfast and lunch program throughout the Summer and to check their website for details and locations.

ADJOURNMENT

Motion by Commissioner Ross, seconded by Commissioner Klaassen, to adjourn at 7:41 p.m. All Ayes. Motion Carried.

Respectfully submitted,

Jason A. Bell
Interim City Clerk



MARINE CITY FIRE DEPARTMENT

200 South Parker Street • Marine City, Michigan 48039
810-765-8840 • Fax 810-765-5199

June 1st, 2023

The following is a list of the Marine City Area Fire Authority runs for the month of May-23

Medical Emergency	38	Service Call / Mutual Aid	10
M V Accidents	5	Gas Leak	1
Illegal Burn	2		
Fire Alarm	6		
Camper Fire	1		
Wires Down	3		

Total monthly runs 66

The following is a list of runs by the Township or City they occurred:

<u>City of Marine City</u>		<u>Cottrellville Twp</u>	
Medical Emergency	22	Medical Emergency	11
M V Accident	1	Illegal Burn	1
Fire Alarm	4	M V Accident	1
Power Line Down	2		
Illegal Burn	1		

<u>East China Twp</u>		<u>China Twp</u>	
Medical Emergency	3	Medical Emergency	2
Smoke Alarm	2	M V Accidents	2
Power Line Down	1	Camper Fire	1
M V Accident	2		

Total Monthly Runs 66

Joseph A. Siankster

Fire Chief

MCAFA

PLEASE HELP PREVENT FIRES



Office of City Clerk

TO: Scott Adkins, City Manger
FROM: Jason Bell
DATE: July 5, 2023
SUBJECT: June Activity Report

- Received 2 Freedom of Information Act Requests
- Processed 2 Freedom of Information Act Requests
- 0 full burials, 3 urn burials at Woodlawn Cemetery
- Prepared Minutes for Board Meetings
- Made updates to City Website
- Deputy Clerk resubmitted for Spark Grants for Tot Lot and Beach Bathrooms & SCCCf Tot Lot Grant Request
- Deputy Clerk updated Code Enforcement Form Letters, Assessing website data and blight procedure



Marine City Police Department

James D. Heaslip
Chief of Police

375 S. Parker Street ● Marine City, Michigan 48039
(810) 765-4040 ● Fax (810) 765-4135

July 5, 2023

City Manager Adkins:

During the month of June 2023, Marine City Police Department responded to 357 complaints. An activity log detailing incident type, report date, and the Officer that handled the complaint is attached.

The following is a summary of meetings and calls I have responded to for the month:

- Issued 37 Lexipol Policy Updates
- Issued 24 Lexipol Daily Training Bulletins
- Coordinated Patrol Car Outfitting and Graphics
- Attended Code Enforcement Meeting with City Office Staff
- Attended meeting with Border Patrol Supervisory Agent in Charge
- Attended Stonegarden Grant Fund Meetings
- Attended Maritime Days Meeting
- Attended Meeting regarding Lester Family Cemetery Issues
- Interview Process and Background for Potential New Hire
- Finalized Completion of Annual Report

Sincerely,

James D. Heaslip
Chief of Police

“Police EXCELLENCE through COMMUNITY Partnership”
Marine City is an Equal Opportunity Provider

#	DATE/TIME	INCIDENT #	LOCATION	OFFICER	OFFENSE
1	06/01/2023 12:00 AM	230001200	CHARTIER RD&S PARKER ST	MAREDMAND	L3590 - Traffic Stop - MA
2	06/01/2023 09:21 AM	230001201	900 CEDAR ST	MAKENYONT	C3299 - Welfare Check
3	06/01/2023 11:38 AM	230001202	S PARKER ST&CHARTIER RD	MAMARTINELLIC	C4041 - Speeding Citation
4	06/01/2023 11:55 AM	230001203	S MARKET ST&E SAINT CLAIR ST	MAMARTINELLIC	C4041 - Speeding Citation
5	06/01/2023 12:53 PM	230001204	CHARTIER RD&S PARKER ST	MAMARTINELLIC	C4041 - Speeding Citation
6	06/01/2023 01:24 PM	230001205	428 S WILLIAM ST	MABELLJ	L3520 - Pistol Sales Record - MA
7	06/01/2023 02:50 PM	230001206	312 S BELLE RIVER AVE	MAMARTINELLIC	C3324 - Suspicious Circumstances
8	06/01/2023 06:47 PM	230001207	2088 S PARKER ST	MAMARTINELLIC	C3902 - Burglary Alarm
9	06/01/2023 09:28 PM	230001208	401 DELINA ST	MADEKUNM	C3324 - Suspicious Circumstances
10	06/01/2023 10:16 PM	230001209	375 S PARKER ST	MADEKUNM	C3804 - Animal Complaint
11	06/02/2023 08:10 AM	230001210	1085 WARD ST	MAKENYONT	C4802 - Nicotine Violation - Civil Infraction
12	06/02/2023 08:17 AM	230001211	N MARY ST&WESTMINSTER ST	MAMARTINELLIC	L3590 - Traffic Stop - MA
13	06/02/2023 08:36 AM	230001212	N MARY ST&WOODWORTH ST	MAMARTINELLIC	L3590 - Traffic Stop - MA
14	06/02/2023 08:44 AM	230001213	1085 WARD ST	MAVANDERMEULENJ	L3590 - Traffic Stop - MA
15	06/02/2023 08:44 AM	230001214	N MARY ST&WOODWORTH ST	MAMARTINELLIC	C4105 - Equipment Citation
16	06/02/2023 09:05 AM	230001215	N MARY ST&WOODWORTH ST	MAMARTINELLIC	L3590 - Traffic Stop - MA
17	06/02/2023 09:16 AM	230001216	N MARY ST&WOODWORTH ST	MAMARTINELLIC	L3590 - Traffic Stop - MA
18	06/02/2023 09:25 AM	230001217	N MARY ST&HOLLAND ST	MAMARTINELLIC	L3590 - Traffic Stop - MA
19	06/02/2023 09:41 AM	230001218	N MARY ST&HOLLAND ST	MAMARTINELLIC	L3590 - Traffic Stop - MA
20	06/02/2023 09:59 AM	230001219	WOODWORTH ST&N MARY ST	MAMARTINELLIC	C4046 - Disobey Stop Sign Citation
21	06/02/2023 10:21 AM	230001220	MABEL ST&PLEASANT ST	MAMARTINELLIC	L3590 - Traffic Stop - MA
22	06/02/2023 10:58 AM	230001221	DEGURSE AVE&N BELLE RIVER AVE	MAMARTINELLIC	C4105 - Equipment Citation
23	06/02/2023 11:15 AM	230001222	N BELLE RIVER AVE&DEGURSE AVE	MAMARTINELLIC	C4046 - Disobey Stop Sign Citation
24	06/02/2023 11:40 AM	230001223	N BELLE RIVER AVE&DEGURSE AVE	MAMARTINELLIC	L3590 - Traffic Stop - MA
25	06/02/2023 12:03 PM	230001224	GLADYS ST&N BELLE RIVER AVE	MAMARTINELLIC	L3590 - Traffic Stop - MA
26	06/02/2023 12:16 PM	230001225	N BELLE RIVER AVE&FAIRBANKS ST	MAMARTINELLIC	L3590 - Traffic Stop - MA
27	06/02/2023 12:29 PM	230001226	DEGURSE AVE&N BELLE RIVER AVE	MAMARTINELLIC	L3590 - Traffic Stop - MA

#	DATE/TIME	INCIDENT #	LOCATION	OFFICER	OFFENSE
28	06/02/2023 12:30 PM	230001227	1239 S PARKER ST	MAVANDERMEULENJ	C3299 - Welfare Check
29	06/02/2023 01:25 PM	230001228	327 S ELIZABETH ST	MAVANDERMEULENJ	C3804 - Animal Complaint
30	06/02/2023 02:05 PM	230001229	551 MAPLE ST	MAVANDERMEULENJ	C3704 - Traffic Complaint / Abandoned Auto
31	06/02/2023 02:22 PM	230001230	BROADWAY ST&N MARKET ST	MAMARTINELLIC	C2934 - Vehicle Insurance - None / Expired
32	06/02/2023 02:37 PM	230001231	334 S WATER ST	MAKENYONT	C3324 - Suspicious Circumstances
33	06/02/2023 02:49 PM	230001232	S WATER ST&BRIDGE ST	MAMARTINELLIC	C4041 - Speeding Citation
34	06/02/2023 03:12 PM	230001233	CHARTIER RD&S PARKER ST	MAMARTINELLIC	C4041 - Speeding Citation
35	06/03/2023 12:30 AM	230001234	MARINE CITY HWY&MARSH RD	NA	L3592 BOL - MA
36	06/03/2023 11:08 AM	230001235	KING RD&BRUCE ST	MAVANDERMEULENJ	C4041 - Speeding Citation
37	06/03/2023 12:59 PM	230001236	820 ROBERTSON ST	MAVANDERMEULENJ	C3331 - Assist Medical
38	06/04/2023 12:27 AM	230001237	121 BROADWAY ST	MADEKUNM	C3324 - Suspicious Circumstances
39	06/04/2023 12:43 AM	230001238	511 S MAIN ST	MADEKUNM	C2899 - Juvenile - All Other
40	06/04/2023 08:50 AM	230001239	N BELLE RIVER AVE&DEGURSE AVE	MAVANDERMEULENJ	L3590 - Traffic Stop - MA
41	06/04/2023 10:24 AM	230001240	CHARTIER RD&KING RD	MAVANDERMEULENJ	L3590 - Traffic Stop - MA
42	06/04/2023 03:17 PM	230001241	147 S PARKER ST	MAVANDERMEULENJ	C3331 - Assist Medical
43	06/04/2023 04:14 PM	230001242	540 HOLLAND ST	MAVANDERMEULENJ	3898 - Cruelty/Neglect (Other) [38001]
44	06/04/2023 04:49 PM	230001243	218 PLEASANT ST	NA	L3542 Follow Up - MA
45	06/04/2023 07:58 PM	230001244	5719 MARINE CITY HWY	MADEKUNM	C3330 - Assist Other Law Enforcement Agency
46	06/04/2023 08:21 PM	230001245	1215 S BELLE RIVER AVE	MADEKUNM	C3145 - Property Damage Traffic Crash PDA
47	06/04/2023 11:05 PM	230001246	511 S MAIN ST	MADEKUNM	C3312 - Neighborhood Trouble
48	06/05/2023 07:37 AM	230001247	S. PARKER ST/DELINA ST	NA	C3330 - Assist Other Law Enforcement Agency
49	06/05/2023 09:59 AM	230001248	S PARKER ST&WARD ST	MAMARTINELLIC	C3804 - Animal Complaint
50	06/05/2023 11:17 AM	230001249	318 N ELIZABETH ST	MAMARTINELLIC	C3145 - Property Damage Traffic Crash PDA
51	06/05/2023 01:02 PM	230001250	1601 CHARTIER RD	MAKENYONT	L3513 - Property Check - MA
52	06/05/2023 01:42 PM	230001251	6550 KING RD	MAMARTINELLIC	C3324 - Suspicious Circumstances
53	06/05/2023 02:24 PM	230001252	250 S MARKET ST	MAMARTINELLIC	C3324 - Suspicious Circumstances
54	06/05/2023 04:01 PM	230001253	1300 S PARKER ST	MAMARTINELLIC	C3902 - Burglary Alarm

#	DATE/TIME	INCIDENT #	LOCATION	OFFICER	OFFENSE
55	06/05/2023 07:24 PM	230001254	375 S PARKER ST	MADEKUNM	C3355 - Civil Matter - Other
56	06/05/2023 07:35 PM	230001255	375 S PARKER ST	MADEKUNM	C3355 - Civil Matter - Other
57	06/05/2023 08:13 PM	230001256	6764 RIVER RD	MADEKUNM	C3324 - Suspicious Circumstances
58	06/05/2023 09:00 PM	230001257	425 E SAINT CLAIR ST	MADEKUNM	C3324 - Suspicious Circumstances
59	06/05/2023 11:40 PM	230001258	435 N WILLIAM ST	MADEKUNM	C3331 - Assist Medical
60	06/06/2023 04:33 AM	230001259	2034 RIVER RD	MADEKUNM	C3330 - Assist Other Law Enforcement Agency
61	06/06/2023 07:17 AM	230001260	375 S PARKER ST	MABELLJ	L3522 - Records Check - MA
62	06/06/2023 07:23 AM	230001261	329 CHARTIER RD	MAMARTINELLIC	C3804 - Animal Complaint
63	06/06/2023 08:18 AM	230001262	517 WARD ST	MAMARTINELLIC	1313 - Assault/Battery/Simple (Incl Domestic and Police Officer [13001])
64	06/06/2023 09:30 AM	230001263	6373 KING RD	MAKENYONT	C3399 - Miscellaneous All Other
65	06/06/2023 09:32 AM	230001264	375 S PARKER ST	MAMARTINELLIC	C3336 - Assist Citizen
66	06/06/2023 02:20 PM	230001265	142 N 5TH ST	MAMARTINELLIC	C3312 - Neighborhood Trouble
67	06/06/2023 05:23 PM	230001266	407 BROWN ST	MAMARTINELLIC	C3324 - Suspicious Circumstances
68	06/06/2023 06:07 PM	230001267	1323 MILITARY ST	NA	L3501 - Dispatch Error - MA
69	06/06/2023 07:46 PM	230001268	407 BROWN ST	MADEKUNM	C3324 - Suspicious Circumstances
70	06/06/2023 08:17 PM	230001269	517 WARD ST	MADEKUNM	C3355 - Civil Matter - Other
71	06/07/2023 05:17 AM	230001270	6800 KING RD	MADEKUNM	C3299 - Welfare Check
72	06/07/2023 09:41 AM	230001271	375 S PARKER ST	MABELLJ	C3381 - Sex Offender Registration - SOR
73	06/07/2023 10:31 AM	230001272	318 N ELIZABETH ST	MAVANDERMEULENJ	C3704 - Traffic Complaint / Abandoned Auto
74	06/07/2023 11:30 AM	230001273	MARINE CITY HWY&MARSH RD	MAVANDERMEULENJ	C4048 - Improper Passing Citation
75	06/07/2023 02:07 PM	230001274	1085 WARD ST	MAKENYONT	C2899 - Juvenile - All Other
76	06/07/2023 03:10 PM	230001275	1085 WARD ST	MAKENYONT	1313 - Assault/Battery/Simple (Incl Domestic and Police Officer [13001])
77	06/07/2023 03:24 PM	230001276	517 WARD ST	MAVANDERMEULENJ	C3334 - Assist Other Govt Agency
78	06/07/2023 04:03 PM	230001277	1085 WARD ST	MABELLJ	L3505 - Opened in Error - MA
79	06/08/2023 08:39 AM	230001278	355 S MAIN ST	MAVANDERMEULENJ	C3804 - Animal Complaint
80	06/08/2023 08:57 AM	230001279	375 S PARKER ST	MABELLJ	C3336 - Assist Citizen
81	06/08/2023 10:23 AM	230001280	375 S PARKER ST	MABELLJ	C3381 - Sex Offender Registration - SOR

#	DATE/TIME	INCIDENT #	LOCATION	OFFICER	OFFENSE
82	06/08/2023 04:05 PM	230001281	218 PLEASANT ST	NA	L3542 Follow Up - MA
83	06/08/2023 10:34 PM	230001282	1229 S PARKER ST	MAREDMAND	C3324 - Suspicious Circumstances
84	06/09/2023 11:15 AM	230001283	S WATER ST&BRIDGE ST	MAMARTINELLIC	L3590 - Traffic Stop - MA
85	06/09/2023 12:15 PM	230001284	S MARKET ST&E SAINT CLAIR ST	MAMARTINELLIC	L3590 - Traffic Stop - MA
86	06/09/2023 12:33 PM	230001285	CHARTIER RD&S PARKER ST	MAMARTINELLIC	L3590 - Traffic Stop - MA
87	06/09/2023 12:38 PM	230001286	2088 S PARKER ST	MAMARTINELLIC	1313 - Assault/ Battery/Simple (Incl Domestic and Police Officer [13001]
88	06/09/2023 05:02 PM	230001287	S WATER ST&JEFFERSON ST	MAMARTINELLIC	L3590 - Traffic Stop - MA
89	06/09/2023 05:38 PM	230001288	428 PEARL ST	MAMARTINELLIC	C3299 - Welfare Check
90	06/10/2023 09:37 AM	230001289	BROADWAY ST&N WILLIAM ST	MAMARTINELLIC	L3590 - Traffic Stop - MA
91	06/10/2023 10:00 AM	230001290	N MAIN ST&WOODWORTH ST	MAMARTINELLIC	L3590 - Traffic Stop - MA
92	06/10/2023 12:51 PM	230001291	N BELLE RIVER AVE&DEGURSE AVE	MAMARTINELLIC	L3590 - Traffic Stop - MA
93	06/10/2023 01:23 PM	230001292	BROADWAY ST&N MAIN ST	MAMARTINELLIC	L3590 - Traffic Stop - MA
94	06/10/2023 01:31 PM	230001293	WASHINGTON ST&S WILLIAM ST	MAMARTINELLIC	L3590 - Traffic Stop - MA
95	06/10/2023 02:17 PM	230001294	S WATER ST&UNION ST	MAMARTINELLIC	L3590 - Traffic Stop - MA
96	06/10/2023 04:48 PM	230001295	S WATER ST&E SAINT CLAIR ST	MAMARTINELLIC	L3590 - Traffic Stop - MA
97	06/10/2023 06:24 PM	230001296	801 SCOTT ST	MAMARTINELLIC	C3310 - Family Trouble
98	06/10/2023 08:52 PM	230001297	165 N 5TH ST	MAREDMAND	C3336 - Assist Citizen
99	06/10/2023 09:24 PM	230001298	MARINE CITY BEACH	MAREDMAND	L3550 - Fireworks Complaint - MA
100	06/10/2023 09:56 PM	230001299	553 WOODWORTH ST	MAREDMAND	L3510 - Noise Complaint - MA
101	06/10/2023 09:59 PM	230001300	6800 KING RD	MAREDMAND	C3355 - Civil Matter - Other
102	06/10/2023 10:46 PM	230001301	243 DELINA ST	MAREDMAND	L3510 - Noise Complaint - MA
103	06/10/2023 11:20 PM	230001302	551 WOODWORTH ST	MAREDMAND	C3326 - Suspicious Vehicles
104	06/11/2023 09:58 AM	230001303	BROADWAY ST&N WILLIAM ST	MAMARTINELLIC	C4041 - Speeding Citation
105	06/11/2023 10:37 AM	230001304	BROADWAY ST&S MAIN ST	MAMARTINELLIC	L3590 - Traffic Stop - MA
106	06/11/2023 10:53 AM	230001305	S MAIN ST&BROADWAY ST	MAMARTINELLIC	L3590 - Traffic Stop - MA
107	06/11/2023 11:22 AM	230001306	452 S MAIN ST	MAMARTINELLIC	C3324 - Suspicious Circumstances
108	06/11/2023 12:24 PM	230001307	S WATER ST&BRIDGE ST	MAMARTINELLIC	L3590 - Traffic Stop - MA
109	06/11/2023 12:51 PM	230001308	S MAIN ST&E SAINT CLAIR ST	MAMARTINELLIC	L3590 - Traffic Stop - MA
110	06/11/2023 02:11 PM	230001309	JEFFERSON ST&S WATER ST	MAMARTINELLIC	L3590 - Traffic Stop - MA

#	DATE/TIME	INCIDENT #	LOCATION	OFFICER	OFFENSE
111	06/11/2023 02:19 PM	230001310	6550 KING RD	MAMARTINELLIC	C3208 - Death Investigation - Cause Unknown
112	06/12/2023 08:29 AM	230001311	536 S PARKER ST	MAVANDERMEULENJ	3077 - Retail Fraud, Misrepresentation 3rd Degree [30001]
113	06/12/2023 08:39 AM	230001312	505 UNION ST	MABELLJ	L3520 - Pistol Sales Record - MA
114	06/12/2023 08:39 AM	230001313	165 BRUCE ST	MABELLJ	L3520 - Pistol Sales Record - MA
115	06/12/2023 08:39 AM	230001314	126 JEFFERSON ST	MABELLJ	L3520 - Pistol Sales Record - MA
116	06/12/2023 09:40 AM	230001315	6730 RIVER RD	MAVANDERMEULENJ	C3324 - Suspicious Circumstances
117	06/12/2023 01:29 PM	230001316	516 S PARKER ST	NA	L3542 Follow Up - MA
118	06/12/2023 05:41 PM	230001317	2026 S PARKER ST	MAVANDERMEULENJ	C3902 - Burglary Alarm
119	06/12/2023 10:15 PM	230001318	406 BROWN ST	MAREDMAND	C3310 - Family Trouble
120	06/13/2023 03:43 AM	230001319	605 S PARKER ST	MAREDMAND	C3902 - Burglary Alarm
121	06/13/2023 08:19 AM	230001320	100 WASHINGTON ST	MAVANDERMEULENJ	C3728 - Traffic Complaint / Parking Complaint
122	06/13/2023 08:38 AM	230001321	6551 RIVER RD	MAVANDERMEULENJ	C3145 - Property Damage Traffic Crash PDA
123	06/13/2023 09:10 AM	230001322	375 S PARKER ST	MABELLJ	C3330 - Assist Other Law Enforcement Agency
124	06/13/2023 10:49 AM	230001323	6661 RIVER RD	MAVANDERMEULENJ	C3145 - Property Damage Traffic Crash PDA
125	06/13/2023 12:38 PM	230001324	6764 RIVER RD	NA	L3592 BOL - MA
126	06/13/2023 02:38 PM	230001325	159 CHARTIER RD	NA	L3598 - General Assistance - Specify - MA
127	06/13/2023 08:56 PM	230001326	233 S MARY ST	MAREDMAND	C3336 - Assist Citizen
128	06/13/2023 11:30 PM	230001327	218 PLEASANT ST	MAREDMAND	C3336 - Assist Citizen
129	06/14/2023 09:17 AM	230001328	375 S PARKER ST	MABELLJ	L3520 - Pistol Sales Record - MA
130	06/14/2023 11:37 AM	230001329	N MARY ST&WOODWORTH ST	MAMARTINELLIC	C3728 - Traffic Complaint / Parking Complaint
131	06/14/2023 12:48 PM	230001330	536 S PARKER ST	MAMARTINELLIC	C3324 - Suspicious Circumstances
132	06/14/2023 03:18 PM	230001331	S MAIN ST&BRIDGE ST	MAMARTINELLIC	L3590 - Traffic Stop - MA
133	06/14/2023 04:03 PM	230001332	375 S PARKER ST	NA	L3542 Follow Up - MA
134	06/14/2023 04:56 PM	230001333	S WATER ST&E SAINT CLAIR ST	MAMARTINELLIC	L3590 - Traffic Stop - MA
135	06/15/2023 01:32 AM	230001334	536 S PARKER ST	MAREDMAND	C3324 - Suspicious Circumstances
136	06/15/2023 07:32 AM	230001335	BROADWAY ST&N ELIZABETH ST	MAMARTINELLIC	L3590 - Traffic Stop - MA

#	DATE/TIME	INCIDENT #	LOCATION	OFFICER	OFFENSE
137	06/15/2023 07:50 AM	230001336	1085 WARD ST	MAMARTINELLIC	C3332 - Assist Fire Department
138	06/15/2023 08:24 AM	230001337	452 S MAIN ST	MAMARTINELLIC	C3326 - Suspicious Vehicles
139	06/15/2023 09:02 AM	230001338	375 S PARKER ST	MABELLJ	L3522 - Records Check - MA
140	06/15/2023 09:09 AM	230001339	6005 KING RD	MAMARTINELLIC	C3324 - Suspicious Circumstances
141	06/15/2023 09:25 AM	230001340	763 S WATER ST	MAMARTINELLIC	C3333 - Assist Motorist
142	06/15/2023 09:57 AM	230001341	660 S WATER ST	MAMARTINELLIC	C3728 - Traffic Complaint / Parking Complaint
143	06/15/2023 10:12 AM	230001342	100 N WATER ST	MAMARTINELLIC	2903 - Damage to Property - Public Property - MDOP [29000]
144	06/15/2023 12:05 PM	230001343	141 S WILLIAM ST	MAMARTINELLIC	C3324 - Suspicious Circumstances
145	06/15/2023 12:10 PM	230001344	100 N WATER ST	MAMARTINELLIC	C3318 - Found Property
146	06/15/2023 12:49 PM	230001345	6005 KING RD	NA	L3542 Follow Up - MA
147	06/15/2023 01:13 PM	230001346	375 S PARKER ST	MABELLJ	L3522 - Records Check - MA
148	06/15/2023 02:03 PM	230001347	100 N WATER ST	MAMARTINELLIC	2903 - Damage to Property - Public Property - MDOP [29000]
149	06/15/2023 03:03 PM	230001348	MARINE CITY HWY&KING RD	MAKENYONT	C3324 - Suspicious Circumstances
150	06/16/2023 08:45 AM	230001349	N BELLE RIVER AVE&DEGURSE AVE	MAMARTINELLIC	C4041 - Speeding Citation
151	06/16/2023 08:58 AM	230001350	BROADWAY ST&S MARY ST	MAMARTINELLIC	C4041 - Speeding Citation
152	06/16/2023 09:15 AM	230001351	N BELLE RIVER AVE&DEGURSE AVE	MAMARTINELLIC	L3590 - Traffic Stop - MA
153	06/16/2023 09:25 AM	230001352	BROADWAY ST&S MARY ST	MAMARTINELLIC	C2931 - DWLS OPS License Suspended / Revoked
154	06/16/2023 10:03 AM	230001353	DEGURSE AVE&N BELLE RIVER AVE	MAMARTINELLIC	L3590 - Traffic Stop - MA
155	06/16/2023 10:25 AM	230001354	S WILLIAM ST&BROADWAY ST	MAMARTINELLIC	L3590 - Traffic Stop - MA
156	06/16/2023 10:42 AM	230001355	DEGURSE AVE&KING RD	MAMARTINELLIC	L3590 - Traffic Stop - MA
157	06/16/2023 11:36 AM	230001356	BROADWAY ST&N ELIZABETH ST	MAMARTINELLIC	L3590 - Traffic Stop - MA
158	06/16/2023 11:50 AM	230001357	BROADWAY ST&N ELIZABETH ST	MAMARTINELLIC	L3590 - Traffic Stop - MA
159	06/16/2023 12:15 PM	230001358	N MAIN ST&WOODWORTH ST	MAMARTINELLIC	C4313 - Veh Reg Impr/Expired Citation
160	06/16/2023 12:26 PM	230001359	BROADWAY ST&N ELIZABETH ST	MAMARTINELLIC	L3590 - Traffic Stop - MA
161	06/16/2023 12:35 PM	230001360	6040 KING RD	MAVANDERMEULENJ	3078 - Retail Fraud, Theft 3rd Degree [30002]
162	06/16/2023 12:38 PM	230001361	N ELIZABETH ST&HOLLAND ST	MAMARTINELLIC	L3590 - Traffic Stop - MA

#	DATE/TIME	INCIDENT #	LOCATION	OFFICER	OFFENSE
163	06/16/2023 12:59 PM	230001362	N MARY ST&BROADWAY ST	MAMARTINELLIC	L3590 - Traffic Stop - MA
164	06/16/2023 01:47 PM	230001363	S WATER ST&WASHINGTON ST	MAMARTINELLIC	L3590 - Traffic Stop - MA
165	06/16/2023 01:54 PM	230001364	CHARTIER RD&S PARKER ST	MAMARTINELLIC	L3590 - Traffic Stop - MA
166	06/16/2023 03:25 PM	230001365	PLANK RD&KING RD	MAMARTINELLIC	L3590 - Traffic Stop - MA
167	06/16/2023 03:39 PM	230001366	S PARKER ST&WEST BLVD	MAMARTINELLIC	C4041 - Speeding Citation
168	06/16/2023 03:47 PM	230001367	KING RD&WARD ST	MAVANDERMEULENJ	L3590 - Traffic Stop - MA
169	06/16/2023 04:06 PM	230001368	FAIRBANKS ST&N 2ND ST	MAMARTINELLIC	L3590 - Traffic Stop - MA
170	06/16/2023 04:25 PM	230001369	317 N 2ND ST	MAVANDERMEULENJ	C3704 - Traffic Complaint / Abandoned Auto
171	06/16/2023 04:52 PM	230001370	FAIRBANKS ST&N 2ND ST	MAVANDERMEULENJ	C4041 - Speeding Citation
172	06/16/2023 07:12 PM	230001371	1229 S PARKER ST	MADEKUNM	L3590 - Traffic Stop - MA
173	06/16/2023 07:20 PM	230001372	1296 S PARKER ST	MADEKUNM	L3590 - Traffic Stop - MA
174	06/16/2023 07:23 PM	230001373	S PARKER ST&ALGER ST	MADEKUNM	L3590 - Traffic Stop - MA
175	06/16/2023 07:36 PM	230001374	1295 S PARKER ST	MADEKUNM	L3590 - Traffic Stop - MA
176	06/16/2023 07:47 PM	230001375	CHARTIER RD&S PARKER ST	MADEKUNM	L3590 - Traffic Stop - MA
177	06/16/2023 09:31 PM	230001376	452 S MAIN ST	MADEKUNM	L3550 - Fireworks Complaint - MA
178	06/16/2023 10:30 PM	230001377	S PARKER ST&ROBERTSON ST	MAJONESJ	L3590 - Traffic Stop - MA
179	06/16/2023 10:41 PM	230001378	CHARTIER RD&S PARKER ST	MAJONESJ	L3590 - Traffic Stop - MA
180	06/17/2023 11:29 AM	230001379	609 WARD ST	MAVANDERMEULENJ	C3170 - Private Property Traffic Crash
181	06/17/2023 12:04 PM	230001380	S PARKER ST&THOMPSON DR	NA	L3592 BOL - MA
182	06/17/2023 12:56 PM	230001381	750 CARROLL ST	MAVANDERMEULENJ	C3324 - Suspicious Circumstances
183	06/17/2023 03:59 PM	230001382	6764 RIVER RD	MAKELLYP	C4205 - Handicapped Parking Citation
184	06/17/2023 04:29 PM	230001383	S PARKER ST&CHARTIER RD	MAKELLYP	C2933 - Vehicle Registration - Improper / Expired
185	06/17/2023 05:29 PM	230001384	KING RD&WARD ST	MAKELLYP	C4041 - Speeding Citation
186	06/17/2023 07:15 PM	230001385	1229 S PARKER ST	MADEKUNM	L3590 - Traffic Stop - MA
187	06/17/2023 07:22 PM	230001386	1295 S PARKER ST	MADEKUNM	L3590 - Traffic Stop - MA
188	06/17/2023 07:44 PM	230001387	1295 S PARKER ST	MADEKUNM	L3590 - Traffic Stop - MA
189	06/17/2023 09:10 PM	230001388	553 WOODWORTH ST	MADEKUNM	C3324 - Suspicious Circumstances
190	06/17/2023 10:17 PM	230001389	373 WOODWORTH ST	MADEKUNM	C3324 - Suspicious Circumstances
191	06/18/2023 12:07 AM	230001390	373 WOODWORTH ST	NA	L3542 Follow Up - MA

#	DATE/TIME	INCIDENT #	LOCATION	OFFICER	OFFENSE
192	06/18/2023 12:36 AM	230001391	S WILLIAM ST&BROADWAY ST	MADEKUNM	L3590 - Traffic Stop - MA
193	06/18/2023 01:28 AM	230001392	S PARKER ST&BRUCE ST	MAKELLYP	L3590 - Traffic Stop - MA
194	06/18/2023 01:44 AM	230001393	705 LOWELL ST	MAKELLYP	C3250 - Mental Health Call
195	06/18/2023 09:29 AM	230001394	200 S PARKER ST	MAVANDERMEULENJ	C4041 - Speeding Citation
196	06/18/2023 11:58 AM	230001395	WEST BLVD&N 4TH ST	MAVANDERMEULENJ	L3590 - Traffic Stop - MA
197	06/18/2023 04:25 PM	230001396	WEST&FOURTH	MAKELLYP	L3590 - Traffic Stop - MA
198	06/18/2023 04:12 PM	230001397	5639 SAINT CLAIR HWY	MAVANDERMEULENJ	C3330 - Assist Other Law Enforcement Agency
199	06/18/2023 04:55 PM	230001398	W SAINT CLAIR ST&S PARKER ST	MAKELLYP	C3720 - Traffic Complaint / Motorcycle Complaint
200	06/18/2023 06:11 PM	230001399	DÉGURSE AVE&RIVER VALLEY DR	MAKELLYP	C4041 - Speeding Citation
201	06/18/2023 09:32 PM	230001400	KING RD&PUTTYGUT RD	NA	L3592 BOL - MA
202	06/18/2023 10:27 PM	230001401	240 S WATER ST	MADEKUNM	C3336 - Assist Citizen
203	06/18/2023 11:34 PM	230001402	KING RD&WEST BLVD	MAKELLYP	C4041 - Speeding Citation
204	06/18/2023 11:58 PM	230001403	373 WOODWORTH ST	MAKELLYP	C3310 - Family Trouble
205	06/19/2023 07:30 AM	230001404	375 S PARKER ST	MABELLJ	L3522 - Records Check - MA
206	06/19/2023 09:25 AM	230001405	BRUCE ST&KING RD	MAMARTINELLIC	C3804 - Animal Complaint
207	06/19/2023 09:51 AM	230001406	BROADWAY ST&S MAIN ST	MAMARTINELLIC	L3590 - Traffic Stop - MA
208	06/19/2023 11:31 AM	230001407	BROADWAY ST&S MAIN ST	MAMARTINELLIC	L3590 - Traffic Stop - MA
209	06/19/2023 11:45 AM	230001408	WESTMINSTER ST&N ELIZABETH ST	MAMARTINELLIC	L3590 - Traffic Stop - MA
210	06/19/2023 11:56 AM	230001409	N MAIN ST&WOODWORTH ST	MAMARTINELLIC	C2934 - Vehicle Insurance None / Expired
211	06/19/2023 12:40 PM	230001410	RIVER RD&SHORTCUT RD	MAMARTINELLIC	L3590 - Traffic Stop - MA
212	06/19/2023 02:22 PM	230001411	515 S PARKER ST	MAKENYONT	2901 - Damage to Property - Business Property - MDOP [29000]
213	06/19/2023 03:14 PM	230001412	KING RD&WEST BLVD	MAMARTINELLIC	L3590 - Traffic Stop - MA
214	06/19/2023 03:26 PM	230001413	CHANNEL DR&MICHIGAN DR	MAMARTINELLIC	C4041 - Speeding Citation
215	06/19/2023 03:39 PM	230001414	WEST BLVD&KING RD	MAMARTINELLIC	C4041 - Speeding Citation
216	06/19/2023 03:37 PM	230001415	211 MICHIGAN DR	MAMARTINELLIC	C3728 - Traffic Complaint / Parking Complaint
217	06/19/2023 05:00 PM	230001416	234 S MARKET ST	MAMARTINELLIC	C3332 - Assist Fire Department
218	06/20/2023 08:55 AM	230001417	BROADWAY ST&N ELIZABETH ST	MAMARTINELLIC	L3590 - Traffic Stop - MA

#	DATE/TIME	INCIDENT #	LOCATION	OFFICER	OFFENSE
219	06/20/2023 09:49 AM	230001418	N MAIN ST&WOODWORTH ST	MAMARTINELLIC	L3590 - Traffic Stop - MA
220	06/20/2023 10:03 AM	230001419	BROADWAY ST&N ELIZABETH ST	MAMARTINELLIC	C4041 - Speeding Citation
221	06/20/2023 12:29 PM	230001420	DEGURSE AVE&N BELLE RIVER AVE	MAMARTINELLIC	L3590 - Traffic Stop - MA
222	06/20/2023 12:47 PM	230001421	BROADWAY ST&S MARY ST	MAMARTINELLIC	L3590 - Traffic Stop - MA
223	06/20/2023 02:41 PM	230001422	375 S PARKER ST	MABELLJ	L3522 - Records Check - MA
224	06/20/2023 02:44 PM	230001423	341 S WATER ST	MAKENYONT	C3318 - Found Property
225	06/20/2023 02:58 PM	230001424	S PARKER ST&WEST BLVD	MAMARTINELLIC	L3590 - Traffic Stop - MA
226	06/20/2023 05:01 PM	230001425	S WATER ST&WASHINGTON ST	MAMARTINELLIC	L3590 - Traffic Stop - MA
227	06/20/2023 05:33 PM	230001426	200 S WATER ST	MAKENYONT	2302 - Larceny - Purse Snatching - No Force [23002]
228	06/20/2023 11:20 PM	230001427	514 S WATER ST	MADEKUNM	C3324 - Suspicious Circumstances
229	06/21/2023 03:47 AM	230001428	234 DEGURSE AVE	MADEKUNM	C3331 - Assist Medical
230	06/21/2023 04:03 AM	230001429	435 N WILLIAM ST	MADEKUNM	C3331 - Assist Medical
231	06/21/2023 07:19 AM	230001430	2100 PLANK RD	MAKELLYP	C3902 - Burglary Alarm
232	06/21/2023 08:09 AM	230001431	KING RD&WARD ST	MAKELLYP	C2931 - DWLS OPS License Suspended / Revoked
233	06/21/2023 09:39 AM	230001432	1859 S PARKER ST	MAKELLYP	C3312 - Neighborhood Trouble
234	06/21/2023 09:46 AM	230001433	375 S PARKER ST	MABELLJ	L3521 - Pistol Purchase Permit - MA
235	06/21/2023 09:51 AM	230001434	211 MICHIGAN DR	MABELLJ	L3520 - Pistol Sales Record - MA
236	06/21/2023 10:03 AM	230001435	102 PEARL ST	MAKELLYP	C3318 - Found Property
237	06/21/2023 10:39 AM	230001436	S MAIN ST&BROADWAY ST	MAHEASLIPJ	C4299 - Other Parking Citations
238	06/21/2023 03:31 PM	230001437	N BELLE RIVER AVE&DEGURSE AVE	MAKELLYP	C4041 - Speeding Citation
239	06/21/2023 03:44 PM	230001438	N BELLE RIVER AVE&DEGURSE AVE	MAKELLYP	C2931 - DWLS OPS License Suspended / Revoked
240	06/21/2023 05:29 PM	230001439	801 SCOTT ST	MAKELLYP	C3336 - Assist Citizen
241	06/21/2023 05:54 PM	230001440	6040 KING RD	MAKELLYP	C3150 - Property Damage H&R Traffic Crash
242	06/22/2023 01:16 AM	230001441	S WATER ST&BROADWAY ST	MADEKUNM	L3590 - Traffic Stop - MA
243	06/22/2023 01:22 AM	230001442	6760 RIVER RD	MADEKUNM	C3902 - Burglary Alarm
244	06/22/2023 02:58 AM	230001443	8742 PUTTYGUT RD	MADEKUNM	C3330 - Assist Other Law Enforcement Agency

#	DATE/TIME	INCIDENT #	LOCATION	OFFICER	OFFENSE
245	06/22/2023 08:25 AM	230001444	375 S PARKER ST	MABELLJ	C3330 - Assist Other Law Enforcement Agency
246	06/22/2023 10:03 AM	230001445	375 S PARKER ST	MABELLJ	C3330 - Assist Other Law Enforcement Agency
247	06/22/2023 10:24 AM	230001446	N BELLE RIVER AVE&DEGURSE AVE	MAJONESJ	L3590 - Traffic Stop - MA
248	06/22/2023 11:14 AM	230001447	S PARKER ST&THOMPSON DR	MAHEASLIPJ	L3590 - Traffic Stop - MA
249	06/22/2023 02:21 PM	230001448	1239 S PARKER ST	MAJONESJ	C3170 - Private Property Traffic Crash
250	06/22/2023 05:27 PM	230001449	HAROLD ST&PEARL ST	MAJONESJ	C3730 - Traffic Complaint / Traffic Miscellaneous A Complaint
251	06/22/2023 08:44 PM	230001450	CHARTIER RD&KING RD	NA	L3592 BOL - MA
252	06/22/2023 09:08 PM	230001451	N MAIN ST&BROADWAY ST	MAREDMAND	C3804 - Animal Complaint
253	06/22/2023 11:55 PM	230001452	750 SCOTT ST	MAREDMAND	C3324 - Suspicious Circumstances
254	06/23/2023 12:05 AM	230001453	725 LOWELL ST	MAREDMAND	C3355 - Civil Matter - Other
255	06/23/2023 09:03 AM	230001454	375 S PARKER ST	MABELLJ	L3522 - Records Check - MA
256	06/23/2023 11:12 AM	230001455	WEST BLVD&S PARKER ST	MAMARTINELLIC	C3145 - Property Damage Traffic Crash PDA
257	06/23/2023 01:28 PM	230001456	311 DELINA ST	MAMARTINELLIC	C3336 - Assist Citizen
258	06/23/2023 02:04 PM	230001457	375 S PARKER ST	MABELLJ	L3522 - Records Check - MA
259	06/23/2023 02:14 PM	230001458	S WATER ST&JEFFERSON ST	MAMARTINELLIC	L3590 - Traffic Stop - MA
260	06/23/2023 04:07 PM	230001459	126 S MARKET ST	MAMARTINELLIC	C3310 - Family Trouble
261	06/23/2023 05:18 PM	230001460	618 RIVER ST	MAKENYONT	C3324 - Suspicious Circumstances
262	06/23/2023 08:17 PM	230001461	255 GLADYS ST	MAREDMAND	C3250 - Mental Health Call
263	06/23/2023 09:25 PM	230001462	255 GLADYS ST	NA	L3542 Follow Up - MA
264	06/23/2023 10:25 PM	230001463	255 GLADYS ST	NA	L3592 BOL - MA
265	06/23/2023 11:03 PM	230001464	255 GLADYS ST	MAREDMAND	C3250 - Mental Health Call
266	06/23/2023 11:15 PM	230001465	520 S WATER ST	MAREDMAND	C3324 - Suspicious Circumstances
267	06/23/2023 11:28 PM	230001466	520 S WATER ST	MAREDMAND	C3324 - Suspicious Circumstances
268	06/24/2023 08:50 AM	230001467	375 S PARKER ST	MAMARTINELLIC	C3336 - Assist Citizen
269	06/24/2023 12:08 PM	230001468	225 PLEASANT ST	MAMARTINELLIC	C3799 - Miscellaneous Traffic Complaint
270	06/24/2023 01:00 PM	230001469	375 S PARKER ST	MAMARTINELLIC	C3250 - Mental Health Call
271	06/24/2023 01:11 PM	230001470	WEST BLVD&S PARKER ST	MAMARTINELLIC	C3804 - Animal Complaint

#	DATE/TIME	INCIDENT #	LOCATION	OFFICER	OFFENSE
272	06/24/2023 04:29 PM	230001471	S WATER ST&WASHINGTON ST	MAMARTINELLIC	L3590 - Traffic Stop - MA
273	06/24/2023 09:07 PM	230001472	N MARY ST&HOLLAND ST	MAKENYONT	L3590 - Traffic Stop - MA
274	06/24/2023 10:48 PM	230001473	512 WOODWORTH ST	MAREDMAND	L3515 - Disorderly House - Loud Party - MA
275	06/25/2023 12:22 AM	230001474	184 S BELLE RIVER AVE	MAREDMAND	C3336 - Assist Citizen
276	06/25/2023 02:47 AM	230001475	S WATER ST&BROADWAY ST	MAREDMAND	L3590 - Traffic Stop - MA
277	06/25/2023 08:45 AM	230001476	N MAIN ST&WOODWORTH ST	MAMARTINELLIC	C4041 - Speeding Citation
278	06/25/2023 09:15 AM	230001477	HOLLAND ST&N MAIN ST	MAMARTINELLIC	L3590 - Traffic Stop - MA
279	06/25/2023 09:40 AM	230001478	BROADWAY ST&N ELIZABETH ST	MAMARTINELLIC	L3590 - Traffic Stop - MA
280	06/25/2023 10:02 AM	230001479	N MAIN ST&HOLLAND ST	MAMARTINELLIC	L3590 - Traffic Stop - MA
281	06/25/2023 10:18 AM	230001480	KATHERINE ST&WEST BLVD	MAMARTINELLIC	C4080 - Distracted Driving
282	06/25/2023 12:58 PM	230001481	S WATER ST&WASHINGTON ST	MAMARTINELLIC	L3590 - Traffic Stop - MA
283	06/25/2023 01:20 PM	230001482	S WATER ST&E SAINT CLAIR ST	MAMARTINELLIC	L3590 - Traffic Stop - MA
284	06/25/2023 01:47 PM	230001483	S WATER ST&JEFFERSON ST	MAMARTINELLIC	C2931 - DWLS OPS License Suspended / Revoked
285	06/25/2023 04:21 PM	230001484	S WATER ST&WASHINGTON ST	MAMARTINELLIC	L3590 - Traffic Stop - MA
286	06/25/2023 04:26 PM	230001485	809 OAK ST	MAKENYONT	C3330 - Assist Other Law Enforcement Agency
287	06/25/2023 06:14 PM	230001486	240 S WATER ST	MAKENYONT	C3804 - Animal Complaint
288	06/25/2023 07:26 PM	230001487	233 S MARY ST	MAKENYONT	C3310 - Family Trouble
289	06/25/2023 07:36 PM	230001488	5505 RIVER RD	NA	L3542 Follow Up - MA
290	06/26/2023 05:22 AM	230001489	605 S PARKER ST	MAREDMAND	C3902 - Burglary Alarm
291	06/26/2023 11:36 AM	230001490	375 S PARKER ST	MAJONESJ	2674 - Fraud (Larceny) by Conversion [26001]
292	06/26/2023 12:01 PM	230001491	375 S PARKER ST	MAJONESJ	C3336 - Assist Citizen
293	06/26/2023 12:21 PM	230001492	375 S PARKER ST	MABELLJ	L3522 - Records Check - MA
294	06/26/2023 12:31 PM	230001493	336 UNION ST	MABELLJ	L3520 - Pistol Sales Record - MA
295	06/26/2023 02:15 PM	230001494	375 S PARKER ST	MAJONESJ	C3336 - Assist Citizen
296	06/26/2023 05:02 PM	230001495	545 WARD ST	MAJONESJ	C3324 - Suspicious Circumstances
297	06/26/2023 08:57 PM	230001496	750 SCOTT ST	NA	L3542 Follow Up - MA
298	06/26/2023 09:06 PM	230001497	211 PLEASANT ST	NA	L3542 Follow Up - MA

#	DATE/TIME	INCIDENT #	LOCATION	OFFICER	OFFENSE
299	06/27/2023 01:14 PM	230001498	515 E SAINT CLAIR ST	MAJONESJ	C3299 - Welfare Check
300	06/27/2023 01:24 PM	230001499	METROPOLIS ST&N PARKER ST	MAJONESJ	C2845 - Juvenile - Safety Violations
301	06/27/2023 03:19 PM	230001500	6764 RIVER RD	MAJONESJ	C3336 - Assist Citizen
302	06/27/2023 03:49 PM	230001501	147 S PARKER ST	MAJONESJ	C3331 - Assist Medical
303	06/28/2023 07:32 AM	230001502	156 CARROLL ST	MABELLJ	L3520 - Pistol Sales Record - MA
304	06/28/2023 07:45 AM	230001503	375 S PARKER ST	MABELLJ	L3522 - Records Check - MA
305	06/28/2023 09:23 AM	230001504	531 BRUCE ST	MAMARTINELLIC	C3324 - Suspicious Circumstances
306	06/28/2023 10:40 AM	230001505	1109 WEST BLVD	MAMARTINELLIC	2609 - Identity Theft [26007]
307	06/28/2023 11:55 AM	230001506	375 S PARKER ST	MAMARTINELLIC	C3336 - Assist Citizen
308	06/28/2023 12:31 PM	230001507	375 S PARKER ST	MABELLJ	L3545 - FLOCK Investigation - MA
309	06/28/2023 01:06 PM	230001508	375 S PARKER ST	MABELLJ	L3522 - Records Check - MA
310	06/28/2023 01:20 PM	230001509	S MARY ST&WASHINGTON ST	MAMARTINELLIC	C3331 - Assist Medical
311	06/28/2023 01:58 PM	230001510	310 S BELLE RIVER AVE	MABELLJ	C3318 - Found Property
312	06/28/2023 02:15 PM	230001511	1109 S BELLE RIVER AVE	MAMARTINELLIC	C3355 - Civil Matter - Other
313	06/28/2023 02:48 PM	230001512	537 E SAINT CLAIR ST	MAMARTINELLIC	C3299 - Welfare Check
314	06/28/2023 07:50 PM	230001513	5253 HESSEN RD	NA	L3542 Follow Up - MA
315	06/28/2023 09:35 PM	230001514	719 HONEY LOCUST CT	MAKENYONT	C3330 - Assist Other Law Enforcement Agency
316	06/28/2023 09:48 PM	230001515	S WILLIAM ST&WASHINGTON ST	MAREDMAND	L3550 - Fireworks Complaint - MA
317	06/28/2023 10:28 PM	230001516	7137 MARSH RD	MAKENYONT	C3330 - Assist Other Law Enforcement Agency
318	06/29/2023 07:53 AM	230001517	N MAIN ST&WOODWORTH ST	MAMARTINELLIC	L3590 - Traffic Stop - MA
319	06/29/2023 08:09 AM	230001518	JEFFERSON ST&S MAIN ST	MAMARTINELLIC	L3590 - Traffic Stop - MA
320	06/29/2023 08:32 AM	230001519	BROADWAY ST&N ELIZABETH ST	MAMARTINELLIC	L3590 - Traffic Stop - MA
321	06/29/2023 08:50 AM	230001520	BROADWAY ST&N ELIZABETH ST	MAMARTINELLIC	L3590 - Traffic Stop - MA
322	06/29/2023 09:05 AM	230001521	WESTMINSTER ST&N MAIN ST	MAMARTINELLIC	L3590 - Traffic Stop - MA
323	06/29/2023 09:18 AM	230001522	327 BELL ST	MAMARTINELLIC	C3902 - Burglary Alarm
324	06/29/2023 11:23 AM	230001523	756 S MAIN ST	MAMARTINELLIC	C3324 - Suspicious Circumstances
325	06/29/2023 01:46 PM	230001524	CHARTIER RD&S PARKER ST	MAMARTINELLIC	L3590 - Traffic Stop - MA
326	06/29/2023 02:36 PM	230001525	CHARTIER RD&CATHERINE ST	MAKENYONT	L3590 - Traffic Stop - MA

#	DATE/TIME	INCIDENT #	LOCATION	OFFICER	OFFENSE
327	06/29/2023 03:24 PM	230001526	S WATER ST&JEFFERSON ST	MAMARTINELLIC	L3590 - Traffic Stop - MA
328	06/29/2023 03:58 PM	230001527	S WATER ST&BRIDGE ST	MAMARTINELLIC	L3590 - Traffic Stop - MA
329	06/29/2023 04:17 PM	230001528	820 ROBERTSON ST	MAKENYONT	C3331 - Assist Medical
330	06/29/2023 07:24 PM	230001529	S PARKER ST&CHARTIER RD	MADEKUNM	L3590 - Traffic Stop - MA
331	06/29/2023 07:36 PM	230001530	1229 S PARKER ST	MADEKUNM	L3590 - Traffic Stop - MA
332	06/29/2023 07:41 PM	230001531	1295 S PARKER ST	MADEKUNM	L3590 - Traffic Stop - MA
333	06/29/2023 07:47 PM	230001532	1295 S PARKER ST	MADEKUNM	L3590 - Traffic Stop - MA
334	06/29/2023 07:54 PM	230001533	S PARKER ST&SCOTT ST	MADEKUNM	L3590 - Traffic Stop - MA
335	06/29/2023 08:16 PM	230001534	424 PITTSBURGH ST	MADEKUNM	C3336 - Assist Citizen
336	06/29/2023 09:02 PM	230001535	534 MABEL ST	MAKENYONT	C3324 - Suspicious Circumstances
337	06/30/2023 03:09 AM	230001536	516 S PARKER ST	MAKENYONT	C3324 - Suspicious Circumstances
338	06/30/2023 11:18 AM	230001537	534 MABEL ST	NA	L3542 Follow Up - MA
339	06/30/2023 03:10 PM	230001538	S PARKER ST&DELINA ST	MAKELLYP	L3590 - Traffic Stop - MA
340	06/30/2023 03:06 PM	230001539	261 HURON LN	MAVANDERMEULENJ	C3336 - Assist Citizen
341	06/30/2023 03:48 PM	230001540	S PARKER ST&BRUCE ST	MAKELLYP	L3590 - Traffic Stop - MA
342	06/30/2023 04:07 PM	230001541	S PARKER ST&DELINA ST	MAKELLYP	L3590 - Traffic Stop - MA
343	06/30/2023 04:23 PM	230001542	S PARKER ST&DELINA ST	MAKELLYP	L3590 - Traffic Stop - MA
344	06/30/2023 04:45 PM	230001543	S PARKER ST&DELINA ST	MAKELLYP	L3590 - Traffic Stop - MA
345	06/30/2023 05:37 PM	230001544	N MAIN ST&PEARL ST	MAKELLYP	L3590 - Traffic Stop - MA
346	06/30/2023 05:40 PM	230001545	WEST BLVD&N PARKER ST	MAVANDERMEULENJ	L3590 - Traffic Stop - MA
347	06/30/2023 06:27 PM	230001546	BROADWAY ST&S MARY ST	MAVANDERMEULENJ	C4080 - Distracted Driving
348	06/30/2023 06:37 PM	230001547	S PARKER ST&CHARTIER RD	MAKELLYP	L3590 - Traffic Stop - MA
349	06/30/2023 07:11 PM	230001548	S PARKER ST&W SAINT CLAIR ST	MAKELLYP	L3590 - Traffic Stop - MA
350	06/30/2023 07:55 PM	230001549	N PARKER ST&WEST BLVD	MAKELLYP	L3590 - Traffic Stop - MA
351	06/30/2023 08:27 PM	230001550	N PARKER ST&WEST BLVD	MAKELLYP	L3590 - Traffic Stop - MA
352	06/30/2023 08:26 PM	230001551	242 N ELIZABETH ST	MAKELLYP	C3331 - Assist Medical
353	06/30/2023 09:19 PM	230001552	1315 S WATER ST	MAKELLYP	C3299 - Welfare Check
354	06/30/2023 09:57 PM	230001553	KING RD&WEST BLVD	MADEKUNM	L3590 - Traffic Stop - MA
355	06/30/2023 11:03 PM	230001554	S PARKER ST&BOWERY ST	MAKELLYP	C4041 - Speeding Citation
356	06/30/2023 11:48 PM	230001555	7025 MARINE CITY HWY	MAKELLYP	C3330 - Assist Other Law Enforcement Agency

#	DATE/TIME	INCIDENT #	LOCATION	OFFICER	OFFENSE
357	06/30/2023 11:46 PM	230001556	5934 KING RD	MAKELLYP	C3332 - Assist Fire Department

Job Category	Location	Activity	Equipment	Hours
Building Maintenance	WWTP/WW/Belle River Pump Station/260 S. Parker	WWTP: General repairs; Water Plant: General repairs; 260 S. Parker: Maintenance, Elections; BRPS: General repairs; 300 Broadway: Maintenance	Camel, '16 Silverado, '06 Silverado, '15 Silverado, 1 Ton, JCB	71.5
Banners / Decorations / Flags	Marine City	Install/Maintain Banners & Decorations	Boom Truck	11
Review Plans		Road Project / Road Assessment		0
Cemetery Maint./ Burials/ Columbarium	Woodlawn Cemetery	Routine Maintenance / Probes / Burials / Footings		12
Sidewalks	Marine City & DPW	Maintenance / Office	1 Ton	0
Equipment / Vehicle Maintenance	DPW	Repairs / Maintenance / Preventative Care	Sweeper, Camel, 4052r John Deere, JCBs, Sterlings, Pumps, Trucks	30.5
Office	DPW	Misc. Office Duties / Reports / Meetings / Budget / Marina Project / Christopher & Dana Reeve Foundation Grant / Field Work/ EGLE Reports/ Cross Connection		328
Beach Attendants	Beach			286
Flower Watering	Marine City			50
Grass Cutting	Buildings & Parks			219.5
Park Maintenance	Marine City	Garbage Pickup/ General Maintenance	'06 Silverado, 1 Ton	170.5
Routine Road Maintenance / Road Projects	Local/Major Roads/Parking Lots	Cold Patching/ Hot Patching/ Misc. Maintenance/ Sweeping	'06 Silverado, Camel, '18 JCB, '14 JD Sweeper	68
Sanitary Sewer Maintenance	Marine City	Clean Sanitary Sewers/ Sanitary Sewer Maintenance/ Inspection	'06 Silverado, Camel, Silverado	0
Shop Maintenance	DPW	Shop Repairs/ Maint./ Cleaning		24
Signs	Marine City		'15 Silverado	16
Storm Sewer Maintenance	Marine City	Catch Basin Cleaning/ Storm Sewer Maintenance & Locating	'06 Silverado, Camel	11
Bridge	Marine City	Maintenance/ Kayak Launch	1 Ton	1.5
Water System Maintenance	Marine City	Water Leaks & leak Investigation/ Curb Box Maint./ Misc. Maint./ Service Line Maint. & Replace/ Meters/ Final Reads/ Water Turn On & Off / Shutoffs / MissDigs/ Valve locate/ Hydroexcavating/ Service line replace/ Cross Connection	'06 Silverado, Camel	202
Training	Marine City			0
Upcoming Projects:			Total Hours:	1501.5
Water Service Line Replacement & Inventory - Screw Pump Repair				

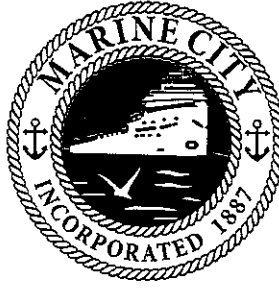

TO: Scott Adkins, City Manger
FROM: Jim Schafer
DATE: July 11, 2023
SUBJECT: June Code Enforcement Activity Report

Outstanding Blight Complaints;

Four with waiting on how to proceed from the City Attorney

One in the process of the evicting renter and remove the blight.

Blight Complaints;

Two with letters sent to return to compliance.

Grass Complaints;

Several with letters sent to return to compliance, if not cut by the homeowner after the first letter DPW advised to cut and charge the homeowner with the charge for services payable at the City offices.

Vacant Building;

Nothing to report.

Parking Complaints;

One sent to MCPD to handle.

One for a travel trailer on vacant property, property owner was advised to remove within 24hrs.

Fence Complaint;

Nothing to report.

Sign Removal;

A few signs removed or moved from the City easement.

**City of Marine City
300 Broadway Committee Meeting Minutes
May 22, 2023**

A regular meeting of the 300 Broadway Committee was held on Monday, May 22, 2023, at 260 S. Parker Street, Marine City, MI 48039 and was called to order at 5:02 pm by Chairperson Brian Ross.

A moment of silence was led by Chairperson Ross.

The Pledge of Allegiance was led by Chairperson Ross.

Present: Chairperson Brian Ross, Committee Members Michelle Nichter, Cheryl Ross, Kim Turner; Deputy Clerk Michele Goodrich.

Absent: Vice Chairperson Laura Merchant, Members Andrew Pakledinaz and Sheryl Zimmer, City Manager Scott Adkins.

Motion by Committee Member Nichter, seconded by Member B. Ross, to excuse Members Pakeldinaz, Merchant, and Zimmer from the meeting. All Ayes. Motion Carried.

Approve Agenda

Motion by Committee Member Ross, seconded by Committee Member B. Ross, to approve the agenda. All Ayes. Motion Carried.

Public Comment

None.

Approve Minutes

Motion by Committee Member C. Ross, seconded by Committee Member Turner, to approve the 300 Broadway Committee Meeting Minutes of April 24, 2023. All Ayes. Motion Carried.

Unfinished Business

Building Priorities

Committee Member Nichter informed that there was still dampness where the roof leak was occurring. DPW Superintendent Schmidt was informed the issue and advised he would look at the area.

Committee Member Nichter advised that the fire suppression system was fixed however, questioned what needed to be done regarding annual inspections or an inspection schedule. She

also stated that she would forward Poe's quote regarding masonry repairs to DPW Superintendent Schmidt.

Project Priorities

Chairperson Ross discussed the need to continue to look for available grant opportunities and addressed the RAP grant opportunity that was a dollar for dollar match.

Endowment Activities

Heather Bokram addressed additional potential funding from the next poker night and the possibility of campaign fundraising near September.

New Business

None.

Open Discussion

Deputy Clerk Goodrich questioned if the new 300 Broadway Bandstand was going to be a rentable or reservable structure.

Chairperson B. Ross advised that he would request that the discussion regarding the bandstand be added to the City Commission agenda.

Adjournment

Motion by Committee Member C. Ross, seconded by Committee Member Turner, to adjourn at 5:52 pm. All Ayes. Motion Carried.

Respectfully submitted,

Michele E. Goodrich
Deputy Clerk

Jason Bell
Interim City Clerk

**City of Marine City
Zoning Board of Appeals
April 5, 2023**

A regular meeting of the Marine City Zoning Board of Appeals was held on Wednesday, April 5, 2023 at 260 South Parker St., Marine City, and was called to order by Chairperson Weil at 7:00 pm.

The Pledge of Allegiance was led by Chairperson Weil.

Present: Chairperson Kim Weil; Board Members Mark Bassham, James Turner; Planning Commissioner Graham Allan; City Commissioner Rita Roehrig; interim City Manager Jim Heaslip, Interim City Clerk Jason Bell

Also in Attendance: Building Official Tracy Kallek

Communications

None.

Approve Agenda

Motion by Board Member Turner, seconded by Board Member Bassham, to approve the Agenda. All Ayes. Motion Carried.

Public Comment

None.

Approve Minutes

Motion by Planning Commissioner Allan, seconded by Board Member Turner to approve the Minutes of the Regular Meeting of the Zoning Board of Appeals held December 7, 2022. All Ayes. Motion Carried.

Unfinished Business

None.

New Business

Public Hearing – Variance #23-01: 6609 S Parker Street.

Chairperson Weil announced that the Zoning Board of Appeals would conduct a Public Hearing to receive public comments for and against the proposed Variance request by K&M Developments regarding 6609 S Parker Street and opened the Public Hearing at 7:02 P.M.

Interim City Manager Heaslip stated the address on the application was incorrect and it should be 6609 S River Road.

Ben Tiseo, architect for the project, spoke on the variance request and stated the set back variance would allow a road for vehicles to enter in a counterclockwise motion to back in to spots safely. He also stated the plan was to keep the current residence and remodel for office space and that the property could use a little help to bring it out of it's current state. He stated the approval of this variance would allow the project to move forward as planned.

Board Member Turner stated the address on the print was incorrect as well and should be fixed before this is sent to the Planning Commission, Mr. Tiseo stated he would have that corrected.

Chairperson Weil inquired if any objections to the variance request had been received, Interim City Clerk Bell stated there had not been.

Board Member Turner inquired why the set back was 50 foot on the Northern lot line and only 10 foot on the Southern lot line. Building Official Kallek stated that was in the ordinance and the Southern lot line bordered the Township.

Chairperson Weil called to the audience three times, requesting if anyone wanted to be heard on Variance Request 23-01. Hearing none, he declared the Public Hearing closed at 7:12 P.M.

Motion by Planning Commissioner Allan, seconded by City Commissioner Roehrig, to grant the variance based on the application, the applicant's presentation and testimony, the record presented at the hearing and based on the following particulars which support the variance sought: requested variance of 27'6", will not be contrary to the spirit and

intent of the set back ordinance and it also improves the current non-conformity. **Roll Call Vote.** Ayes: Weil, Allan, Bassham, Turner, Roehrig. Nays: None. Motion Carried.

Adjournment

Motion by Board Member Turner, seconded by Chairperson Weil, to adjourn at 7:15 pm. All Ayes. Motion Carried.

Respectfully submitted,

Jason A. Bell
Interim City Clerk

Shannon Adams
City Clerk

**City of Marine City
Planning Commission Meeting Minutes
May 22, 2023**

A re-scheduled meeting of the Marine City Planning Commission was held on Monday, May 22, 2023 at 260 South Parker Street, and was called to order by Chairperson Moran at 6:03 pm.

The Pledge of Allegiance was led by Chairperson Moran.

Present: Chairperson Joseph Moran; Commissioners Graham Allan, Madelyn McCarthy, William Beutell; City Manager Scott Adkins; Deputy Clerk Michele Goodrich

Absent: Keith Jenken, Andrew Pakledinaz, William Klaassen

Motion by Commissioner Allan, seconded by Commissioner Beutell, to excuse Commissioners Jenken and Pakledinaz from the meeting. All Ayes. Motion Carried.

Communications

None.

Approve Agenda

Motion by Commissioner Beutell, seconded by Commissioner Allan, to approve the agenda. All Ayes. Motion Carried.

Public Comment

None.

Approve Minutes

Motion by City Commissioner Beutell, seconded by Commissioner Allan, to approve the April 10, 2023 meeting minutes. All Ayes. Motion Carried.

Unfinished Business

Marjuana Facility – Detailed Zoning based on 1000 feet

Chairperson Moran informed the Board that the City Commission had requested that the Planning Commission provide them with detailed zoning maps, inclusive of plots, based on 1000' setbacks.

Motion by Commissioner McCarthy, seconded by Commissioner Beutell, to approve the detailed zoning maps based on 1000 feet, and to forward them to the City Commission. All Ayes. Motion Carried.

Commissioner Allan made comment that he hoped the City maintained the Ordinance on file regarding marijuana facilities.

New Business

Master Plan Update – McKenna

McKenna representative, Brigitte Smith, briefly reviewed the Master Plan Kick-Off Meeting packet including a schedule of events and who comprised of the core review team. City Manager Adkins informed the Board that he had requested information regarding a potential data sharing agreement between St. Clair County and Marine City for Master Plan purposes.

Ms. Smith addressed the need to look into potential redevelopment/change areas, including waterfront properties, public lands and vacant lands and any potential zoning and future land use changes.

The Kick-Off packet highlighted possible hot button issues, such as downtown parking and Old City Hall, if there may be future parking revisions that should be addressed, potential tourism and recreation based issues, and the outreach and advertising outlets regarding the Master Plan revisions.

Chairperson Moran requested the Master Plan focus on historic preservation and putting an emphasis on keeping with a cohesive historic look for buildings.

The Planning Commission reviewed the potential community questionnaire facilitated by McKenna and recommended slight modifications regarding wording and recommended attaching pictures or addresses to the list of City parks.

Ms. Smith advised conveyed her belief that it was a great kick-off meeting and that if anyone had any suggestions or input to forward their inquiry(ies) to the City Manager and that she would be in contact with City Manager Adkins as the City moves forward with community engagement sessions.

Adjournment

Motion by Commissioner Beutell, seconded by Commissioner Moran, to adjourn at 8:05pm. All Ayes. Motion Carried.

Respectfully submitted,

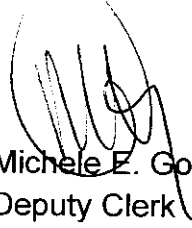

Michele E. Goodrich
Deputy Clerk

Jason Bell
Interim City Clerk



City of Marine City
 Department of the City Clerk
 260 S. Parker St.
 Marine City, MI 48039
 (810) 765-8830
kbaxter@marinecity-mi.org

7f

**Speci:
 Permit App**

Applicatio
 Submit 90 Days Prior to
 CASH/MONEY ORDER
 Cash Receipti

The City of Marine City may impose restrictions on any special event in the interest of the health and safety of residents and participants. The applicant may be required to indemnify the city for and hold it harmless from and defend it against any and all claims, lawsuits or other liability. **Approval of the Special Event Permit Application and event date is subject to final approval of the City Commission, based on other activities occurring within the community.**

Application Date: March 26, 2023

APPLICANT INFORMATION

Applicant/Sponsor of Event: MARINE CITY FESTIVAL, INC

Is Sponsor of Event a Non-Profit Organization? Yes No

Contact Person: Tammi Graber

Contact Number: [REDACTED]

Email: maritimedays@yahoo.com

Mailing Address: PO BOX 192, MARINE CITY, MI 48039

EVENT INFORMATION

Name of Event: Maritime Days

Date/Hours of Event: August 4-6, 2023

Location of Event: Uptown Marine City- Water St. / parks on Water St., Parade Route.

Will alcoholic beverages be served? Yes No

-Have you applied for a liquor license? Yes No (*If yes, please provide a copy)

Provide a detailed description of event (attach additional sheets, if necessary): _____

Festival with Beverage/entertainment Tent, Parade, Fishing tournament, Car show, Vendors/events on Water street

Are utility hook-ups required? Yes No

Location: Drake Park

Will street closures be necessary? Yes No

If yes, include a detailed map and indicate the date and time for closing and re-opening, including set-up and tear-down: see attached

Is handicap/special parking needed? If yes, please explain: NO

Applicant/Sponsor of Event is responsible for providing trash receptacles and portable restrooms.

Indicate number of portable restrooms for event: Regular 4 Handicapped 4

Will you be posting signs for the Special Event? If so, include proposed locations: YES. CITY SPECIFIED

LOCATIONS

PLEASE NOTE: Signs may not be placed at street corners blocking vision, or in easements. Please refer to City Ordinances for specifics.

ALSO, PLEASE NOTE: Street marking is PROHIBITED! Traffic cones and signage are acceptable, but all cones and signs must be removed immediately after the event.

AGREEMENT & INDEMNIFICATION

The City of Marine City will provide the event organizers an estimate of fees for city services. The event organizers shall be given an opportunity to review these estimates prior to approval of the event. The final amount billed to the organizers will not exceed the estimated amount unless:

- There have been additional city costs due to cleanup or repairs of damaged property.
- Additional city services were provided as a result of changes in the requirements as requested by event organizers.

Applicants / Sponsors are to submit a 50% deposit of their estimated portion of costs within (30) days of their application being approved. They will be billed for the remainder of the ACTUAL costs after the event. Failure to pay the final bill within thirty (30) days of the invoice date will result in denial of application the following year.

Applicant additionally agrees to provide the City of Marine City a Certificate of Insurance naming it as an "Additional Insured" in an amount of not less than One Million Dollars (\$1,000,000) as a condition for approval of this event.

As the authorized agent of the sponsoring organization, I hereby agree that this organization shall abide by all conditions and restrictions specific to this event as determined by the City of Marine City, and will comply with all local, state and federal rules, regulations and laws.



Applicant Signature

March 26, 2023

Date

TG Indemnification and Hold Harmless Agreement: By way of my initials here and my full signature below, I hereby acknowledge that to the fullest extent of the law, agree to indemnify and hold harmless the City of Marine City ("City"), its elected and appointed officials, employees, and volunteers from any and all liability, claims, demands, costs, and judgments, related to bodily injury or property damage, including attorney's fees, that the City incurs as a result of acts or omissions of Applicant and/or its agents arising from this event.

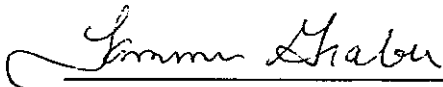

Applicant Signature

March 26, 2023

Date

DEPARTMENT ROUTING SHEET
(For Internal Use Only)

Department	Estimated Costs	Comments	Actual Costs
POLICE	\$ 1019.08		
DPW	\$ 215.00		
FIRE	0		

Total Estimated Costs: \$ 1234.08

CITY USE

\$25.00 Application Fee Received: _____

Application reviewed / approved by the following departments:

Police Chief _____

DPW _____

Fire Chief _____

City Manager _____

Approved by the City Commission on:

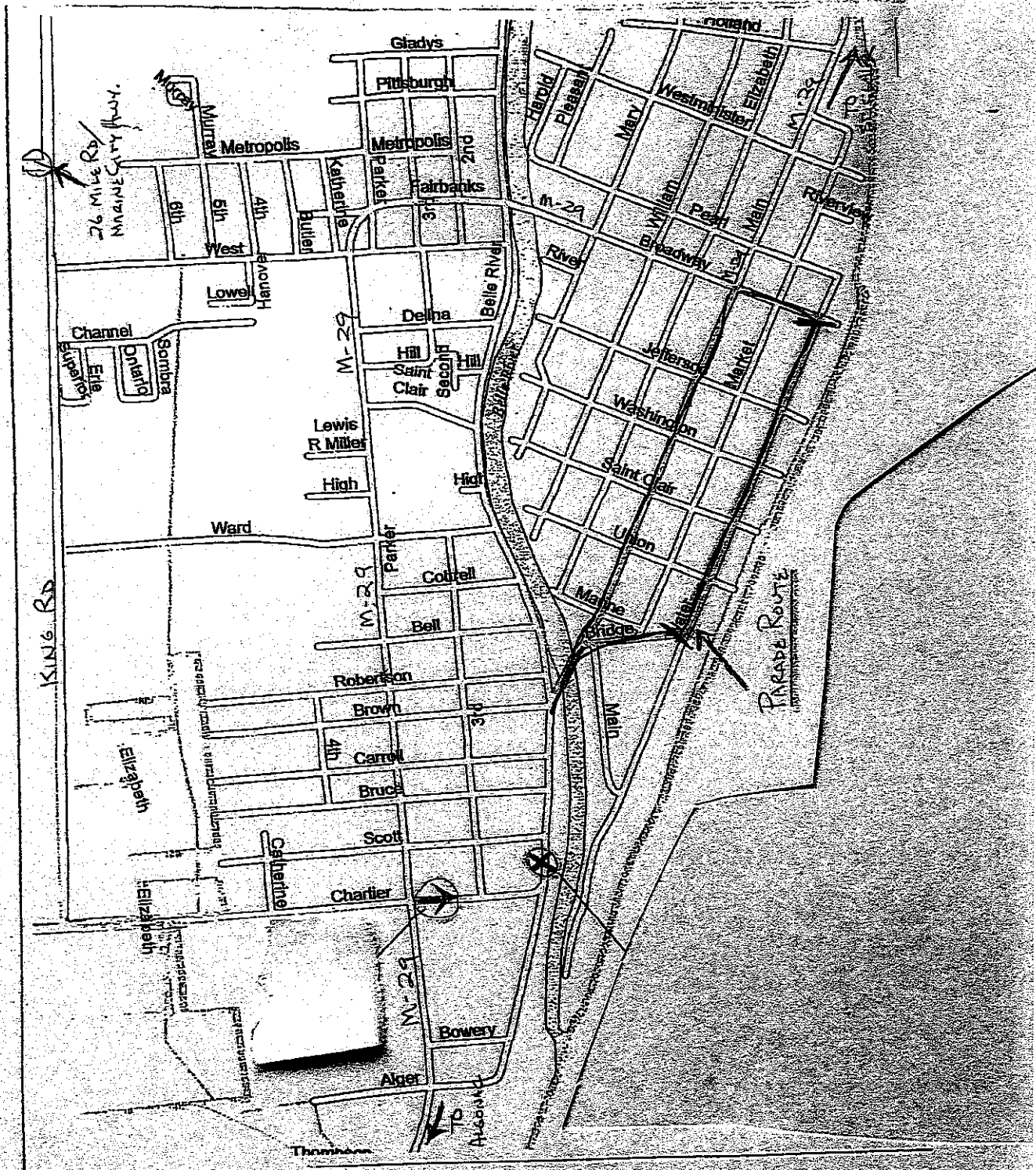

Maritime Days

Aug 4-6

close water st

from

Bridge to ~~Jefferson~~ Jefferson



Festival Tent in



Nautical Park



Marine City Police Department

James D. Heaslip
Chief of Police

375 S. Parker Street ● Marine City, Michigan 48039
(810) 765-4040 ● Fax (810) 765-4135

June 28, 2023

Michele Goodrich
260 S. Parker St.
Marine City, MI 48039

Michele,

Here is a breakdown of the hours needed for the 2023 Maritime Days.

Friday	-	1 Full Time Officer @ \$43.40 x 4 hrs OT	=	\$173.60
Saturday	-	1 Part Time Officer @ \$25 x 9 hrs	=	\$225
		\$26 x 1 hr	=	\$26
Sunday	-	1 Full Time Officer @ \$47.19 x 6 hrs	=	\$283.14
		1 Full Time Officer @ \$51.59 x 6 hrs	=	\$311.34

TOTAL COSTS = \$1019.08

If you should have any further questions, please feel free and contact me.

Respectfully Submitted,

James D. Heaslip
Chief of Police

“ To Protect and Serve ”



CITY OF
MARINE CITY
DEPARTMENT OF PUBLIC WORKS
514 S. PARKER ST.
MARINE CITY, MICHIGAN 48039
(810) 765-9711 · Fax (810) 765-1796

To: Merritime Days Committee
From: Jeff Schmidt, DPW Superintendent
Date: June 28, 2023
Subject: DPW Labor Hours

To Whom It May Concern,

Please find the breakdown below for two DPW employees working for two hours on Sunday August 6, 2023.

Employee A: 2 hours @ \$52.42/hour= \$104.84

Employee B: 2 hours @ \$55.08/hour= \$110.16

Total cost: \$215

Respectfully,

A handwritten signature in black ink, appearing to read "Jeff Schmidt", is written over a horizontal line.

Jeffrey Schmidt
DPW Superintendent

*"In the Heart of Blue Water District"
Marine City is an Equal Opportunity Provider*

Permit Application



City of Marine City
Department of the City Clerk
260 S. Parker
Marine City, MI 48039
(810) 765-8830
kbaxter@cityofmarinecity.org

Application Fee: \$25.00
Submit 90 Days Prior to Start of Event
CASH/MONEY ORDER/CHECK ONLY
Cash Receipting Code: S/E

The City of Marine City may impose restrictions on any special event in the interest of the health and safety of residents and participants. The applicant may be required to indemnify the city for and hold it harmless from and defend it against any and all claims, lawsuits or other liability. Approval of the Special Event Permit Application and event date is subject to final approval of the City Commission, based on other activities occurring within the community.

Application Date: 6/20/23

APPLICANT INFORMATION

Applicant/Sponsor of Event: Sheila Dzedzic / Community Pride and Heritage, Inc.

Is Sponsor of Event a Non-Profit Organization? [X] Yes [] No

Contact Person: Sheila Dzedzic

Contact Number: []

Email: []

Mailing Address: []

EVENT INFORMATION

Name of Event: Concert in the Park

Date/Hours of Event: August 21, 2023 7pm to 9pm

Location of Event: Broadway Park

Will alcoholic beverages be served? [] Yes [X] No

-Have you applied for a liquor license? [] Yes [X] No (*If yes, please provide a copy)

Provide a detailed description of event (attach additional sheets, if necessary):

East China Community Band will play a selection of different tune. The audience will bring their own seating. Part way through the concert we collect free will donations to help support the museum

Are utility hook-ups required? [] Yes [X] No

Location: []

Will street closures be necessary? [] Yes [X] No

If yes, include a detailed map and indicate the date and time for closing and re-opening, including set-up and tear-down: []

Is handicap/special parking needed? If yes, please explain: No

Applicant/Sponsor of Event is responsible for providing trash receptacles and portable restrooms.

Indicate number of portable restrooms for event: Regular _____ Handicapped _____

Will you be posting signs for the Special Event? If so, include proposed locations: _____

N/A

PLEASE NOTE: Signs may not be placed at street corners blocking vision, or in easements. Please refer to City Ordinances for specifics.

ALSO, PLEASE NOTE: Street marking is PROHIBITED! Traffic cones and signage are acceptable, but all cones and signs must be removed immediately after the event.

AGREEMENT & INDEMNIFICATION

The City of Marine City will provide the event organizers an estimate of fees for city services. The event organizers shall be given an opportunity to review these estimates prior to approval of the event. The final amount billed to the organizers will not exceed the estimated amount unless:

- There have been additional city costs due to cleanup or repairs of damaged property.
- Additional city services were provided as a result of changes in the requirements as requested by event organizers.

Applicants / Sponsors are to submit a 50% deposit of their estimated portion of costs within (30) days of their application being approved. They will be billed for the remainder of the ACTUAL costs after the event. Failure to pay the final bill within thirty (30) days of the invoice date will result in denial of application the following year.

Applicant additionally agrees to provide the City of Marine City a Certificate of Insurance naming it as an "Additional Insured" in an amount of not less than One Million Dollars (\$1,000,000) as a condition for approval of this event.

As the authorized agent of the sponsoring organization, I hereby agree that this organization shall abide by all conditions and restrictions specific to this event as determined by the City of Marine City, and will comply with all local, state and federal rules, regulations and laws.

Shula A Dziedzic
Applicant Signature



6/20/23
Date

Ad: *N/A City owned properties*
Indemnification and Hold Harmless Agreement: By way of my initials here and my full signature below, I hereby acknowledge that to the fullest extent of the law, agree to indemnify and hold harmless the City of Marine City ("City"), its elected and appointed officials, employees, and volunteers from any and all liability, claims, demands, costs, and judgments, related to bodily injury or property damage, including attorney's fees, that the City incurs as a result of acts or omissions of Applicant and/or its agents arising from this event.

Shula A Dziedzic
Applicant Signature

6/20/23
Date

DEPARTMENT ROUTING SHEET
(For Internal Use Only)

Department	Estimated Costs	Comments	Actual Costs
POLICE			
DPW			
FIRE			

Total Estimated Costs: \$ _____

CITY USE

\$25.00 Application Fee Received: 6/20/2023

Application reviewed / approved by the following departments?

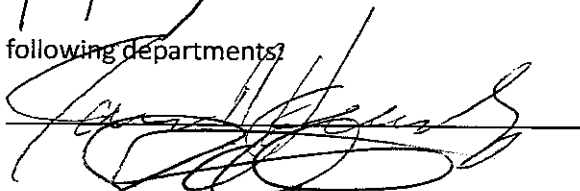
Police Chief 

DPW 

Fire Chief 

City Manager 

Approved by the City Commission on:



City of Marine City
 Department of the City Clerk
 260 S. Parker
 Marine City, MI 48039
 (810) 765-8830
clerk@cityofmarinecity.org

7h

RECEIVED

JUN 01 2023

City of Marine City

**Special Event
 Permit Application**

Application Fee: \$25.00
 Submit 90 Days Prior to Start of Event
 CASH/MONEY ORDER/CHECK ONLY
 Cash Receipting Code: S/E

The City of Marine City may impose restrictions on any special event in the interest of the health and safety of residents and participants. The applicant may be required to indemnify the city for and hold it harmless from and defend it against any and all claims, lawsuits or other liability. **Approval of the Special Event Permit Application and event date is subject to final approval of the City Commission, based on other activities occurring within the community.**

Application Date: 5/17/2023

APPLICANT INFORMATION

Applicant/Sponsor of Event: Marine City High School

Is Sponsor of Event a Non-Profit Organization? Yes No

Contact Person: Amanda Duetsch

Contact Number: -----

Email: -----

Mailing Address: 1085 Ward St. Marine City MI, 48039

EVENT INFORMATION

Name of Event: Homecoming Parade

Date/Hours of Event: October 13th, 2023

Location of Event: S. Water Street

Will alcoholic beverages be served? Yes No

-Have you applied for a liquor license? Yes No (*If yes, please provide a copy)

Provide a detailed description of event (attach additional sheets, if necessary): Our Homecoming

Parade will start on Water Street in front of Holy Cross and will head to Marine City Beach.

Are utility hook-ups required? Yes No

Location: -----

Will street closures be necessary? Yes No

If yes, include a detailed map and indicate the date and time for closing and re-opening, including set-up and tear-down: Our Parade will start at 5:00pm on South Water street.

Is handicap/special parking needed? If yes, please explain: -----

Applicant/Sponsor of Event is responsible for providing trash receptacles and portable restrooms.

Indicate number of portable restrooms for event: Regular _____ Handicapped _____

Will you be posting signs for the Special Event? If so, include proposed locations: N/A

PLEASE NOTE: Signs may not be placed at street corners blocking vision, or in easements. Please refer to City Ordinances for specifics.

ALSO, PLEASE NOTE: Street marking is PROHIBITED! Traffic cones and signage are acceptable, but all cones and signs must be removed immediately after the event.

AGREEMENT & INDEMNIFICATION

The City of Marine City will provide the event organizers an estimate of fees for city services. The event organizers shall be given an opportunity to review these estimates prior to approval of the event. The final amount billed to the organizers will not exceed the estimated amount unless:

- There have been additional city costs due to cleanup or repairs of damaged property.
- Additional city services were provided as a result of changes in the requirements as requested by event organizers.

Applicants / Sponsors are to submit a 50% deposit of their estimated portion of costs within (30) days of their application being approved. They will be billed for the remainder of the ACTUAL costs after the event. Failure to pay the final bill within thirty (30) days of the invoice date will result in denial of application the following year.

Applicant additionally agrees to provide the City of Marine City a Certificate of Insurance naming it as an "Additional Insured" in an amount of not less than One Million Dollars (\$1,000,000) as a condition for approval of this event.

As the authorized agent of the sponsoring organization, I hereby agree that this organization shall abide by all conditions and restrictions specific to this event as determined by the City of Marine City, and will comply with all local, state and federal rules, regulations and laws.

Applicant Signature



Date

AD _____ Indemnification and Hold Harmless Agreement: By way of my initials here and my full signature below, I hereby acknowledge that to the fullest extent of the law, agree to indemnify and hold harmless the City of Marine City ("City"), its elected and appointed officials, employees, and volunteers from any and all liability, claims, demands, costs, and judgments, related to bodily injury or property damage, including attorney's fees, that the City incurs as a result of acts or omissions of Applicant and/or its agents arising from this event.

Applicant Signature

Date

DEPARTMENT ROUTING SHEET
(For Internal Use Only)

Department	Estimated Costs	Comments	Actual Costs
POLICE			
DPW			
FIRE			

Total Estimated Costs: \$ _____

CITY USE

\$25.00 Application Fee Received: 6/01/23

Application reviewed / approved by the following departments:

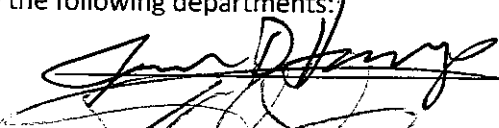
Police Chief 

DPW 

Fire Chief 

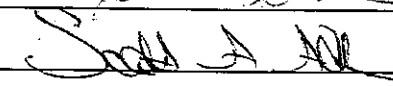
City Manager 

Approved by the City Commission on:

Memo

To: City Commission and City Manager
From: Treasurer's Office
Date: 7/12/2023
Re: Disbursements and Payroll

Listed below is the breakdown for total invoices and payroll:

Accounts Payable

Disbursements:

6/16/23-7/6/23 \$268,675.42

Encumbrances:

7/20/23 \$275,825.48

Payroll

Retiree:

7/3/23 \$48,187.98

Active:

6/8/23 \$53,316.24
6/22/23 \$56,426.16
7/6/23 \$107,322.80
7/11/23 \$1,864.25 (N. Lasecki)

Expenditure Total: \$811,618.33

Thank you

JOURNALIZED
PAID
DISBURSEMENTS - 06/16/23 TO 07/06/23

Vendor Code	Vendor name	Post Date	Invoice	Bank	Invoice Description	Gross Amount
Ref #	Address	CK Run Date	PO	Hold		Discount
Invoice Date	City/State/Zip	Disc. Date	Disc. %	Sep CK		Net Amount
Invoice Notes		Due Date		1099		
A023	AARON D ATKINSON	06/09/2023	STATEMENT	FTB	OVERTIME LUNCH MONIES WATERMAIN BREAK 6	
112604	1539 MEISNER ROAD	07/03/2023		N		10.00
06/15/2023	EAST CHINA MI, 48054	/ /	0.0000	N		0.00
		07/15/2023		N		10.00

Paid

GL NUMBER	DESCRIPTION	AMOUNT
101-441.000-722.001	OT LUNCH MONIES WATERMAIN BREAK 6/9/23	10.00

VENDOR TOTAL: 10.00

A167	ABC HOME AND COMMERCIAL SERVICES	05/20/2023	52531	FTB	SERVICE 6730 KING RD	
112523	8061 MARSH ROAD	06/16/2023		N		270.00
05/20/2023	CLAY TOWNSHIP MI, 48001-3401	/ /	0.0000	N		0.00
		06/19/2023		N		270.00

Paid

*04/23/23 - 05/20/23

GL NUMBER	DESCRIPTION	AMOUNT
101-756.000-802.000	SERVICE 6730 KING RD	270.00

A167	ABC HOME AND COMMERCIAL SERVICES	05/20/2023	52532	FTB	SERVICE EAST END ST CLAIR ST	
112522	8061 MARSH ROAD	06/16/2023		N		270.00
05/20/2023	CLAY TOWNSHIP MI, 48001-3401	/ /	0.0000	N		0.00
		06/19/2023		N		270.00

Paid

*04/23/23 - 05/20/23

GL NUMBER	DESCRIPTION	AMOUNT
101-756.000-802.000	SERVICE EAST END ST CLAIR ST	270.00

A167	ABC HOME AND COMMERCIAL SERVICES	05/20/2023	52533	FTB	SERVICE ADDRESS 134 N WATER	
112521	8061 MARSH ROAD	06/16/2023		N		145.00
05/20/2023	CLAY TOWNSHIP MI, 48001-3401	/ /	0.0000	N		0.00
		06/19/2023		N		145.00

Paid

*04/23/23 - 05/20/23

GL NUMBER	DESCRIPTION	AMOUNT
101-756.000-802.001	SERVICE ADDRESS 134 N WATER	145.00

A167	ABC HOME AND COMMERCIAL SERVICES	05/20/2023	52534	FTB	SERVICE 444 PLEASANT	
------	----------------------------------	------------	-------	-----	----------------------	--

JOURNALIZED

PAID

DISBURSEMENTS - 06/16/23 TO 07/06/23

Vendor Code	Vendor name	Post Date	Invoice	Bank	Invoice Description	Gross Amount
Ref #	Address	CK Run Date	PO	Hold		Discount
Invoice Date	City/State/Zip	Disc. Date	Disc. %	Sep CK		Net Amount
Invoice Notes		Due Date		1099		
112524	8061 MARSH ROAD	06/16/2023		N		145.00
05/20/2023	CLAY TOWNSHIP MI, 48001-3401	/ /	0.0000	N		0.00
		06/19/2023		N		145.00

Paid
*04/23/23 - 05/20/23

GL NUMBER	DESCRIPTION	AMOUNT
209-000.000-802.000	SERVICE 444 PLEASANT	145.00

A167	ABC HOME AND COMMERCIAL SERVICES	06/17/2023	52625	FTB	CLEAN AND RESTOCK 134 N WATER	
112599	8061 MARSH ROAD	07/03/2023		N		72.50
06/17/2023	CLAY TOWNSHIP MI, 48001-3401	/ /	0.0000	N		0.00
		07/17/2023		N		72.50

Paid

GL NUMBER	DESCRIPTION	AMOUNT
101-756.000-802.001	CLEAN AND RESTOCK 134 N WATER	72.50

A167	ABC HOME AND COMMERCIAL SERVICES	06/21/2023	52627	FTB	CLEAN AND RESTOCK 444 PLEASANT	
112598	8061 MARSH ROAD	07/03/2023		N		145.00
06/17/2023	CLAY TOWNSHIP MI, 48001-3401	/ /	0.0000	N		0.00
		07/17/2023		N		145.00

Paid

GL NUMBER	DESCRIPTION	AMOUNT
209-000.000-802.000	CLEAN AND RESTOCK 444 PLEASANT	145.00

A167	ABC HOME AND COMMERCIAL SERVICES	06/17/2023	52628	FTB	CLEAN RESTOCK EAST END ST CLAIR	
112601	8061 MARSH ROAD	07/03/2023		N		270.00
06/17/2023	CLAY TOWNSHIP MI, 48001-3401	/ /	0.0000	N		0.00
		07/17/2023		N		270.00

Paid

GL NUMBER	DESCRIPTION	AMOUNT
101-756.000-802.000	CLEAN RESTOCK EAST END ST CLAIR	270.00

A167	ABC HOME AND COMMERCIAL SERVICES	06/17/2023	52629	FTB	CLEAN RESTOCK 6370 KING	
112600	8061 MARSH ROAD	07/03/2023		N		270.00
06/17/2023	CLAY TOWNSHIP MI, 48001-3401	/ /	0.0000	N		0.00
		07/17/2023		N		270.00

Paid

JOURNALIZED

PAID

DISBURSEMENTS - 06/16/23 TO 07/06/23

Vendor Code	Vendor name	Post Date	Invoice	Bank	Invoice Description	Gross Amount
Ref #	Address	CK Run Date	PO	Hold		Discount
Invoice Date	City/State/Zip	Disc. Date	Disc. %	Sep CK		Net Amount
Invoice Notes		Due Date		1099		

GL NUMBER	DESCRIPTION	AMOUNT
101-756.000-802.000	CLEAN RESTOCK 6370 KING	270.00
VENDOR TOTAL:		1,587.50

C072	ADVANCE AUTO PARTS	06/07/2023	5880-423903	FTB	OIL FILTER DPW	
112537	3033 KING ROAD	06/16/2023		N		7.86
06/07/2023	EAST CHINA MI, 48054	/ /	0.0000	N		0.00
		07/07/2023		N		7.86

Paid

GL NUMBER	DESCRIPTION	AMOUNT
101-441.000-932.000	OIL FILTER DPW	7.86
VENDOR TOTAL:		7.86

A250A	AJAX MATERIALS CORPORATION	06/22/2023	285170	FTB	UPM COLD PATCH	
112611	P.O. BOX 7058	07/03/2023		N		866.25
06/12/2023	TROY MI, 48007	/ /	0.0000	N		0.00
		07/12/2023		N		866.25

Paid

GL NUMBER	DESCRIPTION	AMOUNT
203-452.000-761.000	UPM COLD PATCH	433.12
202-452.000-761.000	UPM COLD PATCH	433.13
		866.25
VENDOR TOTAL:		866.25

AA001	AMERICAN ATHLETIX	06/08/2023	7123	FTB	LITTLE LEAGUE PICNIC TABLES	
112586	PO BOX 1881	07/03/2023		N		8,000.00
06/08/2023	MUSKEGON MI, 49443	/ /	0.0000	N		0.00
		07/08/2023		N		8,000.00

Paid
*BUDGET AMEND MADE FOR THIS UP TO 8,000
6 STANDARD PICNIC 1 W ADA SPLIT SHIPPING

GL NUMBER	DESCRIPTION	AMOUNT
101-756.000-986.000	LITTLE LEAGUE PICNIC TABLES	8,000.00

JOURNALIZED

PAID

DISBURSEMENTS - 06/16/23 TO 07/06/23

Vendor Code	Vendor name	Post Date	Invoice	Bank	Invoice Description	Gross Amount
Ref #	Address	CK Run Date	PO	Hold		Discount
Invoice Date	City/State/Zip	Disc. Date	Disc. %	Sep CK		Net Amount
Invoice Notes		Due Date		1099		
VENDOR TOTAL:						8,000.00

AM01	ASCENSION MICHIGAN	05/02/2023	508226	FTB	NEW HIRE DRUG SCREENING	
112587	27351 DEQUINDRE	07/03/2023		N		204.00
05/26/2023	MADISON HEIGHTS MI, 48071	/ /	0.0000	N		0.00
		05/26/2023		N		204.00

Paid
*SCOTT ADKINS, CHRISITNA MANN, JEFF SCHMIDT

GL NUMBER	DESCRIPTION	AMOUNT
101-172.000-801.000	NEW HIRE DRUG SCREENING SCOTT ADKINS	68.00
101-253.000-801.000	NEW HIRE DRUG SCREENING CHRISTINA MANN	68.00
101-441.000-801.000	NEW HIRE DRUG SCREENING JEFF SCHMIDT	68.00
		204.00
VENDOR TOTAL:		204.00

B001	BADGER METER INC	06/28/2023	1582490	FTB	12 METERS	
112643	PO BOX 88223	07/03/2023		N		2,822.80
05/30/2023	MILWAUKEE WI, 53288-0223	/ /	0.0000	N		0.00
		06/30/2023		N		2,822.80

Paid

GL NUMBER	DESCRIPTION	AMOUNT
592-548.000-934.000	12 METERS	2,822.80
VENDOR TOTAL:		2,822.80

B170	BLUE CARE NETWORK	03/21/2023	230660027043	FTB	MNTHLY HEALTH INS PREMIUM- GRP 129721 D	
112089	PO BOX 33608	06/16/2023		N		10,530.31
03/07/2023	DETROIT MI, 48232-5608	/ /	0.0000	N		0.00
		06/16/2023		N		10,530.31

Paid

GL NUMBER	DESCRIPTION	AMOUNT
736-000.000-723.000	RETIREE HEALTH CARE-OPEB	10,530.31

B170	BLUE CARE NETWORK	07/01/2023	231570001382	FTB	MONTHLY HEALTH INSURANCE RETIREE 07/23	
112543	PO BOX 33608	07/03/2023		N		10,405.29
06/06/2023	DETROIT MI, 48232-5608	/ /	0.0000	N		0.00
		07/01/2023		N		10,405.29

JOURNALIZED

PAID

DISBURSEMENTS - 06/16/23 TO 07/06/23

Vendor Code	Vendor name	Post Date	Invoice	Bank	Invoice Description	Gross Amount
Ref #	Address	CK Run Date	PO	Hold		Discount
Invoice Date	City/State/Zip	Disc. Date	Disc. %	Sep CK		Net Amount
Invoice Notes		Due Date		1099		

Paid

GL NUMBER	DESCRIPTION	AMOUNT
736-000.000-723.000	MONTHLY HEALTH INSURANCE RETIREE 07/23	10,405.29
B170	BLUE CARE NETWORK	06/01/2023
112544	PO BOX 33608	07/03/2023
06/06/2023	DETROIT MI, 48232-5608	/ /
		0.0000
		07/01/2023
		FTB
		N
		N
		N
		N

Paid

GL NUMBER	DESCRIPTION	AMOUNT
736-000.000-723.000	ADJUSTMENT JUSTIN MCCARTNEY JUNE 2023	(461.55)

VENDOR TOTAL: 20,474.05

B015	BLUE CROSS-BLUE SHIELD OF MICH	07/01/2023	STATEMENT	FTB	MONTHLY MEDICAL ACTIVE 07/23	
112548	PO BOX 674416	07/03/2023		N		5,305.06
06/07/2023	DETROIT MI, 48267-4416	/ /	0.0000	Y		0.00
		07/03/2023		N		5,305.06

Paid

*COVERAGE PERIOD 07/01/23 - 07/31/23

GL NUMBER	DESCRIPTION	AMOUNT
101-215.000-718.001	MONTHLY MEDICAL ACTIVE 07/23	109.48
101-253.000-718.001	MONTHLY MEDICAL ACTIVE 07/23	1,082.22
101-301.000-718.001	MONTHLY MEDICAL ACTIVE 07/23	1,829.57
101-441.000-718.001	MONTHLY MEDICAL ACTIVE 07/23	1,000.57
202-450.000-718.001	MONTHLY MEDICAL ACTIVE 07/23	166.76
203-450.000-718.001	MONTHLY MEDICAL ACTIVE 07/23	250.14
592-543.000-718.001	MONTHLY MEDICAL ACTIVE 07/23	358.12
592-547.000-718.001	MONTHLY MEDICAL ACTIVE 07/23	508.20
		5,305.06

B015	BLUE CROSS-BLUE SHIELD OF MICH	07/01/2023	STATEMENT	FTB	MONTHLY INSURANCE RETIREE 07/23	
112569	PO BOX 674416	07/03/2023		N		5,331.72
06/07/2023	DETROIT MI, 48267-4416	/ /	0.0000	N		0.00
		07/03/2023		N		5,331.72

Paid

*COVERAGE PERIOD 07/01/23 - 07/31/23

JOURNALIZED

PAID

DISBURSEMENTS - 06/16/23 TO 07/06/23

Vendor Code	Vendor name	Post Date	Invoice	Bank	Invoice Description	Gross Amount
Ref #	Address	CK Run Date	PO	Hold		Discount
Invoice Date	City/State/Zip	Disc. Date	Disc. %	Sep CK		Net Amount
Invoice Notes		Due Date		1099		

GL NUMBER	DESCRIPTION	AMOUNT
736-000.000-723.000	MONTHLY INSURANCE RETIREE 07/23	5,331.72
B015	BLUE CROSS-BLUE SHIELD OF MICH	06/01/2023
112570	PO BOX 674416	07/03/2023
06/07/2023	DETROIT MI, 48267-4416	/ /
		0.0000
		07/03/2023

Paid
*MIKE ITRICH + SPOUSE

GL NUMBER	DESCRIPTION	AMOUNT
736-000.000-723.000	RETIREE ADJUSTMENT 06/23	1,469.68
B015	BLUE CROSS-BLUE SHIELD OF MICH	05/18/2023
112571	PO BOX 674416	07/03/2023
06/07/2023	DETROIT MI, 48267-4416	/ /
		0.0000
		07/03/2023

Paid
*MIKE ITRICH + SPOUSE

GL NUMBER	DESCRIPTION	AMOUNT
736-000.000-723.000	RETIREE ADJUSTMENT 05/23	636.86

VENDOR TOTAL: 12,743.32

B131	BLUE WATER FUEL MANAGEMENT	06/30/2023	10725	FTB	FUEL	
112689	36065 WATER ST	07/06/2023		N		1,220.78
06/30/2023	RICHMOND MI, 48062-0430	/ /	0.0000	N		0.00
		07/15/2023		N		1,220.78

Paid

GL NUMBER	DESCRIPTION	AMOUNT
101-301.000-759.000	GASOLINE	1,220.78

VENDOR TOTAL: 1,220.78

A275	BRIAN ATHERTON	06/09/2023	STATEMENT	FTB	OVERTIME LUNCH MONIES WATERMAIN BREAK 6	
112603		07/03/2023		N		10.00
06/15/2023	630 SUMMER STREET	/ /	0.0000	N		0.00
	ALGONAC MI, 48001	07/15/2023		N		10.00

Paid

JOURNALIZED

PAID

DISBURSEMENTS - 06/16/23 TO 07/06/23

Vendor Code	Vendor name	Post Date	Invoice	Bank	Invoice Description	Gross Amount
Ref #	Address	CK Run Date	PO	Hold		Discount
Invoice Date	City/State/Zip	Disc. Date	Disc. %	Sep CK		Net Amount
Invoice Notes		Due Date		1099		

GL NUMBER	DESCRIPTION	AMOUNT
101-441.000-722.001	OT LUNCH MONIES WATERMAIN BREAK 6/9/23	10.00
VENDOR TOTAL:		10.00

CM01	CHRISTINA MANN	06/27/2023	STATEMENT	FTB	MILEAGE REIMBURSEMENT	
112640	409 WALNUT	07/03/2023		N		68.12
06/30/2023	EAST CHINA MI, 48054	/ /	0.0000	N		0.00
		07/08/2023		N		68.12
Paid						
*BANK TRIPS 4/13-6/28/23						
104 TOTAL MILES @.655						

GL NUMBER	DESCRIPTION	AMOUNT
101-253.000-861.000	MILEAGE REIMBURSEMENT	68.12
VENDOR TOTAL:		68.12

C252	COMCAST	07/12/2023	STATEMENT	FTB	514 S PARKER ST DPW	
112686	PO BOX 7500	07/06/2023		N		222.66
06/28/2023	SOUTHEASTERN PA, 19398-7500	/ /	0.0000	N		0.00
		07/19/2023		N		222.66
Paid						
*7/12-8/11/2023						

GL NUMBER	DESCRIPTION	AMOUNT
101-441.000-850.000	514 S PARKER ST	222.66

C252	COMCAST	07/14/2023	STATEMENT	FTB	601 WARD ST LITTLE LEAGUE PARK	
112687	PO BOX 7500	07/06/2023		N		78.16
07/01/2023	SOUTHEASTERN PA, 19398-7500	/ /	0.0000	N		0.00
		07/22/2023		N		78.16
Paid						
*7/14-8/13/23						

GL NUMBER	DESCRIPTION	AMOUNT
101-756.000-850.000	601 WARD ST LITTLE LEAGUE PARK	78.16

C252	COMCAST	06/19/2023	STATEMENT	FTB	304 S BELLE RIVER AVE	
112588	PO BOX 7500	07/03/2023		N		65.60
06/17/2023	SOUTHEASTERN PA, 19398-7500	/ /	0.0000	Y		0.00

User: POSEY

EXP CHECK RUN DATES 06/16/2023 - 07/06/2023

DB: Marine City

JOURNALIZED

PAID

DISBURSEMENTS - 06/16/23 TO 07/06/23

Vendor Code	Vendor name	Post Date	Invoice	Bank	Invoice Description	Gross Amount
Ref #	Address	CK Run Date	PO	Hold		Discount
Invoice Date	City/State/Zip	Disc. Date	Disc. %	Sep CK		Net Amount
Invoice Notes		Due Date		1099		
		07/08/2023		N		65.60

Paid
*7/1-7/30/23

GL NUMBER	DESCRIPTION	AMOUNT
592-546.000-850.000	304 S BELLE RIVER AVE	65.60
C252	COMCAST	06/19/2023
112589	PO BOX 7500	07/03/2023
06/17/2023	SOUTHEASTERN PA, 19398-7500	/ /
		0.0000
		07/08/2023
		FTB 6160 KING RD
		N 65.60
		Y 0.00
		N 65.60

Paid
*7-1/7-30-23

GL NUMBER	DESCRIPTION	AMOUNT
592-546.000-850.000	6160 KING RD	65.60
C252	COMCAST	07/04/2023
112628	PO BOX 7500	07/03/2023
06/21/2023	SOUTHEASTERN PA, 19398-7500	/ /
		0.0000
		07/12/2023
		FTB 1696 S PARKER
		N 206.71
		Y 0.00
		N 206.71

Paid
*7/4-8/3/23

GL NUMBER	DESCRIPTION	AMOUNT
592-545.000-850.000	1696 S PARKER	206.71
C252	COMCAST	07/06/2023
112629	PO BOX 7500	07/03/2023
06/23/2023	SOUTHEASTERN PA, 19398-7500	/ /
		0.0000
		07/14/2023
		FTB 405 S MAIN MUSEUM
		N 133.44
		N 0.00
		N 133.44

Paid
*7/6-8/5/23

GL NUMBER	DESCRIPTION	AMOUNT
101-804.000-850.000	405 S MAIN MUSEUM	133.44
C252	COMCAST	07/07/2023
112630	PO BOX 7500	07/03/2023
06/24/2023	SOUTHEASTERN PA, 19398-7500	/ /
		0.0000
		07/15/2023
		FTB 300 S PARKER LIBRARY
		N 127.23
		N 0.00
		N 127.23

JOURNALIZED

PAID

DISBURSEMENTS - 06/16/23 TO 07/06/23

Vendor Code	Vendor name	Post Date	Invoice	Bank	Invoice Description	Gross Amount
Ref #	Address	CK Run Date	PO	Hold		Discount
Invoice Date	City/State/Zip	Disc. Date	Disc. %	Sep CK		Net Amount
Invoice Notes		Due Date		1099		

Paid
 *7/7-8/6/23

GL NUMBER	DESCRIPTION	AMOUNT
101-790.000-850.000	300 S PARKER LIBRARY	127.23
C252	COMCAST	06/14/2023
112555	PO BOX 7500	06/16/2023
06/10/2023	SOUTHEASTERN PA, 19398-7500	/ /
		0.0000
		07/01/2023
		FTB
		MONTHLY CHARGES 260 S PARKER
		N
		206.31
		N
		0.00
		206.31

Paid
 *6/14-7/13/23

GL NUMBER	DESCRIPTION	AMOUNT
101-172.000-850.000	MONTHLY CHARGES 260 S PARKER	34.39
101-257.000-850.000	MONTHLY CHARGES 260 S PARKER	34.39
101-215.000-850.000	MONTHLY CHARGES 260 S PARKER	34.39
101-253.000-850.000	MONTHLY CHARGES 260 S PARKER	34.39
101-371.000-850.000	MONTHLY CHARGES 260 S PARKER	34.39
592-543.000-850.000	MONTHLY CHARGES 260 S PARKER	17.18
592-547.000-850.000	MONTHLY CHARGES 260 S PARKER	17.18
		<u>206.31</u>

C252	COMCAST	06/20/2023	STATEMENT	FTB	MONTHLY CHARGES 375 S PARKER	
112556	PO BOX 7500	06/16/2023		N		420.25
06/07/2023	SOUTHEASTERN PA, 19398-7500	/ /	0.0000	N		0.00
		06/28/2023		N		420.25

Paid
 *6/20-7/19/23

GL NUMBER	DESCRIPTION	AMOUNT
101-301.000-850.000	MONTHLY CHARGES 375 S PARKER	420.25

C252	COMCAST	06/21/2023	STATEMENT	FTB	MONTHLY CHARGES 229 S WATER	
112557	PO BOX 7500	06/16/2023		N		177.56
06/08/2023	SOUTHEASTERN PA, 19398-7500	/ /	0.0000	N		0.00
		06/29/2023		N		177.56

Paid
 *6/21-7/20/23

GL NUMBER	DESCRIPTION	AMOUNT
592-549.000-850.000	MONTHLY CHARGES 229 S WATER	177.56

JOURNALIZED

PAID

DISBURSEMENTS - 06/16/23 TO 07/06/23

Vendor Code	Vendor name	Post Date	Invoice	Bank	Invoice Description	Gross Amount
Ref #	Address	CK Run Date	PO	Hold		Discount
Invoice Date	City/State/Zip	Disc. Date	Disc. %	Sep CK		Net Amount
Invoice Notes		Due Date		1099		

VENDOR TOTAL: 1,703.52

D159	DAVIS LISTMAN PLLC	06/27/2023	10821	FTB	PROFESSIONAL SERVICES MAY 2023	
112641	10 S. MAIN STREET, SUITE 401	07/03/2023		N		3,258.50
05/31/2023	MOUNT CLEMENS MI, 48043	/ /	0.0000	N		0.00
		06/15/2023		Y		3,258.50

Paid

GL NUMBER	DESCRIPTION	AMOUNT
101-266.000-801.000	PROFESSIONAL SERVICES MAY 2023	3,258.50

D159	DAVIS LISTMAN PLLC	06/30/2023	10868	FTB	PROFESSIONAL SERVICES JUNE PROSECUTION	
112688	10 S. MAIN STREET, SUITE 401	07/06/2023		N		2,170.27
06/30/2023	MOUNT CLEMENS MI, 48043	/ /	0.0000	N		0.00
		07/15/2023		Y		2,170.27

Paid

GL NUMBER	DESCRIPTION	AMOUNT
101-266.000-801.000	PROFESSIONAL SERVICES	2,170.27

VENDOR TOTAL: 5,428.77

DS01	DENNIS SUMMERVILLE	06/14/2023	STATEMENT	FTB	SIDEWALK INCENTIVE PROGRAM	
112597	312 WEST BLVD	07/03/2023		N		454.75
06/14/2023	MARINE CITY MI, 48039	/ /	0.0000	N		0.00
		07/03/2023		N		454.75

Paid

GL NUMBER	DESCRIPTION	AMOUNT
101-271.000-752.100	SIDEWALK INCENTIVE PROGRAM	454.75

VENDOR TOTAL: 454.75

D008	DTE ENERGY	06/12/2023	STATEMENT	FTB	MONTHLY CHARGES 1698 S PARKER	
112552	PO BOX 740786	06/16/2023		N		7,041.32
06/12/2023	CINCINNATI OH, 45274-0786	/ /	0.0000	N		0.00
		07/05/2023		N		7,041.32

Paid

*5/11-6/12/23

07/12/2023 03:38 PM
 User: POSEY
 DB: Marine City

INVOICE APPROVAL BY INVOICE REPORT FOR CITY OF MARINE CITY
 EXP CHECK RUN DATES 06/16/2023 - 07/06/2023

JOURNALIZED
 PAID

DISBURSEMENTS - 06/16/23 TO 07/06/23

Vendor Code	Vendor name	Post Date	Invoice	Bank	Invoice Description	Gross Amount
Ref #	Address	CK Run Date	PO	Hold		Discount
Invoice Date	City/State/Zip	Disc. Date	Disc. %	Sep CK		Net Amount
Invoice Notes		Due Date		1099		

GL NUMBER	DESCRIPTION	AMOUNT				
592-545.000-920.000	MONTHLY CHARGES 1698 S PARKER	7,041.32				
D008	DTE ENERGY	05/01/2023	STATEMENT	FTB	STREET LIGHTING 05/23	
112553	PO BOX 740786	06/16/2023		N		7,800.64
05/01/2023	CINCINNATI OH, 45274-0786	/ /	0.0000	N		0.00
		07/03/2023		N		7,800.64

Paid
 *5/1-5/31/23

GL NUMBER	DESCRIPTION	AMOUNT				
101-448.000-926.000	STREET LIGHTING 05/23	7,800.64				
D008	DTE ENERGY	04/30/2023	STATEMENT	FTB	325 S MARINE	
112554	PO BOX 740786	06/16/2023		N		21.14
06/08/2023	CINCINNATI OH, 45274-0786	/ /	0.0000	N		0.00
		06/30/2023		N		21.14

Paid
 *4/20-4/30/23
 MARINA SITE

GL NUMBER	DESCRIPTION	AMOUNT				
101-756.000-920.002	325 S MARINE	21.14				
D008	DTE ENERGY	06/21/2023	STATEMENT	FTB	304 S BELLE RIVER AVE	
112631	PO BOX 740786	07/03/2023		N		837.34
06/22/2023	CINCINNATI OH, 45274-0786	/ /	0.0000	N		0.00
		07/14/2023		N		837.34

Paid
 *5/20-6/21/23

GL NUMBER	DESCRIPTION	AMOUNT				
592-546.000-920.000	304 S BELLE RIVER AVE	837.34				
D008	DTE ENERGY	06/21/2023	STATEMENT	FTB	444 PLEASANT ST	
112632	PO BOX 740786	07/03/2023		N		16.52
06/22/2023	CINCINNATI OH, 45274-0786	/ /	0.0000	N		0.00
		07/14/2023		N		16.52

Paid
 *5/20-6/21/23

GL NUMBER	DESCRIPTION	AMOUNT
-----------	-------------	--------

07/12/2023 03:38 PM
 User: POSEY
 DB: Marine City

INVOICE APPROVAL BY INVOICE REPORT FOR CITY OF MARINE CITY
 EXP CHECK RUN DATES 06/16/2023 - 07/06/2023

JOURNALIZED
 PAID
 DISBURSEMENTS - 06/16/23 TO 07/06/23

Vendor Code	Vendor name	Post Date	Invoice	Bank	Invoice Description	Gross Amount
Ref #	Address	CK Run Date	PO	Hold		Discount
Invoice Date	City/State/Zip	Disc. Date	Disc. %	Sep CK		Net Amount
Invoice Notes		Due Date		1099		
209-000.000-920.000	444 PLEASANT ST					16.52
D008	DTE ENERGY	06/21/2023	STATEMENT	FTB	514 S PARKER ST	
112633	PO BOX 740786	07/03/2023		N		402.09
06/22/2023	CINCINNATI OH, 45274-0786	/ /	0.0000	N		0.00
		07/14/2023		N		402.09
Paid						
*5/20-6/21/23						
GL NUMBER	DESCRIPTION				AMOUNT	
101-441.000-920.000	514 S PARKER ST				402.09	
D008	DTE ENERGY	06/21/2023	STATEMENT	FTB	375 S PARKER ST	
112634	PO BOX 740786	07/03/2023		N		255.16
06/22/2023	CINCINNATI OH, 45274-0786	/ /	0.0000	N		0.00
		07/14/2023		N		255.16
Paid						
*5/20-6/21/23						
GL NUMBER	DESCRIPTION				AMOUNT	
101-301.000-920.000	375 S PARKER ST				255.16	
D008	DTE ENERGY	06/21/2023	STATEMENT	FTB	300 S PARKER ST	
112635	PO BOX 740786	07/03/2023		N		649.85
06/22/2023	CINCINNATI OH, 45274-0786	/ /	0.0000	N		0.00
		07/14/2023		N		649.85
Paid						
*5/20-6/21/23						
GL NUMBER	DESCRIPTION				AMOUNT	
101-790.000-920.000	300 S PARKER ST				649.85	
D008	DTE ENERGY	06/21/2023	STATEMENT	FTB	260 S PARKER (SUITE A)	
112636	PO BOX 740786	07/03/2023		N		448.26
06/22/2023	CINCINNATI OH, 45274-0786	/ /	0.0000	N		0.00
		07/14/2023		N		448.26
Paid						
*5/20-6/21-23						
GL NUMBER	DESCRIPTION				AMOUNT	
101-265.000-920.000	260 S PARKER (SUITE A)				448.26	

JOURNALIZED

PAID

DISBURSEMENTS - 06/16/23 TO 07/06/23

Vendor Code	Vendor name	Post Date	Invoice	Bank	Invoice Description	Gross Amount
Ref #	Address	CK Run Date	PO	Hold		Discount
Invoice Date	City/State/Zip	Disc. Date	Disc. %	Sep CK		Net Amount
Invoice Notes		Due Date		1099		
D008	DTE ENERGY	06/15/2023	STATEMENT	FTB	6160 KING RD	
112606	PO BOX 740786	07/03/2023		N		25.04
06/16/2023	CINCINNATI OH, 45274-0786	/ /	0.0000	N		0.00
		07/10/2023		N		25.04

Paid
*5/17-6/15/23

GL NUMBER	DESCRIPTION	AMOUNT
592-546.000-920.000	6160 KING RD	25.04

D008	DTE ENERGY	06/15/2023	STATEMENT	FTB	6370 KING ROAD (WATER TOWER)	
112607	PO BOX 740786	07/03/2023		N		87.85
06/16/2023	CINCINNATI OH, 45274-0786	/ /	0.0000	N		0.00
		07/10/2023		N		87.85

Paid

GL NUMBER	DESCRIPTION	AMOUNT
592-549.000-920.000	6370 KING ROAD (WATER TOWER)	87.85

D008	DTE ENERGY	06/15/2023	STATEMENT	FTB	6370 KING RD (PARKS)	
112608	PO BOX 740786	07/03/2023		N		133.43
06/16/2023	CINCINNATI OH, 45274-0786	/ /	0.0000	N		0.00
		07/10/2023		N		133.43

Paid
*5/17-6/15/23

GL NUMBER	DESCRIPTION	AMOUNT
101-756.000-920.000	6370 KING RD (PARKS)	133.43

D008	DTE ENERGY	06/21/2023	STATEMENT	FTB	260 S PARKER B	
112655	PO BOX 740786	07/03/2023		N		50.38
06/26/2023	CINCINNATI OH, 45274-0786	/ /	0.0000	N		0.00
		07/18/2023		N		50.38

Paid
*5/20-6/21/23

GL NUMBER	DESCRIPTION	AMOUNT
101-265.000-920.000	260 S PARKER B	50.38

D008	DTE ENERGY	06/21/2023	STATEMENT	FTB	424 PLEASANT	
112656	PO BOX 740786	07/03/2023		N		14.89
06/26/2023	CINCINNATI OH, 45274-0786	/ /	0.0000	N		0.00

JOURNALIZED

PAID

DISBURSEMENTS - 06/16/23 TO 07/06/23

Vendor Code	Vendor name	Post Date	Invoice	Bank	Invoice Description	Gross Amount
Ref #	Address	CK Run Date	PO	Hold		Discount
Invoice Date	City/State/Zip	Disc. Date	Disc. %	Sep CK		Net Amount
Invoice Notes		Due Date		1099		
		06/26/2023		N		14.89

Paid
*5/20-6/21/23

GL NUMBER	DESCRIPTION	AMOUNT
209-000.000-920.000	424 PLEASANT	14.89

D008	DTE ENERGY	06/22/2023	STATEMENT	FTB	231 S WATER ST	
112614	PO BOX 740786	06/22/2023		N		3,101.24
06/21/2023	CINCINNATI OH, 45274-0786	/ /	0.0000	N		0.00
		07/13/2023		N		3,101.24

Paid
*5/19-6/19/23

GL NUMBER	DESCRIPTION	AMOUNT
592-549.000-920.000	231 S WATER ST	3,101.24

D008	DTE ENERGY	06/21/2023	STATEMENT	FTB	200 N WATER ST	
112615	PO BOX 740786	06/22/2023		N		18.33
06/21/2023	CINCINNATI OH, 45274-0786	/ /	0.0000	N		0.00
		07/13/2023		N		18.33

Paid
*5/19-6/19/23

GL NUMBER	DESCRIPTION	AMOUNT
101-756.000-920.000	200 N WATER ST	18.33

D008	DTE ENERGY	06/21/2023	STATEMENT	FTB	300 BROADWAY ST	
112616	PO BOX 740786	06/22/2023		N		80.81
06/21/2023	CINCINNATI OH, 45274-0786	/ /	0.0000	N		0.00
		07/13/2023		N		80.81

Paid
*5/19-6/19/23

GL NUMBER	DESCRIPTION	AMOUNT
101-265.000-920.000	300 BROADWAY ST	80.81

D008	DTE ENERGY	06/21/2023	STATEMENT	FTB	405 S MAIN ST	
112617	PO BOX 740786	06/22/2023		N		60.84
06/21/2023	CINCINNATI OH, 45274-0786	/ /	0.0000	N		0.00
		07/13/2023		N		60.84

JOURNALIZED

PAID

DISBURSEMENTS - 06/16/23 TO 07/06/23

Vendor Code	Vendor name	Post Date	Invoice	Bank	Invoice Description	Gross Amount
Ref #	Address	CK Run Date	PO	Hold		Discount
Invoice Date	City/State/Zip	Disc. Date	Disc. %	Sep CK		Net Amount
Invoice Notes		Due Date		1099		

Paid
*5/19-6/19/23

GL NUMBER	DESCRIPTION	AMOUNT
101-804.000-920.000	405 S MAIN ST	60.84
D008	DTE ENERGY	06/21/2023
112618	PO BOX 740786	06/22/2023
06/21/2023	CINCINNATI OH, 45274-0786	/ /
		0.0000
		07/13/2023
		FTB 401 S WATER ST
		N 25.03
		N 0.00
		N 25.03

Paid

GL NUMBER	DESCRIPTION	AMOUNT
101-756.000-920.000	401 S WATER ST	25.03
D008	DTE ENERGY	06/21/2023
112619	PO BOX 740786	06/22/2023
06/21/2023	CINCINNATI OH, 45274-0786	/ /
		0.0000
		07/13/2023
		FTB 477 S WATER ST
		N 35.39
		N 0.00
		N 35.39

Paid
*5/19-6/19/23

GL NUMBER	DESCRIPTION	AMOUNT
101-756.000-920.000	477 S WATER ST	35.39
D008	DTE ENERGY	06/21/2023
112620	PO BOX 740786	06/22/2023
06/21/2023	CINCINNATI OH, 45274-0786	/ /
		0.0000
		07/13/2023
		FTB 720 S BELLE RIVER AVE
		N 57.99
		N 0.00
		N 57.99

Paid
*5/19-6/19/23

GL NUMBER	DESCRIPTION	AMOUNT
202-453.000-920.000	720 S. BELLE RIVER AVE	57.99
D008	DTE ENERGY	06/21/2023
112621	PO BOX 740786	06/22/2023
06/21/2023	CINCINNATI OH, 45274-0786	/ /
		0.0000
		07/13/2023
		FTB 134 N WATER PAVILION
		N 54.19
		N 0.00
		N 54.19

Paid
*5/19-6/19/23

JOURNALIZED

PAID

DISBURSEMENTS - 06/16/23 TO 07/06/23

Vendor Code	Vendor name	Post Date	Invoice	Bank	Invoice Description	Gross Amount
Ref #	Address	CK Run Date	PO	Hold		Discount
Invoice Date	City/State/Zip	Disc. Date	Disc. %	Sep CK		Net Amount
Invoice Notes		Due Date		1099		

GL NUMBER	DESCRIPTION	AMOUNT				
101-756.000-920.001	134 N WATER PAVILION	54.19				
D008	DTE ENERGY	06/21/2023	STATEMENT	FTB	100 BROADWAY ST	
112622	PO BOX 740786	06/22/2023		N		34.22
06/21/2023	CINCINNATI OH, 45274-0786	/ /	0.0000	N		0.00
		07/13/2023		N		34.22

Paid
*5/19-6/19/23

GL NUMBER	DESCRIPTION	AMOUNT				
101-756.000-920.000	100 BROADWAY ST	34.22				
D008	DTE ENERGY	06/21/2023	STATEMENT	FTB	305 S WATER ST	
112623	PO BOX 740786	06/22/2023		N		54.86
06/21/2023	CINCINNATI OH, 45274-0786	/ /	0.0000	N		0.00
		07/13/2023		N		54.86

Paid
*5/19-6/19/23

GL NUMBER	DESCRIPTION	AMOUNT
101-756.000-920.000	305 S WATER ST	54.86

VENDOR TOTAL: 21,306.81

D050	DYCK SECURITY SERVICES	05/26/2023	S22349	FTB	REMOVE USER - CITY OFFICES	
112510	2425 MINNIE STREET	06/16/2023		N		25.00
05/26/2023	PORT HURON MI, 48060-4733	/ /	0.0000	N		0.00
		06/25/2023		N		25.00

Paid

GL NUMBER	DESCRIPTION	AMOUNT				
101-265.000-802.000	REMOVE USER - CITY OFFICES	25.00				
D050	DYCK SECURITY SERVICES	06/16/2023	S22422	FTB	ADD USER KATY POSEY	
112625	2425 MINNIE STREET	07/03/2023		N		25.00
06/18/2023	PORT HURON MI, 48060-4733	/ /	0.0000	N		0.00
		07/18/2023		N		25.00

Paid

GL NUMBER	DESCRIPTION	AMOUNT
101-265.000-802.000	ADD USER KATY POSEY	25.00

JOURNALIZED

PAID
 DISBURSEMENTS - 06/16/23 TO 07/06/23

Vendor Code	Vendor name	Post Date	Invoice	Bank	Invoice Description	Gross Amount
Ref #	Address	CK Run Date	PO	Hold		Discount
Invoice Date	City/State/Zip	Disc. Date	Disc. %	Sep CK		Net Amount
Invoice Notes		Due Date		1099		

VENDOR TOTAL: 50.00

E070	EDW C LEVY CO	06/09/2023	2801386	FTB	23A LS MAR	
112678	ACCOUNTS RECEIVABLE	07/06/2023		N		97.78
	26268 NETWORK PLACE					
06/09/2023	CHICAGO IL, 60673-1262	/ /	0.0000	N		0.00
		07/09/2023		N		97.78

Paid

GL NUMBER	DESCRIPTION	AMOUNT
203-452.000-761.000	23A LS MAR	97.78

VENDOR TOTAL: 97.78

FV150	F & V OPERATIONS RESOURCE MGMT	06/30/2023	6059	FTB	SERVICES JUNE 2023	
112536	2960 LUCERNE DRIVE SE SUITE 100	06/16/2023		N		34,416.24
06/01/2023	GRAND RAPIDS MI, 49546	/ /	0.0000	N		0.00
		06/30/2023		N		34,416.24

Paid

GL NUMBER	DESCRIPTION	AMOUNT
592-549.000-802.000	SERVICES JUNE 2023	17,208.12
592-545.000-802.000	SERVICES JUNE 2023	17,208.12

34,416.24

FV150	F & V OPERATIONS RESOURCE MGMT	04/29/2023	6068	FTB	APRIL OUT OF SCOPE SERV 4/2023	
112535	2960 LUCERNE DRIVE SE SUITE 100	06/16/2023		N		1,457.59
05/26/2023	GRAND RAPIDS MI, 49546	/ /	0.0000	N		0.00
		06/26/2023		N		1,457.59

Paid

GL NUMBER	DESCRIPTION	AMOUNT
592-545.000-802.000	APRIL OUT OF SCOPE SERV 4/2023	1,037.59
592-546.000-802.000	APRIL OUT OF SCOPE SERV 4/2023	120.00
592-549.000-802.000	APRIL OUT OF SCOPE SERV 4/2023	300.00

1,457.59

FV150	F & V OPERATIONS RESOURCE MGMT	06/26/2023	6087	FTB	WATER PLANT CONTRACTUAL SERVICES APRIL	
112627	2960 LUCERNE DRIVE SE SUITE 100	07/03/2023		N		535.72

JOURNALIZED

PAID

DISBURSEMENTS - 06/16/23 TO 07/06/23

Vendor Code	Vendor name	Post Date	Invoice	Bank	Invoice Description	Gross Amount
Ref #	Address	CK Run Date	PO	Hold		Discount
Invoice Date	City/State/Zip	Disc. Date	Disc. %	Sep CK		Net Amount
Invoice Notes		Due Date		1099		
06/16/2023	GRAND RAPIDS MI, 49546	/ /	0.0000	N		0.00
		07/16/2023		N		535.72

Paid

GL NUMBER	DESCRIPTION	AMOUNT
592-549.000-802.000	CONTRACTUAL SERVICES	267.86
592-545.000-802.000	CONTRACTUAL SERVICES	267.86
		<u>535.72</u>

VENDOR TOTAL: 36,409.55

F120	FGM SOLUTIONS, INC.	05/16/2023	1577	FTB	CALIBRATION FLOWMETERS WATER PLANT	
112531	110 HURON BOULEVARD	06/16/2023		N		850.00
	SUITE A					
05/30/2023	MARYSVILLE MI, 48040	/ /	0.0000	N		0.00
		06/30/2023		N		850.00

Paid

GL NUMBER	DESCRIPTION	AMOUNT
592-549.000-802.000	CALIBRATION FLOWMETERS WATER PLANT	850.00

F120	FGM SOLUTIONS, INC.	05/18/2023	1578	FTB	CALIBRATION FLOWMETERS WWTP	
112530	110 HURON BOULEVARD	06/16/2023		N		2,550.00
	SUITE A					
05/30/2023	MARYSVILLE MI, 48040	/ /	0.0000	N		0.00
		06/30/2023		N		2,550.00

Paid

GL NUMBER	DESCRIPTION	AMOUNT
592-545.000-802.000	CALIBRATION FLOWMETERS WWTP	2,550.00

F120	FGM SOLUTIONS, INC.	05/18/2023	1579	FTB	CALIBRATION FLOWMETER PUMP STN	
112532	110 HURON BOULEVARD	06/16/2023		N		425.00
	SUITE A					
05/30/2023	MARYSVILLE MI, 48040	/ /	0.0000	N		0.00
		06/30/2023		N		425.00

Paid

GL NUMBER	DESCRIPTION	AMOUNT
592-546.000-802.000	CALIBRATION FLOWMETER PUMP STN	425.00

JOURNALIZED

PAID

DISBURSEMENTS - 06/16/23 TO 07/06/23

Vendor Code	Vendor name	Post Date	Invoice	Bank	Invoice Description	Gross Amount
Ref #	Address	CK Run Date	PO	Hold		Discount
Invoice Date	City/State/Zip	Disc. Date	Disc. %	Sep CK		Net Amount
Invoice Notes		Due Date		1099		

F120	FGM SOLUTIONS, INC.	05/18/2023	1582	FTB	CALIBRATION VERIFICATION WWTP	
112612	110 HURON BOULEVARD	07/03/2023		N		425.00
	SUITE A	/ /	0.0000	N		0.00
05/18/2023	MARYSVILLE MI, 48040	07/17/2023		N		425.00

Paid

GL NUMBER	DESCRIPTION	AMOUNT
592-545.000-802.000	CALIBRATION VERIFICATION WWTP	425.00

VENDOR TOTAL: 4,250.00

F013	FIFER INVESTIGATIONS	05/25/2023	2545	FTB	BACKGROUND JEFF SCHMIDT	
112538	31564 SCHOOLCRAFT RD	06/16/2023		N		950.00
05/25/2023	LIVONIA MI, 48150	/ /	0.0000	N		0.00
		06/24/2023		N		950.00

Paid

GL NUMBER	DESCRIPTION	AMOUNT
101-441.000-801.000	BACKGROUND JEFF SCHMIDT	950.00

F013	FIFER INVESTIGATIONS	06/14/2023	2565	FTB	BACKGROUND INVESTIGATION KATY POSEY	
112551	31564 SCHOOLCRAFT RD	06/16/2023		N		950.00
06/14/2023	LIVONIA MI, 48150	/ /	0.0000	N		0.00
		07/14/2023		N		950.00

Paid

GL NUMBER	DESCRIPTION	AMOUNT
101-253.000-801.000	BACKGROUND INVESTIGATION KATY POSEY	950.00

VENDOR TOTAL: 1,900.00

V024	FLAGSHIP-VISA	05/11/2023	STATEMENT	FTB	POLARIS STABILIZER BAR-DPW	
112575	3910 LAPEER RD	06/16/2023		N		129.99
06/02/2023	PORT HURON MI, 48060-2402	/ /	0.0000	N		0.00
		06/27/2023		N		129.99

Paid

GL NUMBER	DESCRIPTION	AMOUNT
101-441.000-931.003	POLARIS STABILIZER BAR-DPW	129.99

JOURNALIZED

PAID

DISBURSEMENTS - 06/16/23 TO 07/06/23

Vendor Code	Vendor name	Post Date	Invoice	Bank	Invoice Description	Gross Amount
Ref #	Address	CK Run Date	PO	Hold		Discount
Invoice Date	City/State/Zip	Disc. Date	Disc. %	Sep CK		Net Amount
Invoice Notes		Due Date		1099		
V024	FLAGSHIP-VISA	05/11/2023	STATEMENT	FTB	SPRINKLER SYSTEM SUPPLIES	
112576	3910 LAPEER RD	06/16/2023		N		69.90
06/02/2023	PORT HURON MI, 48060-2402	/ /	0.0000	N		0.00
		06/27/2023		N		69.90

Paid

GL NUMBER	DESCRIPTION	AMOUNT
101-756.000-752.000	SPRINKLER SYSTEM SUPPLIES	69.90

Vendor Code	Vendor name	Post Date	Invoice	Bank	Invoice Description	Gross Amount
Ref #	Address	CK Run Date	PO	Hold		Discount
Invoice Date	City/State/Zip	Disc. Date	Disc. %	Sep CK		Net Amount
Invoice Notes		Due Date		1099		
V024	FLAGSHIP-VISA	05/15/2023	STATEMENT	FTB	POLARIS REPAIR SUPPLIES	
112577	3910 LAPEER RD	06/16/2023		N		109.14
05/15/2023	PORT HURON MI, 48060-2402	/ /	0.0000	N		0.00
		06/27/2023		N		109.14

Paid

GL NUMBER	DESCRIPTION	AMOUNT
101-441.000-931.003	POLARIS REPAIR SUPPLIES	109.14

Vendor Code	Vendor name	Post Date	Invoice	Bank	Invoice Description	Gross Amount
Ref #	Address	CK Run Date	PO	Hold		Discount
Invoice Date	City/State/Zip	Disc. Date	Disc. %	Sep CK		Net Amount
Invoice Notes		Due Date		1099		
V024	FLAGSHIP-VISA	05/15/2023	STATEMENT	FTB	SOAP/PAPER/MISC SUPPLIES	
112578	3910 LAPEER RD	06/16/2023		N		64.62
06/02/2023	PORT HURON MI, 48060-2402	/ /	0.0000	N		0.00
		06/27/2023		N		64.62

Paid

GL NUMBER	DESCRIPTION	AMOUNT
101-265.000-752.000	SOAP/PAPER/MISC SUPPLIES	64.62

Vendor Code	Vendor name	Post Date	Invoice	Bank	Invoice Description	Gross Amount
Ref #	Address	CK Run Date	PO	Hold		Discount
Invoice Date	City/State/Zip	Disc. Date	Disc. %	Sep CK		Net Amount
Invoice Notes		Due Date		1099		
V024	FLAGSHIP-VISA	05/16/2023	STATEMENT	FTB	EXPANDABLE FOLDER/HIGHLIGHTERS	
112579	3910 LAPEER RD	06/16/2023		N		38.34
06/02/2023	PORT HURON MI, 48060-2402	/ /	0.0000	N		0.00
		06/27/2023		N		38.34

Paid

GL NUMBER	DESCRIPTION	AMOUNT
101-253.000-755.000	EXPANDABLE FOLDER/HIGHLIGHTERS	38.34

Vendor Code	Vendor name	Post Date	Invoice	Bank	Invoice Description	Gross Amount
Ref #	Address	CK Run Date	PO	Hold		Discount
Invoice Date	City/State/Zip	Disc. Date	Disc. %	Sep CK		Net Amount
Invoice Notes		Due Date		1099		
V024	FLAGSHIP-VISA	05/04/2023	STATEMENT	FTB	PAPER TOWEL-PD	
112580	3910 LAPEER RD	06/16/2023		N		80.46
06/02/2023	PORT HURON MI, 48060-2402	/ /	0.0000	N		0.00
		06/27/2023		N		80.46

Paid

JOURNALIZED
PAID
DISBURSEMENTS - 06/16/23 TO 07/06/23

Vendor Code	Vendor name	Post Date	Invoice	Bank	Invoice Description	Gross Amount
Ref #	Address	CK Run Date	PO	Hold		Discount
Invoice Date	City/State/Zip	Disc. Date	Disc. %	Sep CK		Net Amount
Invoice Notes		Due Date		1099		

GL NUMBER	DESCRIPTION	AMOUNT				
101-301.000-752.000	PAPER TOWEL-PD	80.46				
V024	FLAGSHIP-VISA	05/04/2023	STATEMENT	FTB	BATTERIES/PAPERCLIPS-PD	
112581	3910 LAPEER RD	06/16/2023		N		28.18
06/02/2023	PORT HURON MI, 48060-2402	/ /	0.0000	N		0.00
		06/27/2023		N		28.18

Paid

GL NUMBER	DESCRIPTION	AMOUNT
101-301.000-752.000	BATTERIES	16.49
101-301.000-755.000	PAPERCLIPS	11.69
		<u>28.18</u>

V024	FLAGSHIP-VISA	05/16/2023	STATEMENT	FTB	COPY PAPER-PD/CH	
112582	3910 LAPEER RD	06/16/2023		N		303.92
06/02/2023	PORT HURON MI, 48060-2402	/ /	0.0000	N		0.00
		06/27/2023		N		303.92

Paid

GL NUMBER	DESCRIPTION	AMOUNT
101-301.000-755.000	COPY PAPER-PD	151.96
101-215.000-755.000	COPY PAPER-CH	25.33
101-253.000-755.000	COPY PAPER-CH	25.33
101-257.000-755.000	COPY PAPER-CH	25.33
101-257.000-755.000	COPY PAPER-CH	25.33
101-371.000-755.000	COPY PAPER-CH	25.33
592-543.000-755.000	COPY PAPER-CH	12.66
592-547.000-755.000	COPY PAPER-CH	12.65
		<u>303.92</u>

V024	FLAGSHIP-VISA	05/24/2023	STATEMENT	FTB	MARINA DNR GRANT SIGNAGE	
112583	3910 LAPEER RD	06/16/2023		N		219.50
06/02/2023	PORT HURON MI, 48060-2402	/ /	0.0000	N		0.00
		06/27/2023		N		219.50

Paid

GL NUMBER	DESCRIPTION	AMOUNT
101-756.000-974.000	CAPITAL OUTLAY-LAND IMPROVEMENTS	219.50

PAID
 DISBURSEMENTS - 06/16/23 TO 07/06/23

Vendor Code	Vendor name	Post Date	Invoice	Bank	Invoice Description	Gross Amount
Ref #	Address	CK Run Date	PO	Hold		Discount
Invoice Date	City/State/Zip	Disc. Date	Disc. %	Sep CK		Net Amount
Invoice Notes		Due Date		1099		

V024	FLAGSHIP-VISA	05/08/2023	STATEMENT	FTB	TONER CARTRIDGE/CM	
112545	3910 LAPEER RD	06/16/2023		N		90.96
06/02/2023	PORT HURON MI, 48060-2402	/ /	0.0000	N		0.00
		06/27/2023		N		90.96

Paid
 *AMAZON

GL NUMBER	DESCRIPTION	AMOUNT
101-172.000-755.000	TONERTONER CARTRIDGE/CM	90.96

V024	FLAGSHIP-VISA	06/01/2023	STATEMENT	FTB	WEED SPRAY/PARKS	
112546	3910 LAPEER RD	06/16/2023		N		190.79
06/01/2023	PORT HURON MI, 48060-2402	/ /	0.0000	N		0.00
		06/27/2023		N		190.79

Paid

GL NUMBER	DESCRIPTION	AMOUNT
101-756.000-934.000	WEED SPRAY/PARKS	190.79

V024	FLAGSHIP-VISA	05/01/2023	STATEMENT	FTB	FUEL-PD	
112547	3910 LAPEER RD	06/16/2023		N		55.00
06/02/2023	PORT HURON MI, 48060-2402	/ /	0.0000	N		0.00
		06/27/2023		N		55.00

Paid

GL NUMBER	DESCRIPTION	AMOUNT
101-301.000-759.000	FUEL-PD	55.00

VENDOR TOTAL: 1,380.80

B017	FOSTER BLUE WATER OIL LLC	06/14/2023	76557	FTB	KOST DEFENDAL HAND PUMP FUEL COST	
112679	PO BOX 550	07/06/2023		N		615.88
06/14/2023	RICHMOND MI, 48062-0550	/ /	0.0000	N		0.00
		07/14/2023		N		615.88

Paid

GL NUMBER	DESCRIPTION	AMOUNT
101-441.000-932.000	KOST DEFENDAL HAND PUMP FUEL COST	307.94
101-441.000-931.003	KOST DEFENDAL HAND PUMP FUEL COST	307.94

615.88

JOURNALIZED

PAID
 DISBURSEMENTS - 06/16/23 TO 07/06/23

Vendor Code	Vendor name	Post Date	Invoice	Bank	Invoice Description	Gross Amount
Ref #	Address	CK Run Date	PO	Hold		Discount
Invoice Date	City/State/Zip	Disc. Date	Disc. %	Sep CK		Net Amount
Invoice Notes		Due Date		1099		

B017	FOSTER BLUE WATER OIL LLC	06/14/2023	STATEMENT	FTB	DIESEL FUEL DPW	
112609	PO BOX 550	07/03/2023		N		2,184.71
06/15/2023	RICHMOND MI, 48062-0550	/ /	0.0000	N		0.00
		07/14/2023		N		2,184.71

Paid

GL NUMBER	DESCRIPTION	AMOUNT
101-441.000-758.000	DIESEL FUEL DPW	2,184.71

VENDOR TOTAL: 2,800.59

G004	GRAINGER	05/17/2023	9710570376	FTB	SELF PRIMING PUMP CAST IRON- WP	
112533	DEPT 803175678	06/16/2023		N		505.32
05/17/2023	PALATINE IL, 60038-0001	/ /	0.0000	N		0.00
		06/16/2023		N		505.32

Paid

GL NUMBER	DESCRIPTION	AMOUNT
592-549.000-931.003	SELF PRIMING PUMP CAST IRON- WP	505.32

VENDOR TOTAL: 505.32

H101	HAVILAND PRODUCTS COMPANY	06/22/2023	475081	FTB	WATER PLANT CHEMICALS	
112645	421 ANN STREET NW	07/03/2023		N		1,927.50
06/22/2023	GRAND RAPIDS MI, 49504-2075	/ /	0.0000	N		0.00
		07/22/2023		N		1,927.50

Paid

GL NUMBER	DESCRIPTION	AMOUNT
592-549.000-753.001	WATER PLANT CHEMICALS	1,927.50

VENDOR TOTAL: 1,927.50

H063	HI-TECH SYSTEM SERVICE	06/15/2023	75831	FTB	JULY BILLING	
112590	3070 PALMS ROAD	07/03/2023		N		1,570.00
06/15/2023	CASCO MI, 48064	/ /	0.0000	N		0.00
		07/15/2023		N		1,570.00

Paid

GL NUMBER	DESCRIPTION	AMOUNT
-----------	-------------	--------

JOURNALIZED

PAID

DISBURSEMENTS - 06/16/23 TO 07/06/23

Vendor Code	Vendor name	Post Date	Invoice	Bank	Invoice Description	Gross Amount
Ref #	Address	CK Run Date	PO	Hold		Discount
Invoice Date	City/State/Zip	Disc. Date	Disc. %	Sep CK		Net Amount
Invoice Notes		Due Date		1099		

101-265.000-948.000	JULY BILLING					1,570.00
VENDOR TOTAL:						1,570.00

0999	JEFF OLESKO	06/09/2023	STATEMENT	FTB	OVERTIME LUNCH MONIES WATERMAIN BREAK 6	
112605	156 CHARTIER ST APT 3	07/03/2023		N		10.00
06/15/2023	MARINE CITY MI, 48039	/ /	0.0000	N		0.00
		07/15/2023		N		10.00

Paid

GL NUMBER	DESCRIPTION	AMOUNT
101-441.000-722.001	OTLUNCH MONIES WATERMAIN BREAK 6/9/23	10.00
VENDOR TOTAL:		10.00

JS12	JEFF SCHMIDT	07/03/2023	STATEMENT	FTB	TECHNOLOGY STIPEND 2023/2024	
112639		07/03/2023		N		500.00
06/27/2023		/ /	0.0000	N		0.00
		07/01/2023		N		500.00

Paid

GL NUMBER	DESCRIPTION	AMOUNT
101-441.000-850.000	TECHNOLOGY STIPEND 2023/2024	500.00
VENDOR TOTAL:		500.00

J80	JOSHUA R DANNEELS	06/09/2023	STATEMENT	FTB	OVERTIME LUNCH MONIES WATERMAIN BREAK 6	
112602	1916 JACKSON ST.	07/03/2023		N		10.00
06/15/2023	SAINT CLAIR MI, 48079	/ /	0.0000	N		0.00
		07/15/2023		N		10.00

Paid

GL NUMBER	DESCRIPTION	AMOUNT
101-441.000-722.001	OT LUNCH MONIES WATERMAIN BREAK 6/9/23	10.00
VENDOR TOTAL:		10.00

KP01	KATY POSEY	07/03/2023	STATEMENT	FTB	POSEY TECHNOLOGY STIPEND 2023/2024	
112637	7188 MCKINLEY	07/03/2023		N		500.00
06/27/2023	COTTRELLVILLE TOWNSHIP MI, 48039	/ /	0.0000	N		0.00
		07/01/2023		N		500.00

PAID
 DISBURSEMENTS - 06/16/23 TO 07/06/23

Vendor Code	Vendor name	Post Date	Invoice	Bank	Invoice Description	Gross Amount
Ref #	Address	CK Run Date	PO	Hold		Discount
Invoice Date	City/State/Zip	Disc. Date	Disc. %	Sep CK		Net Amount
Invoice Notes		Due Date		1099		

Paid

GL NUMBER	DESCRIPTION	AMOUNT
101-253.000-850.000	POSEY TECHNOLOGY STIPEND 2023/2024	500.00
VENDOR TOTAL:		500.00

K125	KERR PUMP AND SUPPLY, INC.	06/19/2023	221940	FTB	TROUBLE SHOOT WATER TOWER	
112642	DRAWER 64185	07/03/2023		N		1,206.00
06/20/2023	DETROIT MI, 48264	/ /	0.0000	N		0.00
		07/20/2023		N		1,206.00

Paid

GL NUMBER	DESCRIPTION	AMOUNT
592-545.000-802.000	TROUBLE SHOOT WATER TOWER	1,206.00
VENDOR TOTAL:		1,206.00

M999	MARINE CITY AREA CHAMBER OFCOMMERCE	06/30/2023	1749	FTB	FOOD FOR TMOBILE GRANT RECEPTION	
112624	480 S WATER STREET	07/03/2023		N		225.14
03/16/2023	MARINE CITY MI, 48039	/ /	0.0000	N		0.00
		03/16/2023		N		225.14

Paid

GL NUMBER	DESCRIPTION	AMOUNT				
101-756.000-880.000-TL	REVITAL FOOD FOR TMOBILE GRANT RECEPTION	225.14				
M999	MARINE CITY AREA CHAMBER OFCOMMERCE	06/22/2023	1766	FTB	DISCOVER 48039 AD AND BROCHURES	
112626	480 S WATER STREET	07/03/2023		N		1,690.00
06/22/2023	MARINE CITY MI, 48039	/ /	0.0000	N		0.00
		06/22/2023		N		1,690.00

Paid

*CED APPROVED AT 5/24/23

GL NUMBER	DESCRIPTION	AMOUNT
101-701.000-752.002	CED EXPENSE	260.00
101-701.000-752.002	CED EXPENSE	1,430.00
VENDOR TOTAL:		1,690.00

VENDOR TOTAL: 1,915.14

JOURNALIZED

PAID

DISBURSEMENTS - 06/16/23 TO 07/06/23

Vendor Code	Vendor name	Post Date	Invoice	Bank	Invoice Description	Gross Amount
Ref #	Address	CK Run Date	PO	Hold		Discount
Invoice Date	City/State/Zip	Disc. Date	Disc. %	Sep CK		Net Amount
Invoice Notes		Due Date		1099		
M050	MARINE CITY NURSERY CO	05/25/2023	10564	FTB	HARDWOOD MULCH	
112515	PO BOX 189	06/16/2023		N		280.00
05/25/2023	MARINE CITY MI, 48039	/ /	0.0000	N		0.00
		06/24/2023		N		280.00

Paid

GL NUMBER	DESCRIPTION	AMOUNT
101-756.000-752.000	HARDWOOD MULCH	280.00

Vendor Code	Vendor name	Post Date	Invoice	Bank	Invoice Description	Gross Amount
Ref #	Address	CK Run Date	PO	Hold		Discount
Invoice Date	City/State/Zip	Disc. Date	Disc. %	Sep CK		Net Amount
Invoice Notes		Due Date		1099		
M050	MARINE CITY NURSERY CO	05/26/2023	10582	FTB	HARDWOOD MULCH	
112516	PO BOX 189	06/16/2023		N		140.00
05/26/2023	MARINE CITY MI, 48039	/ /	0.0000	N		0.00
		06/25/2023		N		140.00

Paid

GL NUMBER	DESCRIPTION	AMOUNT
101-756.000-752.000	HARDWOOD MULCH	140.00

Vendor Code	Vendor name	Post Date	Invoice	Bank	Invoice Description	Gross Amount
Ref #	Address	CK Run Date	PO	Hold		Discount
Invoice Date	City/State/Zip	Disc. Date	Disc. %	Sep CK		Net Amount
Invoice Notes		Due Date		1099		
M050	MARINE CITY NURSERY CO	05/26/2023	10585	FTB	HARDWOOD MULCH	
112517	PO BOX 189	06/16/2023		N		140.00
05/26/2023	MARINE CITY MI, 48039	/ /	0.0000	N		0.00
		06/25/2023		N		140.00

Paid

GL NUMBER	DESCRIPTION	AMOUNT
101-756.000-752.000	HARDWOOD MULCH	140.00

Vendor Code	Vendor name	Post Date	Invoice	Bank	Invoice Description	Gross Amount
Ref #	Address	CK Run Date	PO	Hold		Discount
Invoice Date	City/State/Zip	Disc. Date	Disc. %	Sep CK		Net Amount
Invoice Notes		Due Date		1099		
M050	MARINE CITY NURSERY CO	06/01/2023	10701	FTB	BLACK MULCH CITY OFFICES	
112518	PO BOX 189	06/16/2023		N		152.00
06/01/2023	MARINE CITY MI, 48039	/ /	0.0000	N		0.00
		07/01/2023		N		152.00

Paid

GL NUMBER	DESCRIPTION	AMOUNT
101-265.000-752.000	BLACK MULCH CITY OFFICES	152.00

Vendor Code	Vendor name	Post Date	Invoice	Bank	Invoice Description	Gross Amount
Ref #	Address	CK Run Date	PO	Hold		Discount
Invoice Date	City/State/Zip	Disc. Date	Disc. %	Sep CK		Net Amount
Invoice Notes		Due Date		1099		
M050	MARINE CITY NURSERY CO	06/01/2023	10709	FTB	BLACK MULCH LIBRARY	
112519	PO BOX 189	06/16/2023		N		152.00
06/01/2023	MARINE CITY MI, 48039	/ /	0.0000	N		0.00
		06/29/2023		N		152.00

Paid

JOURNALIZED

PAID

DISBURSEMENTS - 06/16/23 TO 07/06/23

Vendor Code	Vendor name	Post Date	Invoice	Bank	Invoice Description	Gross Amount
Ref #	Address	CK Run Date	PO	Hold		Discount
Invoice Date	City/State/Zip	Disc. Date	Disc. %	Sep CK		Net Amount
Invoice Notes		Due Date		1099		

GL NUMBER	DESCRIPTION	AMOUNT
101-790.000-752.000	BLACK MULCH LIBRARY	152.00
VENDOR TOTAL:		864.00

MC01	MCKENNA	05/31/2023	23-026-1	FTB	PROJECT 23-026 PROFESSIONAL SERVICES MA	
112591	235 EAST MAIN ST	07/03/2023		N		1,900.00
	SUITE 105					
06/08/2023	NORTHVILLE MI, 48167	/ /	0.0000	N		0.00
		07/08/2023		N		1,900.00

Paid
*MASTER PLAN AND PARKS AND RECREATION PLAN

GL NUMBER	DESCRIPTION	AMOUNT
101-701.000-801.000	PROJECT 23-026 PROFESSIONAL SERVICES MAY	1,900.00
VENDOR TOTAL:		1,900.00

M010	MECHANICAL FABRICATORS INC	05/22/2023	44954	FTB	WWTP GRATES	
112525	770 DEGURSE	06/16/2023		N		1,342.00
05/22/2023	MARINE CITY MI, 48039	/ /	0.0000	N		0.00
		06/21/2023		N		1,342.00

Paid

GL NUMBER	DESCRIPTION	AMOUNT
592-545.000-934.000	WWTP GRATES	1,342.00
VENDOR TOTAL:		1,342.00

M0236	MERSINO DEWATERING LLC	06/22/2023	105442	FTB	BYPASS RENTAL 5/25-6/22/23	
112644	900 N SQUIRREL RD STE 210	07/03/2023		N		11,031.62
06/13/2023	AUBURN HILLS MI, 48326	/ /	0.0000	N		0.00
		07/13/2023		N		11,031.62

Paid

GL NUMBER	DESCRIPTION	AMOUNT
592-545.000-940.000	BYPASS RENTAL 5/25-6/22/23	11,031.62
VENDOR TOTAL:		11,031.62

MIT01	MI DEPARTMENT OF TREASURY	06/27/2023	STATEMENT	FTB	PENALTY AND INTEREST PAYROLL WITHHOLDIN	
-------	---------------------------	------------	-----------	-----	---	--

JOURNALIZED

PAID

DISBURSEMENTS - 06/16/23 TO 07/06/23

Vendor Code	Vendor name	Post Date	Invoice	Bank	Invoice Description	Gross Amount
Ref #	Address	CK Run Date	PO	Hold		Discount
Invoice Date	City/State/Zip	Disc. Date	Disc. %	Sep CK		Net Amount
Invoice Notes		Due Date		1099		
112651	430 W ALLEGAN ST	07/03/2023		N		322.39
06/27/2023	LANSING MI, 48933	/ /	0.0000	N		0.00
		07/27/2023		N		322.39

Paid

GL NUMBER	DESCRIPTION	AMOUNT
101-253.000-805.000	PENALTY	315.55
101-253.000-805.000	INTEREST	6.84
		<u>322.39</u>

VENDOR TOTAL: 322.39

I007	MICHAEL P ITRICH	06/30/2023	STATEMENT	FTB	MONTHLY FLAT RATE WATER SYSTEM REPORTS	
112691	349 NORTH AVENUE	07/06/2023		N		400.00
07/06/2023	ALGONAC MI, 48001	/ /	0.0000	N		0.00
		07/28/2023		N		400.00

Paid

GL NUMBER	DESCRIPTION	AMOUNT
101-441.000-802.000	MTHLY FLAT RATE WATER SYSTEM REPORT JUNE	200.00
592-545.000-802.000	MTHLY FLAT RATE WATER SYSTEM REPORT JUNE	200.00
		<u>400.00</u>

I007	MICHAEL P ITRICH	05/31/2023	STATEMENT	FTB	MONTHLY FLAT RATE WATER SYSTEM REPORTS	
112692	349 NORTH AVENUE	07/06/2023		N		400.00
07/06/2023	ALGONAC MI, 48001	/ /	0.0000	N		0.00
		07/28/2023		N		400.00

Paid

GL NUMBER	DESCRIPTION	AMOUNT
101-441.000-802.000	MONTHLY FLAT RATE WATER SYSTEM REPORTS M	200.00
592-545.000-802.000	MONTHLY FLAT RATE WATER SYSTEM REPORTS M	200.00
		<u>400.00</u>

VENDOR TOTAL: 800.00

M333	MICHIGAN AGRIBUSINESS SOLUTIONS	06/12/2023	2408	FTB	BIOSOLID REMOVAL	
112610	3050 FREEWAY LANE	07/03/2023		N		38,431.25
06/12/2023	SAGINAW MI, 48601	/ /	0.0000	N		0.00
		07/12/2023		N		38,431.25

JOURNALIZED

PAID

DISBURSEMENTS - 06/16/23 TO 07/06/23

Vendor Code	Vendor name	Post Date	Invoice	Bank	Invoice Description	Gross Amount
Ref #	Address	CK Run Date	PO	Hold		Discount
Invoice Date	City/State/Zip	Disc. Date	Disc. %	Sep CK		Net Amount
Invoice Notes		Due Date		1099		

Paid

GL NUMBER	DESCRIPTION	AMOUNT
592-545.000-802.100	BIOSOLIDS REMOVAL	38,431.25
VENDOR TOTAL:		38,431.25

MR123	MIKAYLA ROY	05/17/2023	STATEMENT	FTB	MILEAGE REIMBURSEMENT	
112592	6659 SHEA ROAD	07/03/2023		N		19.65
06/01/2023	COTTRELLVILLE TOWNSHIP MI, 48039	/ /	0.0000	N		0.00
		06/30/2023		N		19.65

Paid

*5/17/23 MARYSVILLE WATERSHED MEETING 30 MILES 65.5 CENTS

GL NUMBER	DESCRIPTION	AMOUNT
101-441.000-861.000	TRANSPORTATION-MILEAGE REIMBURSEMENT	19.65
VENDOR TOTAL:		19.65

N044	NCL OF WISCONSIN	05/16/2023	487366	FTB	WWTP SUPPLIES	
112520	PO BOX 8	06/16/2023		N		207.69
05/16/2023	BIRNAMWOOD WI, 54414	/ /	0.0000	N		0.00
		06/15/2023		N		207.69

Paid

GL NUMBER	DESCRIPTION	AMOUNT
592-545.000-752.000	WWTP SUPPLIES	207.69
VENDOR TOTAL:		207.69

P019	PRIOR PLUMBING & HEATING INC	05/25/2023	070324	FTB	FAUCET/VALVE - PARKS	
112512	3478 PTE TREMBLE RD	06/16/2023		N		502.02
05/25/2023	ALGONAC MI, 48001	/ /	0.0000	N		0.00
		06/30/2023		N		502.02

Paid

GL NUMBER	DESCRIPTION	AMOUNT				
101-756.000-934.000	FAUCET/VALVE - PARKS	502.02				
P019	PRIOR PLUMBING & HEATING INC	05/30/2023	070346	FTB	FAUCET-PARKS	
112511	3478 PTE TREMBLE RD	06/16/2023		N		306.26

JOURNALIZED

PAID

DISBURSEMENTS - 06/16/23 TO 07/06/23

Vendor Code	Vendor name	Post Date	Invoice	Bank	Invoice Description	Gross Amount
Ref #	Address	CK Run Date	PO	Hold		Discount
Invoice Date	City/State/Zip	Disc. Date	Disc. %	Sep CK		Net Amount
Invoice Notes		Due Date		1099		
05/30/2023	ALGONAC MI, 48001	/ /	0.0000	N		0.00
		06/30/2023		N		306.26

Paid

GL NUMBER	DESCRIPTION	AMOUNT
101-756.000-934.000	FAUCET-PARKS	306.26
VENDOR TOTAL:		808.28

S201	SANTANDER BANK, N.A.	07/01/2023	5683554	FTB	VACUUM TRUCK LEASE	
112527	P.O. BOX 847386	07/03/2023		N		67,023.48
05/31/2023	BOSTON MA, 02284-7387	/ /	0.0000	N		0.00
		07/15/2023		N		67,023.48

Paid

GL NUMBER	DESCRIPTION	AMOUNT
592-548.000-992.000	VACUUM TRUCK LEASE	1,241.74
592-000.000-304.000	VACUUM TRUCK LEASE	32,270.00
592-000.000-304.000	VACUUM TRUCK LEASE	32,270.00
592-544.000-992.000	VACUUM TRUCK LEASE	1,241.74
VENDOR TOTAL:		67,023.48

S122	SCOTT ADKINS	07/03/2023	STATEMENT	FTB	TECHNOLOGY STIPEND 2023/2024	
112638	717 WITHERELL ST	07/03/2023		N		500.00
06/27/2023	SAINT CLAIR MI, 48079	/ /	0.0000	N		0.00
		07/01/2023		N		500.00

Paid

GL NUMBER	DESCRIPTION	AMOUNT
101-172.000-850.000	TECHNOLOGY STIPEND 2023/2024	500.00
VENDOR TOTAL:		500.00

S012	SEMCO ENERGY GAS CO	05/17/2023	STATEMENT	FTB	260 S PARKER-CH	
112558	PO BOX 740812	06/16/2023		N		53.67
06/14/2023	CINCINNATI OH, 45274-0812	/ /	0.0000	N		0.00
		06/27/2023		N		53.67

Paid

*4/26-5/17/23

07/12/2023 03:38 PM
 User: POSEY
 DB: Marine City

INVOICE APPROVAL BY INVOICE REPORT FOR CITY OF MARINE CITY
 EXP CHECK RUN DATES 06/16/2023 - 07/06/2023
 JOURNALIZED

PAID
 DISBURSEMENTS - 06/16/23 TO 07/06/23

Vendor Code	Vendor name	Post Date	Invoice	Bank	Invoice Description	Gross Amount
Ref #	Address	CK Run Date	PO	Hold		Discount
Invoice Date	City/State/Zip	Disc. Date	Disc. %	Sep CK		Net Amount
Invoice Notes		Due Date		1099		

GL NUMBER	DESCRIPTION	AMOUNT
101-265.000-921.002	260 S PARKER-CH	53.67
S012	SEMCO ENERGY GAS CO	05/24/2023
112559	PO BOX 740812	06/16/2023
06/14/2023	CINCINNATI OH, 45274-0812	/ / 0.0000
		06/26/2023
		FTB 300 BROADWAY
		N 74.06
		N 0.00
		N 74.06

Paid
 *4/25-5/24/23

GL NUMBER	DESCRIPTION	AMOUNT
101-265.000-921.002	300 BROADWAY	74.06
S012	SEMCO ENERGY GAS CO	05/25/2023
112560	PO BOX 740812	06/16/2023
06/14/2023	CINCINNATI OH, 45274-0812	/ / 0.0000
		06/27/2023
		FTB 304 S BELLE RIVER AVE
		N 35.62
		N 0.00
		N 35.62

Paid
 *4/26-5/25/23

GL NUMBER	DESCRIPTION	AMOUNT
592-546.000-921.002	304 S BELLE RIVER AVE	35.62
S012	SEMCO ENERGY GAS CO	05/25/2023
112561	PO BOX 740812	06/16/2023
06/14/2023	CINCINNATI OH, 45274-0812	/ / 0.0000
		06/27/2023
		FTB 260 S PARKER-CH
		N 107.00
		N 0.00
		N 107.00

Paid
 *4/26-5/19/23 535659
 5/19-5/25/23 614329

GL NUMBER	DESCRIPTION	AMOUNT
101-265.000-921.002	260 S PARKER-CH	107.00
S012	SEMCO ENERGY GAS CO	05/25/2023
112562	PO BOX 740812	06/16/2023
06/14/2023	CINCINNATI OH, 45274-0812	/ / 0.0000
		06/27/2023
		FTB 300 S PARKER ST LIBRARY
		N 48.95
		N 0.00
		N 48.95

Paid
 *4/26-5/25/23

User: POSEY

EXP CHECK RUN DATES 06/16/2023 - 07/06/2023

DB: Marine City

JOURNALIZED

PAID

DISBURSEMENTS - 06/16/23 TO 07/06/23

Vendor Code	Vendor name	Post Date	Invoice	Bank	Invoice Description	Gross Amount
Ref #	Address	CK Run Date	PO	Hold		Discount
Invoice Date	City/State/Zip	Disc. Date	Disc. %	Sep CK		Net Amount
Invoice Notes		Due Date		1099		

GL NUMBER	DESCRIPTION	AMOUNT
101-790.000-921.002	300 S PARKER ST LIBRARY	48.95
S012	SEMCO ENERGY GAS CO	05/25/2023
112563	PO BOX 740812	06/16/2023
06/14/2023	CINCINNATI OH, 45274-0812	/ / 0.0000
		06/27/2023
		FTB 375 S PARKER ST
		N 45.14
		N 0.00
		N 45.14

Paid
*4/26-5/25/23

GL NUMBER	DESCRIPTION	AMOUNT
101-301.000-921.002	375 S PARKER ST	45.14
S012	SEMCO ENERGY GAS CO	05/25/2023
112564	PO BOX 740812	06/16/2023
06/14/2023	CINCINNATI OH, 45274-0812	/ / 0.0000
		06/27/2023
		FTB 514 S PARKER ST
		N 175.44
		N 0.00
		N 175.44

Paid
*4-26/5-25-23

GL NUMBER	DESCRIPTION	AMOUNT
101-441.000-921.002	514 S PARKER ST	175.44
S012	SEMCO ENERGY GAS CO	05/25/2023
112565	PO BOX 740812	06/16/2023
06/14/2023	CINCINNATI OH, 45274-0812	/ / 0.0000
		06/27/2023
		FTB 1696 S PARKER ST
		N 255.06
		N 0.00
		N 255.06

Paid
*4-26/5-25-23

GL NUMBER	DESCRIPTION	AMOUNT
592-545.000-921.002	1696 S PARKER ST	255.06
S012	SEMCO ENERGY GAS CO	05/24/2023
112566	PO BOX 740812	06/16/2023
06/14/2023	CINCINNATI OH, 45274-0812	/ / 0.0000
		06/26/2023
		FTB 405 S MAIN ST
		N 75.58
		N 0.00
		N 75.58

Paid
*4-25/5-24-23

GL NUMBER	DESCRIPTION	AMOUNT
101-804.000-921.002	405 S MAIN ST	75.58

User: POSEY

EXP CHECK RUN DATES 06/16/2023 - 07/06/2023

DB: Marine City

JOURNALIZED

PAID

DISBURSEMENTS - 06/16/23 TO 07/06/23

Vendor Code	Vendor name	Post Date	Invoice	Bank	Invoice Description	Gross Amount
Ref #	Address	CK Run Date	PO	Hold		Discount
Invoice Date	City/State/Zip	Disc. Date	Disc. %	Sep CK		Net Amount
Invoice Notes		Due Date		1099		

S012	SEMCO ENERGY GAS CO	05/24/2023	STATEMENT	FTB	229 S WATER ST	
112567	PO BOX 740812	06/16/2023		N		119.46
06/14/2023	CINCINNATI OH, 45274-0812	/ /	0.0000	N		0.00
		06/26/2023		N		119.46

Paid
*4-25/5-24-23
GENERATOR

GL NUMBER	DESCRIPTION	AMOUNT
592-549.000-921.002	229 S WATER ST	119.46

S012	SEMCO ENERGY GAS CO	05/24/2023	STATEMENT	FTB	231 S WATER ST	
112568	PO BOX 740812	06/16/2023		N		331.83
06/14/2023	CINCINNATI OH, 45274-0812	/ /	0.0000	N		0.00
		06/26/2023		N		331.83

Paid
*04/25-05/24/2023

GL NUMBER	DESCRIPTION	AMOUNT
592-549.000-921.002	231 S WATER ST	331.83

VENDOR TOTAL: 1,321.81

S157	SIDELINE ELECTRIC	05/23/2023	1996	FTB	LIBRARY SERVICE LIGHT SWITCH	
112650	7838 MARSH RD	07/03/2023		N		115.00
06/14/2023	COTTRELLVILLE TWP MI, 48039	/ /	0.0000	N		0.00
		07/14/2023		Y		115.00

Paid

GL NUMBER	DESCRIPTION	AMOUNT
101-265.000-930.000	LIBRARY SERVICE LIGHT SWITCH	115.00

S157	SIDELINE ELECTRIC	05/26/2023	1997	FTB	DPW COMPRESSOR CALL	
112648	7838 MARSH RD	07/03/2023		N		248.25
06/14/2023	COTTRELLVILLE TWP MI, 48039	/ /	0.0000	N		0.00
		07/14/2023		Y		248.25

Paid

GL NUMBER	DESCRIPTION	AMOUNT
101-265.000-930.000	DPW COMPRESSOR CALL	248.25

User: POSEY
DB: Marine City

EXP CHECK RUN DATES 06/16/2023 - 07/06/2023

JOURNALIZED

PAID

DISBURSEMENTS - 06/16/23 TO 07/06/23

Vendor Code	Vendor name	Post Date	Invoice	Bank	Invoice Description	Gross Amount
Ref #	Address	CK Run Date	PO	Hold		Discount
Invoice Date	City/State/Zip	Disc. Date	Disc. %	Sep CK		Net Amount
Invoice Notes		Due Date		1099		
S157	SIDELINE ELECTRIC	05/31/2023	1998	FTB	WWP SERVICE CLARIFIER	
112649	7838 MARSH RD	07/03/2023		N		280.00
05/14/2023	COTTRELLVILLE TWP MI, 48039	/ /	0.0000	N		0.00
		07/14/2023		Y		280.00

Paid

GL NUMBER	DESCRIPTION	AMOUNT
592-546.000-931.003	WWP SERVICE CLARIFIER	280.00

VENDOR TOTAL: 643.25

Vendor Code	Vendor name	Post Date	Invoice	Bank	Invoice Description	Gross Amount
Ref #	Address	CK Run Date	PO	Hold		Discount
Invoice Date	City/State/Zip	Disc. Date	Disc. %	Sep CK		Net Amount
Invoice Notes		Due Date		1099		
SKI999	SKIP PRINTING	06/05/2023	84621	FTB	TAX WHITE ENVELOPES AND WHITE PAPER	
112585	28032 GROESBECK	07/03/2023		N		575.00
06/05/2023	ROSEVILLE MI, 48066	/ /	0.0000	N		0.00
		07/05/2023		N		575.00

Paid

GL NUMBER	DESCRIPTION	AMOUNT
101-253.000-900.000	TAX WHITE ENVELOPES AND WHITE PAPER	575.00

VENDOR TOTAL: 575.00

Vendor Code	Vendor name	Post Date	Invoice	Bank	Invoice Description	Gross Amount
Ref #	Address	CK Run Date	PO	Hold		Discount
Invoice Date	City/State/Zip	Disc. Date	Disc. %	Sep CK		Net Amount
Invoice Notes		Due Date		1099		
S021	ST CLAIR CO ROAD COMMISSION	05/31/2023	513761	FTB	TRAFFIC FLASHER KING MAIN	
112613	21 AIRPORT ROAD	07/03/2023		N		4.27
06/07/2023	ST CLAIR MI, 48079-1404	/ /	0.0000	N		0.00
		07/07/2023		N		4.27

Paid

GL NUMBER	DESCRIPTION	AMOUNT
202-456.000-802.000	TRAFFIC FLASHER KING MAIN	4.27

VENDOR TOTAL: 4.27

Vendor Code	Vendor name	Post Date	Invoice	Bank	Invoice Description	Gross Amount
Ref #	Address	CK Run Date	PO	Hold		Discount
Invoice Date	City/State/Zip	Disc. Date	Disc. %	Sep CK		Net Amount
Invoice Notes		Due Date		1099		
S038	STATE OF MICHIGAN	03/28/2023	551-614198	FTB	FINGERPRINTING	
112539	MI STATE POLICE-CASHIERS OFFICE	06/16/2023		N		43.25
04/06/2023	PO BOX 30266	/ /	0.0000	N		0.00
	LANSING MI, 48909	06/16/2023		N		43.25

Paid

*OLIVIA GILLESPIE 3/28/23

GL NUMBER	DESCRIPTION	AMOUNT
-----------	-------------	--------

JOURNALIZED
 PAID
 DISBURSEMENTS - 06/16/23 TO 07/06/23

Vendor Code	Vendor name	Post Date	Invoice	Bank	Invoice Description	Gross Amount
Ref #	Address	CK Run Date	PO	Hold		Discount
Invoice Date	City/State/Zip	Disc. Date	Disc. %	Sep CK		Net Amount
Invoice Notes		Due Date		1099		
101-301.000-802.000	FINGERPRINTING					43.25
S038	STATE OF MICHIGAN	05/31/2023	551-618795	FTB	SEX OFFENDER REG	
112540	MI STATE POLICE-CASHIERS OFFICE	06/16/2023		N		30.00
	PO BOX 30266	/ /	0.0000	N		0.00
06/08/2023	LANSING MI, 48909	06/16/2023		N		30.00
Paid						
*AMANDA KLEMM KAY 5/31/23						
GL NUMBER	DESCRIPTION				AMOUNT	
101-000.000-228.630	SEX OFFENDER REG				30.00	

VENDOR TOTAL: 73.25

T996	THE STANDARD - DENTAL INSURANCE	06/01/2023	STATEMENT	FTB	MONTHLY DENTAL ACTIVE 06/23	
112549	PO BOX 650804	06/16/2023		N		683.51
06/01/2023	DALLAS TX, 75265-0804	/ /	0.0000	N		0.00
		06/16/2023		N		683.51

Paid
 *06/01/23 - 06/30/23

GL NUMBER	DESCRIPTION	AMOUNT
101-215.000-718.001	MONTHLY DENTAL ACTIVE 06/23	12.79
101-253.000-718.001	MONTHLY DENTAL ACTIVE 06/23	130.37
101-301.000-718.001	MONTHLY DENTAL ACTIVE 06/23	242.05
101-441.000-718.001	MONTHLY DENTAL ACTIVE 06/23	8.53
202-450.000-718.001	MONTHLY DENTAL ACTIVE 06/23	119.65
203-450.000-718.001	MONTHLY DENTAL ACTIVE 06/23	19.94
592-543.000-718.001	MONTHLY DENTAL ACTIVE 06/23	29.91
592-547.000-718.001	MONTHLY DENTAL ACTIVE 06/23	51.16
101-371.000-718.001	MONTHLY DENTAL ACTIVE 06/23	69.11
		683.51

T996	THE STANDARD - DENTAL INSURANCE	06/01/2023	STATEMENT	FTB	MONTHLY DENTAL RETIREE 06/23	
112550	PO BOX 650804	06/16/2023		N		1,491.93
06/01/2023	DALLAS TX, 75265-0804	/ /	0.0000	N		0.00
		06/16/2023		N		1,491.93

Paid
 *06/01/23 - 06/30/23

GL NUMBER	DESCRIPTION	AMOUNT
-----------	-------------	--------

JOURNALIZED
 PAID

DISBURSEMENTS - 06/16/23 TO 07/06/23

Vendor Code	Vendor name	Post Date	Invoice	Bank	Invoice Description	Gross Amount
Ref #	Address	CK Run Date	PO	Hold		Discount
Invoice Date	City/State/Zip	Disc. Date	Disc. %	Sep CK		Net Amount
Invoice Notes		Due Date		1099		

736-000.000-723.000	MONTHLY DENTAL RETIREE 06/23				1,491.93	
VENDOR TOTAL:						2,175.44

T997	THE STANDARD - LIFE INSURANCE	07/01/2023	STATEMENT	FTB	MONTHLY LIFE INSURANCE JULY 2023	
112596	PO BOX 5676	07/03/2023		N		177.30
06/14/2023	PORTLAND OR, 97228-5676	/ /	0.0000	N		0.00
		07/01/2023		N		177.30

Paid

GL NUMBER	DESCRIPTION	AMOUNT
101-215.000-726.000	MONTHLY LIFE INSURANCE JULY 2023	3.96
101-301.000-726.000	MONTHLY LIFE INSURANCE JULY 2023	79.20
101-441.000-726.000	MONTHLY LIFE INSURANCE JULY 2023	34.20
101-253.000-726.000	MONTHLY LIFE INSURANCE JULY 2023	20.93
202-450.000-726.000	MONTHLY LIFE INSURANCE JULY 2023	5.70
203-450.000-726.000	MONTHLY LIFE INSURANCE JULY 2023	8.55
592-543.000-726.000	MONTHLY LIFE INSURANCE JULY 2023	9.82
592-547.000-726.000	MONTHLY LIFE INSURANCE JULY 2023	14.94
		177.30

VENDOR TOTAL: 177.30

T125	TK & ASSOCIATES LLC	06/07/2023	8471	FTB	2 SEMI LOAD SAND DPW YARD	
112647	7485 SHEA ROAD	07/03/2023		N		720.00
06/12/2023	COTTRELLVILLE TOWNSHIP MI, 48039	/ /	0.0000	N		0.00
		07/12/2023		N		720.00

Paid

GL NUMBER	DESCRIPTION	AMOUNT
592-545.000-930.000	2 SEMI LOAD SAND DPW YARD	720.00

T125	TK & ASSOCIATES LLC	06/08/2023	8472	FTB	SEMI LOAD TOP SOIL CEMETERY	
112646	7485 SHEA ROAD	07/03/2023		N		525.00
06/12/2023	COTTRELLVILLE TOWNSHIP MI, 48039	/ /	0.0000	N		0.00
		07/12/2023		N		525.00

Paid

GL NUMBER	DESCRIPTION	AMOUNT
592-545.000-930.000	SEMI LOAD TOP SOIL	262.50
101-756.000-930.000	LAND & BUILDING REPAIRS	262.50

07/12/2023 03:38 PM
 User: POSEY
 DB: Marine City

INVOICE APPROVAL BY INVOICE REPORT FOR CITY OF MARINE CITY
 EXP CHECK RUN DATES 06/16/2023 - 07/06/2023
 JOURNALIZED

PAID
 DISBURSEMENTS - 06/16/23 TO 07/06/23

Vendor Code	Vendor name	Post Date	Invoice	Bank	Invoice Description	Gross Amount
Ref #	Address	CK Run Date	PO	Hold		Discount
Invoice Date	City/State/Zip	Disc. Date	Disc. %	Sep CK		Net Amount
Invoice Notes		Due Date		1099		

525.00

VENDOR TOTAL: 1,245.00

TK16	T-K INSPECTIONS LLC	05/31/2023	165	FTB	BUILDING MAY 2023	
112595	3210 CHURCH RD	07/03/2023		N		4,643.75
06/20/2023	CASCO MI, 48064	/ /	0.0000	N		0.00
		07/20/2023		N		4,643.75

Paid

GL NUMBER	DESCRIPTION	AMOUNT
101-371.000-802.000	BUILDING MAY 2023	4,643.75

VENDOR TOTAL: 4,643.75

TOS999	TOSHIBA FINANCIAL SERVICES	06/01/2023	503503997	FTB	MONTHLY COPIER LEASE-CH	
112573	PO BOX 790448	06/16/2023		N		290.00
06/07/2023	SAINT LOUIS MO, 63179-0448	/ /	0.0000	N		0.00
		07/01/2023		N		290.00

Paid

*06/01/2023 -07/01/2023

GL NUMBER	DESCRIPTION	AMOUNT
101-265.000-884.000	MONTHLY COPIER LEASE-CH	290.00

TOS999	TOSHIBA FINANCIAL SERVICES	06/01/2023	503504144	FTB	MONTHLY COPIER LEASE-PD	
112542	PO BOX 790448	06/16/2023		N		60.00
06/07/2023	SAINT LOUIS MO, 63179-0448	/ /	0.0000	N		0.00
		07/01/2023		N		60.00

Paid

*06/01/2023 - 07/01/2023

GL NUMBER	DESCRIPTION	AMOUNT
101-301.000-884.000	MONTHLY COPIER LEASE-PD	60.00

TOS999	TOSHIBA FINANCIAL SERVICES	05/01/2023	503504144A	FTB	COLORED COPIES/OVERAGE-PD	
112584	PO BOX 790448	06/16/2023		N		13.14
06/07/2023	SAINT LOUIS MO, 63179-0448	/ /	0.0000	N		0.00
		07/01/2023		N		13.14

Paid

*05/01/23 - 06/01/23

07/12/2023 03:38 PM
 User: POSEY
 DB: Marine City

INVOICE APPROVAL BY INVOICE REPORT FOR CITY OF MARINE CITY
 EXP CHECK RUN DATES 06/16/2023 - 07/06/2023

JOURNALIZED

PAID

DISBURSEMENTS - 06/16/23 TO 07/06/23

Vendor Code	Vendor name	Post Date	Invoice	Bank	Invoice Description	Gross Amount
Ref #	Address	CK Run Date	PO	Hold		Discount
Invoice Date	City/State/Zip	Disc. Date	Disc. %	Sep CK		Net Amount
Invoice Notes		Due Date		1099		

GL NUMBER	DESCRIPTION	AMOUNT
101-301.000-884.000	COLORED COPIES/OVERAGE-PD	13.14
VENDOR TOTAL:		363.14

U029	USA BLUEBOOK	05/18/2023	15979	FTB	WP LAB SUPPLY	
112513	PO BOX 9004	06/16/2023		N		251.74
05/18/2023	GURNEE IL, 60031-9004	/ /	0.0000	N		0.00
		06/17/2023		N		251.74
Paid						

GL NUMBER	DESCRIPTION	AMOUNT				
592-549.000-762.000	WWP LAB SUPPLY	251.74				
U029	USA BLUEBOOK	05/19/2023	17191	FTB	WP LAB SUPPLY	
112514	PO BOX 9004	06/16/2023		N		141.31
05/19/2023	GURNEE IL, 60031-9004	/ /	0.0000	N		0.00
		06/18/2023		N		141.31
Paid						

GL NUMBER	DESCRIPTION	AMOUNT				
592-549.000-762.000	WWP LAB SUPPLY	141.31				
U029	USA BLUEBOOK	06/28/2023	32510	FTB	WWTP MESH BAG	
112654	PO BOX 9004	07/03/2023		N		49.95
06/06/2023	GURNEE IL, 60031-9004	/ /	0.0000	N		0.00
		06/06/2023		N		49.95
Paid						

GL NUMBER	DESCRIPTION	AMOUNT				
592-545.000-762.000	WWTP MESH BAG	49.95				
U029	USA BLUEBOOK	06/08/2023	35780	FTB	WWTP CHEMICAL	
112653	PO BOX 9004	07/03/2023		N		135.54
06/08/2023	GURNEE IL, 60031-9004	/ /	0.0000	N		0.00
		07/08/2023		N		135.54
Paid						

GL NUMBER	DESCRIPTION	AMOUNT
592-545.000-762.000	WWTP CHEMICAL	135.54

07/12/2023 03:38 PM
 User: POSEY
 DB: Marine City

INVOICE APPROVAL BY INVOICE REPORT FOR CITY OF MARINE CITY
 EXP CHECK RUN DATES 06/16/2023 - 07/06/2023

JOURNALIZED

PAID

DISBURSEMENTS - 06/16/23 TO 07/06/23

Vendor Code	Vendor name	Post Date	Invoice	Bank	Invoice Description	Gross Amount
Ref #	Address	CK Run Date	PO	Hold		Discount
Invoice Date	City/State/Zip	Disc. Date	Disc. %	Sep CK		Net Amount
Invoice Notes		Due Date		1099		

U029	USA BLUEBOOK	06/13/2023	42375	FTB	WWTP ELECTRODE	
112652	PO BOX 9004	07/03/2023		N		713.06
06/13/2023	GURNEE IL, 60031-9004	/ /	0.0000	N		0.00
		07/13/2023		N		713.06

Paid

GL NUMBER	DESCRIPTION	AMOUNT
592-545.000-762.000	WWTP ELECTRODE	713.06

VENDOR TOTAL: 1,291.60

U101	USA TODAY NETWORK	05/14/2023	STATEMENT	FTB	23/24 BUDGET PUBLIC HEARING NOTICE	
112574		06/16/2023		N		95.95
05/14/2023	P.O. BOX 677313	/ /	0.0000	N		0.00
	DALLAS TX, 75267-7313	06/20/2023		N		95.95

Paid

GL NUMBER	DESCRIPTION	AMOUNT
101-215.000-902.000	23/24 BUDGET PUBLIC HEARING NOTICE	95.95

VENDOR TOTAL: 95.95

V006	VERIZON WIRELESS	06/23/2023	9938044522	FTB	(4) IN CAR MODEMS PD	
112690	PO BOX 15062	07/06/2023		N		190.35
06/23/2023	ALBANY NY, 12212-5062	/ /	0.0000	N		0.00
		07/15/2023		N		190.35

Paid

GL NUMBER	DESCRIPTION	AMOUNT
592-549.000-802.000	(4) IN CAR MODEMS PD	114.33
101-301.000-850.000	(4) IN CAR MODEMS PD	76.02

190.35

VENDOR TOTAL: 190.35

V022	VESCO OIL CORP	05/19/2023	5374129-00	FTB	WASTE PICKUP FEES	
112528	PO BOX 675371	06/16/2023		N		78.25
05/19/2023	DETROIT MI, 48267-5371	/ /	0.0000	N		0.00
		06/18/2023		N		78.25

07/12/2023 03:38 PM
 User: POSEY
 DB: Marine City

INVOICE APPROVAL BY INVOICE REPORT FOR CITY OF MARINE CITY
 EXP CHECK RUN DATES 06/16/2023 - 07/06/2023

JOURNALIZED

PAID

DISBURSEMENTS - 06/16/23 TO 07/06/23

Vendor Code	Vendor name	Post Date	Invoice	Bank	Invoice Description	Gross Amount
Ref #	Address	CK Run Date	PO	Hold		Discount
Invoice Date	City/State/Zip	Disc. Date	Disc. %	Sep CK		Net Amount
Invoice Notes		Due Date		1099		

Paid

GL NUMBER	DESCRIPTION	AMOUNT
101-441.000-932.000	WASTE PICKUP FEES	78.25
VENDOR TOTAL:		78.25

VJ1	VJ WASH & LUBE	05/17/2023	10048	FTB	OIL CHANGE FORD EXPLORER MAY 2023	
112541	827 DEGURSE	06/16/2023		N		35.00
05/17/2023	MARINE CITY MI, 48039	/ /	0.0000	N		0.00
		06/17/2023		N		35.00

Paid

GL NUMBER	DESCRIPTION	AMOUNT
101-301.000-932.000	OIL CHANGE FORD EXPLORER MAY 2023	35.00
VENDOR TOTAL:		35.00

Z002	ZIMMER'S SALES & SERVICE	05/24/2023	116497	FTB	DPW TIRE/VALVE STEM/STIHL TRIMMER	
112526	6667 ST CLAIR HWY	06/16/2023		N		570.49
05/24/2023	CHINA MI, 48054	/ /	0.0000	N		0.00
		06/23/2023		N		570.49

Paid

GL NUMBER	DESCRIPTION	AMOUNT
101-441.000-931.003	DPW TIRE/VALVE STEM/STIHL TRIMMER	570.49
VENDOR TOTAL:		570.49

TOTAL - ALL VENDORS: 268,675.42

User: POSEY

EXP CHECK RUN DATES 07/20/2023 - 07/20/2023

DB: Marine City

JOURNALIZED

OPEN

ENCUMBRANCES - 07/20/23

Vendor Code	Vendor name	Post Date	Invoice	Bank	Invoice Description	Gross Amount
Ref #	Address	CK Run Date	PO	Hold		Discount
Invoice Date	City/State/Zip	Disc. Date	Disc. %	Sep CK		Net Amount
Invoice Notes		Due Date		1099		
A168	AMERICAN LEGAL PUBLISHING CORP	06/30/2023	26560	FTB	JUNE 2023 S7 EDITING	
112709	525 VINE STREET	07/20/2023		N		100.72
	STE. 310					
06/30/2023	CINCINNATI OH, 45202	/ /	0.0000	N		0.00
		07/30/2023		N		100.72

Open

GL NUMBER	DESCRIPTION	AMOUNT
101-215.000-802.000	CONTRACTUAL SERVICES	100.72

A168	AMERICAN LEGAL PUBLISHING CORP	06/30/2023	26638	FTB	JUNE 2023 S7 FOLIO/INTERNET EDITING	
112708	525 VINE STREET	07/20/2023		N		7.80
	STE. 310					
06/30/2023	CINCINNATI OH, 45202	/ /	0.0000	N		0.00
		07/30/2023		N		7.80

Open

GL NUMBER	DESCRIPTION	AMOUNT
101-215.000-802.000	JUNE 2023 S7 FOLIO/INTERNET EDITING	7.80

VENDOR TOTAL: 108.52

A998	ASCENSUS	06/28/2023	STATEMENT	FTB	BENEFIT CALCULATION	
112700	23693 NETWORK PLACE	07/20/2023		N		640.00
06/28/2023	CHICAGO IL, 60673-1236	/ /	0.0000	N		0.00
		07/28/2023		N		640.00

Open

GL NUMBER	DESCRIPTION	AMOUNT
731-000.000-801.000	BENEFIT CALCULATION	640.00

VENDOR TOTAL: 640.00

A997	AUTOZONE, INC	06/29/2023	2181145871	FTB	WINDO- WELD FAST	
112699		07/20/2023		N		69.98
	PO BOX 791409					
06/29/2023	BALTIMORE MD, 21279-1409	/ /	0.0000	N		0.00
		07/28/2023		N		69.98

Open

GL NUMBER	DESCRIPTION	AMOUNT
592-548.000-934.000	WINDO- WELD FAST	69.98

User: POSEY

EXP CHECK RUN DATES 07/20/2023 - 07/20/2023

DB: Marine City

JOURNALIZED

OPEN

ENCUMBRANCES - 07/20/23

Vendor Code	Vendor name	Post Date	Invoice	Bank	Invoice Description	Gross Amount
Ref #	Address	CK Run Date	PO	Hold		Discount
Invoice Date	City/State/Zip	Disc. Date	Disc. %	Sep CK		Net Amount
Invoice Notes		Due Date		1099		

VENDOR TOTAL: 69.98

C252	COMCAST	07/20/2023	STATEMENT	FTB	375 S PARKER ST	
112715	PO BOX 7500	07/20/2023		N		420.38
07/07/2023	SOUTHEASTERN PA, 19398-7500	/ /	0.0000	Y		0.00
		07/28/2023		N		420.38

Open
*7/20-8/19/23

GL NUMBER	DESCRIPTION	AMOUNT
101-301.000-920.000	375 S PARKER ST	420.38

C252	COMCAST	07/21/2023	STATEMENT	FTB	229 S WATER ST WW	
112716	PO BOX 7500	07/20/2023		N		177.99
07/08/2023	SOUTHEASTERN PA, 19398-7500	/ /	0.0000	N		0.00
		07/29/2023		N		177.99

Open
*7/21-8/20/23

GL NUMBER	DESCRIPTION	AMOUNT
592-549.000-850.000	229 S WATER ST WW	177.99

C252	COMCAST	07/14/2023	STATEMENT	FTB	260 S PARKER	
112727	PO BOX 7500	07/20/2023		N		227.02
07/10/2023	SOUTHEASTERN PA, 19398-7500	/ /	0.0000	N		0.00
		07/31/2023		N		227.02

Open
*7/14-8/13/23

GL NUMBER	DESCRIPTION	AMOUNT
101-172.000-850.000	260 S PARKER	37.84
101-257.000-850.000	260 S PARKER	37.84
101-215.000-850.000	260 S PARKER	37.84
101-253.000-850.000	260 S PARKER	37.84
101-371.000-850.000	260 S PARKER	37.84
592-543.000-850.000	260 S PARKER	18.91
592-547.000-850.000	260 S PARKER	18.91
		<u>227.02</u>

VENDOR TOTAL: 825.39

OPEN
 ENCUMBRANCES - 07/20/23

Vendor Code	Vendor name	Post Date	Invoice	Bank	Invoice Description	Gross Amount
Ref #	Address	CK Run Date	PO	Hold		Discount
Invoice Date	City/State/Zip	Disc. Date	Disc. %	Sep CK		Net Amount
Invoice Notes		Due Date		1099		

C022	COTTRELLVILLE TOWNSHIP	06/30/2023	STATEMENT	FTB	QUARTELY SEWER INVOICE 4/1-6/30/2023	
112705	7008 MARSH RD	07/20/2023		N		2,350.00
07/06/2023	MARINE CITY MI, 48039	/ /	0.0000	N		0.00
		08/06/2023		N		2,350.00

Open

GL NUMBER	DESCRIPTION	AMOUNT
592-543.000-802.000	QUARTELY SEWER INVOICE 4/1-6/30/2023	2,350.00
VENDOR TOTAL:		2,350.00

D997	DEPATIE FLUID POWER	06/02/2023	10230335	FTB	CYLINDER DPW	
112693	6256 AMERICAN AVE	07/20/2023		N		259.52
06/06/2023	PORTAGE MI, 49002	/ /	0.0000	N		0.00
		07/06/2023		N		259.52

Open

GL NUMBER	DESCRIPTION	AMOUNT
101-441.000-931.003	CYLINDER DPW	259.52
VENDOR TOTAL:		259.52

E083	ECONOMIC DEVELOPMENT ALLIANCE	07/01/2023	6517	FTB	ANNUAL MEMBERSHIP JULY 1 2023- JUNE 30	
112711	735 ERIE STREET SUITE 250	07/20/2023		N		2,124.00
07/01/2023	PORT HURON MI, 48060	/ /	0.0000	N		0.00
		07/30/2023		N		2,124.00

Open

GL NUMBER	DESCRIPTION	AMOUNT
101-101.000-915.000	ANNUAL MEMBERSHIP JULY 1 2023- JUNE 30 2	2,124.00
VENDOR TOTAL:		2,124.00

E220	ELECTRIC MOTOR SERVICES, LLC	06/23/2023	8657	FTB	ELECTRIC MOTOR	
112697	3340 LAPEER RD	07/20/2023		N		295.52
06/23/2023	PORT HURON MI, 48060	/ /	0.0000	N		0.00
		07/23/2023		N		295.52

Open

GL NUMBER	DESCRIPTION	AMOUNT
592-545.000-934.000	ELECTRIC MOTOR	295.52

JOURNALIZED

OPEN

ENCUMBRANCES - 07/20/23

Vendor Code	Vendor name	Post Date	Invoice	Bank	Invoice Description	Gross Amount
Ref #	Address	CK Run Date	PO	Hold		Discount
Invoice Date	City/State/Zip	Disc. Date	Disc. %	Sep CK		Net Amount
Invoice Notes		Due Date		1099		

VENDOR TOTAL: 295.52

E086	EMTERRA ENVIRONMENTAL USA CORP	05/31/2023	49359	FTB	FUEL JUNE 2023	
112594	1606 E WEBSTER ROAD	07/20/2023		N		315.00
05/31/2023	FLINT MI, 48505	/ /	0.0000	N		0.00
		07/30/2023		N		315.00

Open

GL NUMBER	DESCRIPTION	AMOUNT
101-528.000-802.000	FUEL	315.00

E086	EMTERRA ENVIRONMENTAL USA CORP	06/30/2023	54224	FTB	TRASH & RECYCLING/LANDFILL FEE 6/2023	
112593	1606 E WEBSTER ROAD	07/20/2023		N		25,380.84
06/01/2023	FLINT MI, 48505	/ /	0.0000	N		0.00
		07/31/2023		N		25,380.84

Open

GL NUMBER	DESCRIPTION	AMOUNT
101-528.000-802.000	TRASH RECYCLING JUNE 2023	25,168.26
101-528.000-802.000	CONTRACTUAL SERVICES JUNE 2023	141.66
101-528.000-802.000	MICHIGAN LF FEE JUNE 2023	70.92
		<u>25,380.84</u>

E086	EMTERRA ENVIRONMENTAL USA CORP	06/30/2023	66489	FTB	FUEL JUNE 2023	
112710	1606 E WEBSTER ROAD	07/20/2023		N		236.25
06/30/2023	FLINT MI, 48505	/ /	0.0000	N		0.00
		07/30/2023		N		236.25

Open

GL NUMBER	DESCRIPTION	AMOUNT
101-528.000-802.000	FUEL JUNE 2023	236.25

VENDOR TOTAL: 25,932.09

E007	ETNA SUPPLY COMPANY	06/13/2023	S105140783.001	FTB	REPAIR CLAMP	
112682	PO BOX 772107	07/20/2023		N		624.00
06/13/2023	DETROIT MI, 48277-2107	/ /	0.0000	N		0.00
		06/25/2023		N		624.00

Open

User: POSEY

EXP CHECK RUN DATES 07/20/2023 - 07/20/2023

DB: Marine City

JOURNALIZED

OPEN

ENCUMBRANCES - 07/20/23

Vendor Code	Vendor name	Post Date	Invoice	Bank	Invoice Description	Gross Amount
Ref #	Address	CK Run Date	PO	Hold		Discount
Invoice Date	City/State/Zip	Disc. Date	Disc. %	Sep CK		Net Amount
Invoice Notes		Due Date		1099		

GL NUMBER	DESCRIPTION	AMOUNT
592-545.000-934.000	REPAIR CLAMP	624.00

VENDOR TOTAL: 624.00

E150	EVOQUA WATER TECHNOLOGIES	12/19/2022	STATEMENT	FTB	BEARING- FROM OCT 2022 INVOICE	
112714	N19W23993 RIDGEVIEW PKWY, SUITE 200	07/20/2023		N		2,802.01
10/28/2022	WAUKESHA WI, 53188	/ /	0.0000	N		0.00
		11/28/2022		N		2,802.01

Open
*LATE INVOICE NEVER PAID

GL NUMBER	DESCRIPTION	AMOUNT
592-545.000-931.003	BEARING- FROM OCT 2022 INVOICE	2,802.01

VENDOR TOTAL: 2,802.01

V024	FLAGSHIP-VISA	06/12/2023	STATEMENT	FTB	VISA 4254/AMAZON 2 USB FLASHDRIVE 64GB	
112729	3910 LAPEER RD	07/20/2023		N		59.62
06/12/2023	PORT HURON MI, 48060-2402	/ /	0.0000	N		0.00
		07/27/2023		N		59.62

Open

GL NUMBER	DESCRIPTION	AMOUNT
101-301.000-755.000	VISA 4254/AMAZON 2 USB FLASHDRIVE 64GB	59.62

V024	FLAGSHIP-VISA	06/13/2023	STATEMENT	FTB	VISA 4254/AMAZON USB TO HDMI/STICKY NOT	
112730	3910 LAPEER RD	07/20/2023		N		86.87
06/13/2023	PORT HURON MI, 48060-2402	/ /	0.0000	N		0.00
		07/27/2023		N		86.87

Open

GL NUMBER	DESCRIPTION	AMOUNT
101-301.000-755.000	VISA 4254/AMAZON USB TO HDMI/STICKY NOTE	8.89
101-301.000-755.000	VISA 4254/AMAZON STICKY NOTES	18.00
101-441.000-755.000	VISA 4254/AMAZON SHARPIE X2	59.98
		<u>86.87</u>

V024	FLAGSHIP-VISA	06/21/2023	STATEMENT	FTB	VISA 4254/AMAZON TOSHIBA AIRFRYER/FIRE	
112731	3910 LAPEER RD	07/20/2023		N		482.94
06/21/2023	PORT HURON MI, 48060-2402	/ /	0.0000	N		0.00

OPEN
ENCUMBRANCES - 07/20/23

Vendor Code	Vendor name	Post Date	Invoice	Bank	Invoice Description	Gross Amount
Ref #	Address	CK Run Date	PO	Hold		Discount
Invoice Date	City/State/Zip	Disc. Date	Disc. %	Sep CK		Net Amount
Invoice Notes		Due Date		1099		
		07/27/2023		N		482.94

Open

GL NUMBER	DESCRIPTION	AMOUNT
101-301.000-756.000	VISA 4254/AMAZON TOSHIBA AIR FRYER MICRO	198.00
101-301.000-756.000	VISA 4254/AMAZON FRIE TV 43"	259.99
101-301.000-756.000	VISA 4254/AMAZON MILITARY COIN DISPLAY	24.95
		<u>482.94</u>

V024	FLAGSHIP-VISA	06/06/2023	STATEMENT	FTB	VISA 8545/AMAZON SPONGE	
112732	3910 LAPEER RD	07/20/2023		N		6.64
06/06/2023	PORT HURON MI, 48060-2402	/ /	0.0000	N		0.00
		07/27/2023		N		6.64

Open

GL NUMBER	DESCRIPTION	AMOUNT
101-215.000-755.000	AMAZON SPONGE	1.11
101-253.000-755.000	AMAZON SPONGE	1.11
101-172.000-755.000	AMAZON SPONGE	1.11
101-257.000-755.000	AMAZON SPONGE	1.11
101-371.000-755.000	AMAZON SPONGE	1.11
592-543.000-755.000	AMAZON SPONGE	0.55
592-547.000-755.000	AMAZON SPONGE	0.54
		<u>6.64</u>

V024	FLAGSHIP-VISA	06/06/2023	STATEMENT	FTB	VISA 8545/AMAZON HAND SOAP/STAMP/CALC/D	
112733	3910 LAPEER RD	07/20/2023		N		130.17
06/06/2023	PORT HURON MI, 48060-2402	/ /	0.0000	N		0.00
		07/27/2023		N		130.17

Open

GL NUMBER	DESCRIPTION	AMOUNT
101-441.000-752.000	VISA 8545 AMAZON HAND SOAP	8.99
101-215.000-755.000	VISA 8545 AMAZON DATE STAMP	2.91
101-253.000-755.000	VISA 8545 AMAZON DATE STAMP	2.91
101-172.000-755.000	VISA 8545 AMAZON DATE STAMP	2.91
101-257.000-755.000	VISA 8545 AMAZON DATE STAMP	2.91
101-371.000-755.000	VISA 8545 AMAZON DATE STAMP	2.91
592-543.000-755.000	VISA 8545 AMAZON DATE STAMP	1.45
592-547.000-755.000	VISA 8545 AMAZON DATE STAMP	1.45

JOURNALIZED

OPEN

ENCUMBRANCES - 07/20/23

Vendor Code	Vendor name	Post Date	Invoice	Bank	Invoice Description	Gross Amount
Ref #	Address	CK Run Date	PO	Hold		Discount
Invoice Date	City/State/Zip	Disc. Date	Disc. %	Sep CK		Net Amount
Invoice Notes		Due Date		1099		

101-253.000-755.000	VISA 8545 AMAZON CALCULATOR					42.99
101-756.000-752.000	VISA 8545 AMAZON DEODORIZER					23.97
101-441.000-752.000	VISA 8545 AMAZON HAND SOAP					19.59
101-441.000-752.000	VISA 8545 AMAZON NOTE PAD					17.18
						130.17

V024	FLAGSHIP-VISA	06/21/2023	STATEMENT	FTB	VISA 8545 AMAZON STAPLER/CORD/TOWELS/TP	
112734	3910 LAPEER RD	07/20/2023		N		244.86
06/21/2023	PORT HURON MI, 48060-2402	/ /	0.0000	N		0.00
		07/27/2023		N		244.86

Open

GL NUMBER	DESCRIPTION	AMOUNT
101-215.000-755.000	8545 AMAZON STAPLER/TOWELS/NAPKINS/CORD	15.17
101-253.000-755.000	8545 AMAZON STAPLER/TOWELS/NAPKINS/CORD	15.17
101-172.000-755.000	8545 AMAZON STAPLER/TOWELS/NAPKINS/CORD	15.17
101-257.000-755.000	8545 AMAZON STAPLER/TOWELS/NAPKINS/CORD	15.17
101-371.000-755.000	8545 AMAZON STAPLER/TOWELS/NAPKINS/CORD	15.17
592-543.000-755.000	8545 AMAZON STAPLER/TOWELS/NAPKINS/CORD	7.59
592-547.000-755.000	8545 AMAZON STAPLER/TOWELS/NAPKINS/CORD	7.60
101-265.000-752.000	VISA 8545 AMAZON TP HOLDER/TP STAND	30.66
592-549.000-755.000	VISA 8545 AMAZON HP TONER	116.89
101-371.000-755.000	VISA 8545 AMAZON DISPLAY PORT	6.27
		244.86

V024	FLAGSHIP-VISA	06/08/2023	STATEMENT	FTB	VISA 4254/AMAZON GUN CLEANING PATCH/VGA	
112712	3910 LAPEER RD	07/20/2023		N		15.54
06/08/2023	PORT HURON MI, 48060-2402	/ /	0.0000	N		0.00
		07/27/2023		N		15.54

Open

GL NUMBER	DESCRIPTION	AMOUNT
101-301.000-755.000	AMAZON GUN CLEANING PATCH	7.99
101-441.000-755.000	AMAZON VGA SPLITTER	7.55
		15.54

V024	FLAGSHIP-VISA	06/28/2023	STATEMENT	FTB	VISA 8545 AMAZON WEB CAM	
112713	3910 LAPEER RD	07/20/2023		N		21.99
06/28/2023	PORT HURON MI, 48060-2402	/ /	0.0000	N		0.00
		07/27/2023		N		21.99

JOURNALIZED

OPEN

ENCUMBRANCES - 07/20/23

Vendor Code	Vendor name	Post Date	Invoice	Bank	Invoice Description	Gross Amount
Ref #	Address	CK Run Date	PO	Hold		Discount
Invoice Date	City/State/Zip	Disc. Date	Disc. %	Sep CK		Net Amount
Invoice Notes		Due Date		1099		

Open

GL NUMBER	DESCRIPTION	AMOUNT
101-441.000-755.000	WEB CAMVISA 8545 AMAZON WEB CAM	21.99
VENDOR TOTAL:		1,048.63

H101	HAVILAND PRODUCTS COMPANY	06/22/2023	475080	FTB	WWTP BLEACH	
112680	421 ANN STREET NW	07/20/2023		N		1,440.00
06/22/2023	GRAND RAPIDS MI, 49504-2075	/ /	0.0000	N		0.00
		07/22/2023		N		1,440.00

Open

GL NUMBER	DESCRIPTION	AMOUNT
592-545.000-753.001	WWTP BLEACH	1,440.00
VENDOR TOTAL:		1,440.00

K076	KCA SERVICES	07/07/2023	4	FTB	307 WARD REMOVED 1 DEAD TREE/TRIMMED TR	
112701	2530 PALMS ROAD	07/20/2023		N		400.00
07/07/2023	COLUMBUS MI, 48063	/ /	0.0000	N		0.00
		07/31/2023		Y		400.00

Open

GL NUMBER	DESCRIPTION	AMOUNT
101-271.000-802.000	307 WARD REMOVED 1 DEAD TREE/TRIMMED TRE	400.00

K076	KCA SERVICES	07/07/2023	5	FTB	331 N MAIN ST REMOVED 1 TREE/HAUL/GROUN	
112702	2530 PALMS ROAD	07/20/2023		N		400.00
07/07/2023	COLUMBUS MI, 48063	/ /	0.0000	N		0.00
		07/28/2023		Y		400.00

Open

GL NUMBER	DESCRIPTION	AMOUNT
101-271.000-802.000	331 N MAIN ST REMOVED 1 TREE/HAUL/GROUND	400.00

VENDOR TOTAL:		800.00
----------------------	--	---------------

K125	KERR PUMP AND SUPPLY, INC.	06/21/2023	222151	FTB	SERVICE CONTROL PANEL EMERGENCY REPAIRS	
112698	DRAWER 64185	07/20/2023		N		2,870.00
06/29/2023	DETROIT MI, 48264	/ /	0.0000	N		0.00

User: POSEY
DB: Marine City

EXP CHECK RUN DATES 07/20/2023 - 07/20/2023

JOURNALIZED

OPEN

ENCUMBRANCES - 07/20/23

Vendor Code	Vendor name	Post Date	Invoice	Bank	Invoice Description	Gross Amount
Ref #	Address	CK Run Date	PO	Hold		Discount
Invoice Date	City/State/Zip	Disc. Date	Disc. %	Sep CK		Net Amount
Invoice Notes		Due Date		1099		

		07/29/2023		N		2,870.00
--	--	------------	--	---	--	----------

Open

GL NUMBER	DESCRIPTION	AMOUNT
592-548.000-934.000	SERVICE CONTROL PANEL EMERGENCY REPAIRS	2,870.00

VENDOR TOTAL: 2,870.00

L006	LUMBERJACK BUILDING CENTERS INC.	05/30/2023	E67171	FTB	DOCK REPAIR BULK FASTENER	
112657	CAPITAL ONE TRADE CREDIT	07/20/2023		N		12.76
	PO BOX 105525					
05/30/2023	ATLANTA GA, 30348-5525	/ /	0.0000	N		0.00
		07/10/2023		N		12.76

Open

GL NUMBER	DESCRIPTION	AMOUNT
101-265.000-930.000	DOCK REPAIR BULK FASTENER	12.76

L006	LUMBERJACK BUILDING CENTERS INC.	05/31/2023	E67437	FTB	WWTP PENETRATING SPRAY	
112658	CAPITAL ONE TRADE CREDIT	07/20/2023		N		15.18
	PO BOX 105525					
05/31/2023	ATLANTA GA, 30348-5525	/ /	0.0000	N		0.00
		07/10/2023		N		15.18

Open

GL NUMBER	DESCRIPTION	AMOUNT
101-441.000-931.003	WWTP PENETRATING SPRAY	15.18

L006	LUMBERJACK BUILDING CENTERS INC.	06/01/2023	E67787	FTB	PAVILLION BATHROOMS SINK SUPPLY	
112659	CAPITAL ONE TRADE CREDIT	07/20/2023		N		8.54
	PO BOX 105525					
06/01/2023	ATLANTA GA, 30348-5525	/ /	0.0000	N		0.00
		07/10/2023		N		8.54

Open

GL NUMBER	DESCRIPTION	AMOUNT
101-756.000-930.000	PAVILLION BATHROOMS SINK SUPPLY	8.54

L006	LUMBERJACK BUILDING CENTERS INC.	06/07/2023	E70012	FTB	KING PARK RD CONCRETE MIX	
112661	CAPITAL ONE TRADE CREDIT	07/20/2023		N		11.98
	PO BOX 105525					
06/07/2023	ATLANTA GA, 30348-5525	/ /	0.0000	N		0.00

User: POSEY

EXP CHECK RUN DATES 07/20/2023 - 07/20/2023

DB: Marine City

JOURNALIZED

OPEN

ENCUMBRANCES - 07/20/23

Vendor Code	Vendor name	Post Date	Invoice	Bank	Invoice Description	Gross Amount
Ref #	Address	CK Run Date	PO	Hold		Discount
Invoice Date	City/State/Zip	Disc. Date	Disc. %	Sep CK		Net Amount
Invoice Notes		Due Date		1099		

		07/10/2023		N		11.98
--	--	------------	--	---	--	-------

Open

GL NUMBER	DESCRIPTION	AMOUNT
101-756.000-752.000	KING PARK RD CONCRETE MIX	11.98

L006	LUMBERJACK BUILDING CENTERS INC.	06/07/2023	E70046	FTB	KING RD PARK COIL	
112662	CAPITAL ONE TRADE CREDIT	07/20/2023		N		115.23
	PO BOX 105525					
06/07/2023	ATLANTA GA, 30348-5525	/ /	0.0000	N		0.00
		07/10/2023		N		115.23

Open

GL NUMBER	DESCRIPTION	AMOUNT
101-756.000-752.000	KING RD PARK COIL	115.23

L006	LUMBERJACK BUILDING CENTERS INC.	06/07/2023	E70054	FTB	KING RD PARK PADLOCK	
112663	CAPITAL ONE TRADE CREDIT	07/20/2023		N		15.19
	PO BOX 105525					
06/07/2023	ATLANTA GA, 30348-5525	/ /	0.0000	N		0.00
		07/10/2023		N		15.19

Open

GL NUMBER	DESCRIPTION	AMOUNT
101-756.000-752.000	KING RD PARK PADLOCK	15.19

L006	LUMBERJACK BUILDING CENTERS INC.	06/07/2023	E70155	FTB	KING RD PARK SPF	
112664	CAPITAL ONE TRADE CREDIT	07/20/2023		N		11.10
	PO BOX 105525					
06/07/2023	ATLANTA GA, 30348-5525	/ /	0.0000	N		0.00
		07/10/2023		N		11.10

Open

GL NUMBER	DESCRIPTION	AMOUNT
101-756.000-752.000	KING RD PARK SPF	11.10

L006	LUMBERJACK BUILDING CENTERS INC.	06/08/2023	E70401	FTB	HOSE	
112665	CAPITAL ONE TRADE CREDIT	07/20/2023		N		50.34
	PO BOX 105525					
06/08/2023	ATLANTA GA, 30348-5525	/ /	0.0000	N		0.00
		07/10/2023		N		50.34

Open

User: POSEY
DB: Marine City

EXP CHECK RUN DATES 07/20/2023 - 07/20/2023

JOURNALIZED

OPEN

ENCUMBRANCES - 07/20/23

Vendor Code	Vendor name	Post Date	Invoice	Bank	Invoice Description	Gross Amount
Ref #	Address	CK Run Date	PO	Hold		Discount
Invoice Date	City/State/Zip	Disc. Date	Disc. %	Sep CK		Net Amount
Invoice Notes		Due Date		1099		

GL NUMBER	DESCRIPTION	AMOUNT
101-756.000-752.000	HOSE	50.34
L006	LUMBERJACK BUILDING CENTERS INC.	06/08/2023 E70402 FTB PARKS GRASS SEED
112666	CAPITAL ONE TRADE CREDIT	07/20/2023 N 75.99
	PO BOX 105525	
06/08/2023	ATLANTA GA, 30348-5525	/ / 0.0000 N 0.00
		07/10/2023 N 75.99

Open

GL NUMBER	DESCRIPTION	AMOUNT
101-756.000-752.000	PARKS GRASS SEED	75.99
L006	LUMBERJACK BUILDING CENTERS INC.	06/13/2023 E71866 FTB IRRIGATION WOMENS CIVIC
112667	CAPITAL ONE TRADE CREDIT	07/20/2023 N 25.86
	PO BOX 105525	
06/13/2023	ATLANTA GA, 30348-5525	/ / 0.0000 N 0.00
		07/10/2023 N 25.86

Open

GL NUMBER	DESCRIPTION	AMOUNT
101-756.000-752.000	IRRIGATION WOMENS CIVIC	25.86
L006	LUMBERJACK BUILDING CENTERS INC.	06/13/2023 E71876 FTB IRRIGATION WOMENS CIVIC
112668	CAPITAL ONE TRADE CREDIT	07/20/2023 N 14.00
	PO BOX 105525	
06/13/2023	ATLANTA GA, 30348-5525	/ / 0.0000 N 0.00
		07/10/2023 N 14.00

Open

GL NUMBER	DESCRIPTION	AMOUNT
101-756.000-752.000	IRRIGATION WOMENS CIVIC	14.00
L006	LUMBERJACK BUILDING CENTERS INC.	06/13/2023 E71940 FTB CARB SPRAY
112669	CAPITAL ONE TRADE CREDIT	07/20/2023 N 5.69
	PO BOX 105525	
06/13/2023	ATLANTA GA, 30348-5525	/ / 0.0000 N 0.00
		07/10/2023 N 5.69

Open

GL NUMBER	DESCRIPTION	AMOUNT
-----------	-------------	--------

07/12/2023 04:07 PM
 User: POSEY
 DB: Marine City

INVOICE APPROVAL BY INVOICE REPORT FOR CITY OF MARINE CITY
 EXP CHECK RUN DATES 07/20/2023 - 07/20/2023
 JOURNALIZED

OPEN
 ENCUMBRANCES - 07/20/23

Vendor Code	Vendor name	Post Date	Invoice	Bank	Invoice Description	Gross Amount
Ref #	Address	CK Run Date	PO	Hold		Discount
Invoice Date	City/State/Zip	Disc. Date	Disc. %	Sep CK		Net Amount
Invoice Notes		Due Date		1099		

101-441.000-931.003	CARB SPRAY					5.69
L006	LUMBERJACK BUILDING CENTERS INC.	06/14/2023	E72222	FTB	KEYS FOR GATE/ GRASS SEED	
112670	CAPITAL ONE TRADE CREDIT	07/20/2023		N		85.44
	PO BOX 105525					
06/14/2023	ATLANTA GA, 30348-5525	/ /	0.0000	N		0.00
		07/10/2023		N		85.44

Open

GL NUMBER	DESCRIPTION	AMOUNT
101-756.000-752.000	KEYS FOR GATE/ GRASS SEED	85.44

L006	LUMBERJACK BUILDING CENTERS INC.	06/15/2023	E72430	FTB	260 S PARKER LIGHT POLE COVER	
112671	CAPITAL ONE TRADE CREDIT	07/20/2023		N		2.65
	PO BOX 105525					
06/15/2023	ATLANTA GA, 30348-5525	/ /	0.0000	N		0.00
		07/10/2023		N		2.65

Open

GL NUMBER	DESCRIPTION	AMOUNT
101-756.000-752.000	260 S PARKER LIGHT POLE	2.65

L006	LUMBERJACK BUILDING CENTERS INC.	06/20/2023	E73931	FTB	DPW MNR FRK	
112672	CAPITAL ONE TRADE CREDIT	07/20/2023		N		45.59
	PO BOX 105525					
06/20/2023	ATLANTA GA, 30348-5525	/ /	0.0000	N		0.00
		07/10/2023		N		45.59

Open

GL NUMBER	DESCRIPTION	AMOUNT
101-441.000-931.003	DPW MNR FRK	45.59

L006	LUMBERJACK BUILDING CENTERS INC.	06/20/2023	E74084	FTB	2.5 GALLON MIX	
112673	CAPITAL ONE TRADE CREDIT	07/20/2023		N		23.76
	PO BOX 105525					
06/20/2023	ATLANTA GA, 30348-5525	/ /	0.0000	N		0.00
		07/10/2023		N		23.76

Open

GL NUMBER	DESCRIPTION	AMOUNT
101-756.000-752.000	2.5 GALLON MIX	23.76

User: POSEY

EXP CHECK RUN DATES 07/20/2023 - 07/20/2023

DB: Marine City

JOURNALIZED

OPEN

ENCUMBRANCES - 07/20/23

Vendor Code	Vendor name	Post Date	Invoice	Bank	Invoice Description	Gross Amount
Ref #	Address	CK Run Date	PO	Hold		Discount
Invoice Date	City/State/Zip	Disc. Date	Disc. %	Sep CK		Net Amount
Invoice Notes		Due Date		1099		

L006	LUMBERJACK BUILDING CENTERS INC.	06/22/2023	E74719	FTB	SIGN FOR BOAT DOCK BULK FASTENER	
112674	CAPITAL ONE TRADE CREDIT	07/20/2023		N		127.40
	PO BOX 105525					
06/22/2023	ATLANTA GA, 30348-5525	/ /	0.0000	N		0.00
		07/10/2023		N		127.40

Open

GL NUMBER	DESCRIPTION	AMOUNT
101-756.000-934.000	SIGN FOR BOAT DOCK BULK FASTENER	127.40

L006	LUMBERJACK BUILDING CENTERS INC.	06/23/2023	E74873	FTB	REPAIRS WWTP	
112675	CAPITAL ONE TRADE CREDIT	07/20/2023		N		16.30
	PO BOX 105525					
06/23/2023	ATLANTA GA, 30348-5525	/ /	0.0000	N		0.00
		07/10/2023		N		16.30

Open

GL NUMBER	DESCRIPTION	AMOUNT
592-546.000-931.003	REPAIRS WWTP	16.30

L006	LUMBERJACK BUILDING CENTERS INC.	06/23/2023	E74911	FTB	WWTP BULK FASTENERS	
112676	CAPITAL ONE TRADE CREDIT	07/20/2023		N		16.34
	PO BOX 105525					
06/23/2023	ATLANTA GA, 30348-5525	/ /	0.0000	N		0.00
		07/10/2023		N		16.34

Open

GL NUMBER	DESCRIPTION	AMOUNT
592-546.000-931.003	WWTP BULK FASTENERS	16.34

L006	LUMBERJACK BUILDING CENTERS INC.	06/23/2023	E74950	FTB	PRESSURE WASHER COUPLER	
112677	CAPITAL ONE TRADE CREDIT	07/20/2023		N		14.24
	PO BOX 105525					
06/23/2023	ATLANTA GA, 30348-5525	/ /	0.0000	N		0.00
		07/10/2023		N		14.24

Open

GL NUMBER	DESCRIPTION	AMOUNT
101-441.000-934.000	PRESSURE WASHER COUPLER	14.24

L006	LUMBERJACK BUILDING CENTERS INC.	06/02/2023	L006	FTB	IRRIGATION PVC CAP	
------	----------------------------------	------------	------	-----	--------------------	--

User: POSEY

EXP CHECK RUN DATES 07/20/2023 - 07/20/2023

DB: Marine City

JOURNALIZED

OPEN

ENCUMBRANCES - 07/20/23

Vendor Code	Vendor name	Post Date	Invoice	Bank	Invoice Description	Gross Amount
Ref #	Address	CK Run Date	PO	Hold		Discount
Invoice Date	City/State/Zip	Disc. Date	Disc. %	Sep CK		Net Amount
Invoice Notes		Due Date		1099		
112660	CAPITAL ONE TRADE CREDIT	07/20/2023		N		2.08
	PO BOX 105525					
06/02/2023	ATLANTA GA, 30348-5525	/ /	0.0000	N		0.00
		07/10/2023		N		2.08

Open

GL NUMBER	DESCRIPTION	AMOUNT
101-756.000-934.000	IRRIGATION PVC CAP	2.08

VENDOR TOTAL: 695.66

M377	MARK R. SCHWARTZ	06/30/2023	STATEMENT	FTB	ELECTRICAL INSPECTIONS JUNE 2023	
112696	9821 SPRINGBORN	07/20/2023		N		215.25
07/01/2023	CASCO MI, 48064	/ /	0.0000	N		0.00
		07/31/2023		Y		215.25

Open

*263 N BELLE RIVER
424 RIVER VALLEY

GL NUMBER	DESCRIPTION	AMOUNT
101-371.000-802.000	ELECTRICAL INSPECTIONS JUNE 2023	215.25

VENDOR TOTAL: 215.25

M143	MICHIGAN RURAL WATER ASSN	07/01/2023	2020-07641	FTB	ANNUAL DUES ENTIRE COMMUNITY	
112529	2127 UNIVERSITY PARK DR. STE 340	07/20/2023		N		535.00
07/01/2023	OKEMOS MI, 48864	/ /	0.0000	N		0.00
		07/30/2023		N		535.00

Open

GL NUMBER	DESCRIPTION	AMOUNT
101-441.000-915.000	ANNUAL DUES ENTIRE COMMUNITY	133.75
592-544.000-915.000	ANNUAL DUES ENTIRE COMMUNITY	133.75
592-545.000-915.000	ANNUAL DUES ENTIRE COMMUNITY	133.75
592-548.000-915.000	ANNUAL DUES ENTIRE COMMUNITY	133.75
		535.00

VENDOR TOTAL: 535.00

N084	NICKEL & SAPH INC	07/01/2023	22737	FTB	MEM PCKG ANNUAL RENEWAL PREMIUM	
112704	PO BOX 46907	07/20/2023		N		133,570.00

JOURNALIZED

OPEN

ENCUMBRANCES - 07/20/23

Vendor Code	Vendor name	Post Date	Invoice	Bank	Invoice Description	Gross Amount
Ref #	Address	CK Run Date	PO	Hold		Discount
Invoice Date	City/State/Zip	Disc. Date	Disc. %	Sep CK		Net Amount
Invoice Notes		Due Date		1099		
06/24/2023	MOUNT CLEMENS MI, 48046-6907	/ /	0.0000	N		0.00
		07/01/2023		N		133,570.00

Open

GL NUMBER	DESCRIPTION	AMOUNT
101-270.000-935.000	MEM PCKG ANNUAL RENEWAL PREMIUM	133,570.00

VENDOR TOTAL: 133,570.00

R012	RAYMOND JAMES & ASSOCIATES	07/01/2023	STATEMENT	FTB	EMPLOYER RETIREMENT CONTRIBUTION 07/202	
112728	691 N SQUIRREL RD SUITE 222	07/20/2023		N		37,059.59
07/01/2023	AUBURN HILLS MI, 48326	/ /	0.0000	N		0.00
		07/31/2023		N		37,059.59

Open

*JULY 2023 EMPLOYER RETIREMENT CONTRIBUTION

GL NUMBER	DESCRIPTION	AMOUNT
101-270.000-717.001	EMPLOYER RETIREMENT CONTRIBUTION 07/2023	22,975.43
202-450.000-717.001	EMPLOYER RETIREMENT CONTRIBUTION 07/2023	1,112.49
203-450.000-717.001	EMPLOYER RETIREMENT CONTRIBUTION 07/2023	2,223.32
209-000.000-717.001	EMPLOYER RETIREMENT CONTRIBUTION 07/2023	742.93
592-543.000-717.001	EMPLOYER RETIREMENT CONTRIBUTION 07/2023	4,076.26
592-547.000-717.001	EMPLOYER RETIREMENT CONTRIBUTION 07/2023	5,929.16

37,059.59

VENDOR TOTAL: 37,059.59

S012	SEMCO ENERGY GAS CO	06/27/2023	STATEMENT	FTB	300 BROADWAY	
112717	PO BOX 740812	07/20/2023		N		17.55
06/27/2023	CINCINNATI OH, 45274-0812	/ /	0.0000	N		0.00
		07/27/2023		N		17.55

Open

*5/24-6/27/23

GL NUMBER	DESCRIPTION	AMOUNT
101-265.000-921.002	300 BROADWAY	17.55

S012	SEMCO ENERGY GAS CO	06/28/2023	STATEMENT	FTB	304 S BELLE RIVER AVE	
112718	PO BOX 740812	07/20/2023		N		40.32
06/28/2023	CINCINNATI OH, 45274-0812	/ /	0.0000	N		0.00
		07/28/2023		N		40.32

JOURNALIZED

OPEN

ENCUMBRANCES - 07/20/23

Vendor Code	Vendor name	Post Date	Invoice	Bank	Invoice Description	Gross Amount
Ref #	Address	CK Run Date	PO	Hold		Discount
Invoice Date	City/State/Zip	Disc. Date	Disc. %	Sep CK		Net Amount
Invoice Notes		Due Date		1099		

Open
*5/25-6/28/23

GL NUMBER	DESCRIPTION	AMOUNT
592-546.000-921.002	304 S BELLE RIVER AVE	40.32
S012	SEMCO ENERGY GAS CO	06/28/2023
112719	PO BOX 740812	07/20/2023
06/28/2023	CINCINNATI OH, 45274-0812	/ /
		0.0000
		07/28/2023
		260 S PARKER A
		26.08
		0.00
		26.08

Open
*5/25-6/28/23

GL NUMBER	DESCRIPTION	AMOUNT
101-265.000-921.002	260 S PARKER A	26.08
S012	SEMCO ENERGY GAS CO	06/28/2023
112720	PO BOX 740812	07/20/2023
06/28/2023	CINCINNATI OH, 45274-0812	/ /
		0.0000
		07/28/2023
		300 S PARKER ST LIBRARY
		22.31
		0.00
		22.31

Open
*5/25-6/28/23

GL NUMBER	DESCRIPTION	AMOUNT
101-790.000-921.002	300 S PARKER ST LIBRARY	22.31
S012	SEMCO ENERGY GAS CO	06/28/2023
112721	PO BOX 740812	07/20/2023
06/28/2023	CINCINNATI OH, 45274-0812	/ /
		0.0000
		07/28/2023
		375 S PARKER ST
		27.99
		0.00
		27.99

Open
*5/25-6/28/23

GL NUMBER	DESCRIPTION	AMOUNT
101-301.000-921.002	375 S PARKER ST	27.99
S012	SEMCO ENERGY GAS CO	06/28/2023
112722	PO BOX 740812	07/20/2023
06/28/2023	CINCINNATI OH, 45274-0812	/ /
		0.0000
		07/28/2023
		514 S PARKER ST
		79.22
		0.00
		79.22

Open
*5/25-6/28/23

JOURNALIZED

OPEN

ENCUMBRANCES - 07/20/23

Vendor Code	Vendor name	Post Date	Invoice	Bank	Invoice Description	Gross Amount
Ref #	Address	CK Run Date	PO	Hold		Discount
Invoice Date	City/State/Zip	Disc. Date	Disc. %	Sep CK		Net Amount
Invoice Notes		Due Date		1099		

GL NUMBER	DESCRIPTION	AMOUNT
101-441.000-921.002	514 S PARKER ST	79.22
S012	SEMCO ENERGY GAS CO	06/28/2023
112723	PO BOX 740812	07/20/2023
06/28/2023	CINCINNATI OH, 45274-0812	/ /
		0.0000
		07/28/2023
		FTB
		1696 S PARKER ST
		N
		73.80
		N
		0.00
		N
		73.80

Open
 *5/25-6/28/23

GL NUMBER	DESCRIPTION	AMOUNT
592-545.000-921.002	1696 S PARKER ST	73.80
S012	SEMCO ENERGY GAS CO	06/27/2023
112724	PO BOX 740812	07/20/2023
06/27/2023	CINCINNATI OH, 45274-0812	/ /
		0.0000
		07/27/2023
		FTB
		405 S MAIN ST
		N
		27.99
		N
		0.00
		N
		27.99

Open

GL NUMBER	DESCRIPTION	AMOUNT
101-804.000-921.002	405 S MAIN ST	27.99
S012	SEMCO ENERGY GAS CO	06/27/2023
112725	PO BOX 740812	07/20/2023
06/27/2023	CINCINNATI OH, 45274-0812	/ /
		0.0000
		07/27/2023
		FTB
		229 S WATER ST
		N
		23.24
		N
		0.00
		N
		23.24

Open
 *5/24-6/27/23

GL NUMBER	DESCRIPTION	AMOUNT
592-549.000-921.002	229 S WATER ST	23.24
S012	SEMCO ENERGY GAS CO	06/27/2023
112726	PO BOX 740812	07/20/2023
06/27/2023	CINCINNATI OH, 45274-0812	/ /
		0.0000
		07/27/2023
		FTB
		231 S WATER ST
		N
		125.11
		N
		0.00
		N
		125.11

Open
 *5/24-6/27/23

GL NUMBER	DESCRIPTION	AMOUNT
592-549.000-921.002	231 S WATER ST	125.11

OPEN
 ENCUMBRANCES - 07/20/23

Vendor Code	Vendor name	Post Date	Invoice	Bank	Invoice Description	Gross Amount
Ref #	Address	CK Run Date	PO	Hold		Discount
Invoice Date	City/State/Zip	Disc. Date	Disc. %	Sep CK		Net Amount
Invoice Notes		Due Date		1099		

VENDOR TOTAL: 463.61

S157	SIDELINE ELECTRIC	06/06/2023	2016	FTB	WOMENS PARK SPRINKLER PUMP	
112683	7838 MARSH RD	07/20/2023		N		253.08
06/27/2023	COTTRELLVILLE TWP MI, 48039	/ /	0.0000	N		0.00
		07/27/2023		Y		253.08

Open

GL NUMBER	DESCRIPTION	AMOUNT
101-756.000-934.000	OTHER REPAIRS AND MAINTENANCE	253.08

VENDOR TOTAL: 253.08

S038	STATE OF MICHIGAN	06/20/2023	551-619934	FTB	FINGERPRINTING	
112694	MI STATE POLICE-CASHIERS OFFICE	07/20/2023		N		43.25
	PO BOX 30266	/ /	0.0000	N		0.00
07/06/2023	LANSING MI, 48909	08/20/2023		N		43.25

Open

*DANIEL GROSCH 7/5/23 PROCESSED 6/19/23 PAID

GL NUMBER	DESCRIPTION	AMOUNT
101-301.000-802.000	FINGERPRINTING	43.25

VENDOR TOTAL: 43.25

T009	THE CLEANING CREW II LLC	06/29/2023	739565	FTB	CLEANING CITY OFFICE JUNE	
112685	929 LIGHTHOUSE DRIVE	07/20/2023		N		200.00
07/03/2023	MARYSVILLE MI, 48040	/ /	0.0000	N		0.00
		07/27/2023		N		200.00

Open

*4 CLEANINGS

GL NUMBER	DESCRIPTION	AMOUNT
101-265.000-802.000	CLEANING CITY OFFICE	200.00

T009	THE CLEANING CREW II LLC	06/29/2023	739566	FTB	CLEANING LIBRARY JUNE	
112684	3865 PINE	07/20/2023		N		440.00
07/03/2023	FORT GRATIOT MI, 48059	/ /	0.0000	Y		0.00
		07/20/2023		N		440.00

OPEN
 ENCUMBRANCES - 07/20/23

Vendor Code	Vendor name	Post Date	Invoice	Bank	Invoice Description	Gross Amount
Ref #	Address	CK Run Date	PO	Hold		Discount
Invoice Date	City/State/Zip	Disc. Date	Disc. %	Sep CK		Net Amount
Invoice Notes		Due Date		1099		

Open
 *JUNE 1,3,6,8,10,13,17,20,22,27,29

GL NUMBER	DESCRIPTION	AMOUNT
101-790.000-802.000	CLEANING LIBRARY JUNE	440.00
VENDOR TOTAL:		640.00

T996	THE STANDARD - DENTAL INSURANCE	07/01/2023	STATEMENT	FTB	MONTHLY DENTAL RETIREE JULY 2023	
112706	PO BOX 650804	07/20/2023		N		1,491.93
07/01/2023	DALLAS TX, 75265-0804	/ /	0.0000	N		0.00
		07/01/2023		N		1,491.93

Open

GL NUMBER	DESCRIPTION	AMOUNT
736-000.000-723.000	MONTHLY DENTAL RETIREE JULY 2023	1,491.93

T996	THE STANDARD - DENTAL INSURANCE	07/01/2023	STATEMENT	FTB	DENTAL ACTIVE JULY 2023	
112707	PO BOX 650804	07/20/2023		N		526.74
07/01/2023	DALLAS TX, 75265-0804	/ /	0.0000	N		0.00
		07/01/2023		N		526.74

Open

GL NUMBER	DESCRIPTION	AMOUNT
101-215.000-718.001	DENTAL ACTIVE JULY 2023	12.79
101-253.000-718.001	DENTAL ACTIVE JULY 2023	12.79
101-301.000-718.001	DENTAL ACTIVE JULY 2023	242.05
101-371.000-718.001	DENTAL ACTIVE JULY 2023	8.53
101-441.000-718.001	DENTAL ACTIVE JULY 2023	119.65
202-450.000-718.001	DENTAL ACTIVE JULY 2023	19.94
203-450.000-718.001	DENTAL ACTIVE JULY 2023	29.91
592-543.000-718.001	DENTAL ACTIVE JULY 2023	31.57
592-547.000-718.001	DENTAL ACTIVE JULY 2023	49.51
526.74		
VENDOR TOTAL:		2,018.67

T120	THEUT PRODUCTS	06/14/2023	1258960	FTB	STRAW MAT	
112681	73408 VAN DYKE	07/20/2023		N		877.90
06/14/2023	ROMEO MI, 48065-3214	/ /	0.0000	N		0.00
		07/25/2023		N		877.90

User: POSEY

EXP CHECK RUN DATES 07/20/2023 - 07/20/2023

DB: Marine City

JOURNALIZED

OPEN

ENCUMBRANCES - 07/20/23

Vendor Code	Vendor name	Post Date	Invoice	Bank	Invoice Description	Gross Amount
Ref #	Address	CK Run Date	PO	Hold		Discount
Invoice Date	City/State/Zip	Disc. Date	Disc. %	Sep CK		Net Amount
Invoice Notes		Due Date		1099		

Open

GL NUMBER	DESCRIPTION	AMOUNT
101-756.000-752.000	STRAW MAT	877.90
VENDOR TOTAL:		877.90

T074	TRI HOSPITAL EMS	07/20/2023	STATEMENT	FTB	TRI HOSPITAL EMERGENCY MEDICAL SERVICES	
112703	309 GRAND RIVER AVENUE	07/20/2023		N		56,882.06
07/01/2023	PORT HURON MI, 48060	/ /	0.0000	N		0.00
		07/31/2023		N		56,882.06

Open

GL NUMBER	DESCRIPTION	AMOUNT
101-000.000-218.000	DUE TO TRI-HOSPITAL EMERGENCY SERVICES	56,882.06
VENDOR TOTAL:		56,882.06

W100	WILLIAM J KARAS	06/30/2023	STATEMENT	FTB	INSPECTIONS JUNE 2023 MECH AND PLUMBING	
112695	4300 IRENE	07/20/2023		N		381.75
06/30/2023	SAINT CLAIR MI, 48079	/ /	0.0000	N		0.00
		07/31/2023		Y		381.75

Open

*127 BRUCE
263 N BELLE RIVER

GL NUMBER	DESCRIPTION	AMOUNT
101-371.000-802.000	INSPECTIONS JUNE 2023 MECHANICAL	213.75
101-371.000-802.000	INSPECTIONS JUNE 2023 PLUMBING	168.00
VENDOR TOTAL:		381.75

VENDOR TOTAL: 381.75

TOTAL - ALL VENDORS: 275,825.48

Memo

To: City Commission and City Manager
From: Treasurer's Office
Date: 7/12/2023
Re: Preliminary Financial Statements - July 2023

Please include the attached Preliminary Financial Statements for July 2023 on the next City Commission Agenda July 20, 2023.

Thank you

Fund 101 GENERAL FUND

GL Number	Description	Balance
*** Assets ***		
101-000.000-001.001	CASH	2,357,667.67
101-000.000-001.009	CASH-PD SPECIAL ACCOUNT	108.46
101-000.000-001.900	CASH-FLAGSHIP FED CREDIT UNION	13.94
101-000.000-004.000	PETTY CASH - CASH DRAWERS	250.00
101-000.000-004.001	PETTY CASH \$100 - CUSTODIAN	100.00
101-000.000-004.301	PETTY CASH-POLICE DEPARTMENT	100.00
101-000.000-018.100	ALLOWANCE FOR DELINQUENT TAXES	(9,946.45)
101-000.000-040.000	ACCOUNT RECEIVABLE	190.00
101-000.000-040.120	A/R-VARIOUS VENDORS	15,057.22
101-000.000-040.121	A/R IRS OVERPAYMENT	2,591.73
101-000.000-045.001	S/A RECEIVABLE-SIDEWALKS	6,601.21
101-000.000-062.001	LEASE RECEIVABLE	2,970.64
101-000.000-062.002	LEASE RECEIVABLE	25,308.15
101-000.000-062.003	LEASE RECEIVABLE	169.93
101-000.000-072.000	DUE FROM COUNTIES	55,078.18
101-000.000-075.000	DUE FROM SCHOOLS	(12,622.75)
101-000.000-078.000	DUE FROM STATE OF MICHIGAN	272,000.00
101-000.000-084.202	DUE FROM MAJOR STREET FUND	3,763.49
101-000.000-084.203	DUE FROM LOCAL STREET FUND	4,248.13
101-000.000-084.265	DUE FROM DRUG FORFEITURE FUND	0.08
101-000.000-084.309	DUE FROM BROWNFIELD	27,391.41
101-000.000-084.592	DUE FROM WATER FUND	10,113.11
101-000.000-084.703	DUE FROM TAX ACCOUNT FUND	113,908.45
101-000.000-084.704	DUE FROM PAYROLL CLEARING FUND	219.73
101-000.000-123.200	PREPAID POSTAGE	8,502.66
101-000.000-189.001	LEASE RECEIVABLE	243,225.83
101-000.000-189.002	LEASE RECEIVABLE	197,621.81
101-000.000-189.003	LEASE RECEIVABLE	5,526.38
Total Assets		3,330,159.01
*** Liabilities ***		
101-000.000-200.000	ACCOUNTS PAYABLE	245,974.82
101-000.000-200.100	ADDITIONAL ACCOUNTS PAYABLE	7,528.61
101-000.000-214.202	DUE TO MAJOR ROAD FUND	6,211.37
101-000.000-214.203	DUE TO LOCAL ROAD FUND	6,581.00
101-000.000-214.703	DUE TO TAX ACCOUNT	3,723.34
101-000.000-214.704	DUE TO PAYROLL CLEARING FUND	4,861.05
101-000.000-214.731	DUE TO M.C. RETIREMENT SYSTEM	410.34
101-000.000-228.630	DUE TO STATE-SEX OFFENDER REG.	166.75
101-000.000-237.000	INSURANCE PREMIUM CO-PAY (PREPMT)	950.00
101-000.000-257.000	ACCRUED WAGES PAYABLE	38,950.55
101-000.000-362.000	DEFERRED REVENUE	292,891.00
Total Liabilities		608,248.83

User: POSEY

Period Ending 07/31/2023

DB: Marine City

PRELIMINARY FINANCIAL STATEMENTS - JULY 2023

Fund 101 GENERAL FUND

GL Number	Description	Balance
*** Fund Balance ***		
101-000.000-339.000	UNEARNED REVENUE	484,812.95
101-000.000-367.001	DEFERRED INFLOW	246,196.47
101-000.000-367.002	DEFERRED INFLOW	222,929.96
101-000.000-367.003	DEFERRED INFLOW	5,696.31
101-000.000-376.003	PARK IMPROVEMENTS REST. FUNDS	30,465.12
101-000.000-376.004	BEACH FUNRAISER DON-REST FUNDS	1,135.39
101-000.000-376.005	BEACH FUNRAISER GRANT REST FUNDS	2,369.90
101-000.000-376.006	OWI-MCPD REST. FUNDS	187.50
101-000.000-376.007	ROAD TAX MILLAGE REST. FUNDS	121,600.31
101-000.000-376.009	CITY OFFICES REST. FUNDS	137.11
101-000.000-376.010	RIVER REC TEEN ZONE REST. FUNDS	500.00
101-000.000-376.025	COMMUNITY ECONOMIC BOARD RESTRICT	6,533.11
101-000.000-376.029	RESTRICTED FUNDS-TMOBILE GRANT	50,000.00
101-000.000-390.000	FUND BALANCE	1,721,986.66
Total Fund Balance		2,894,550.79
Beginning Fund Balance - 22-23		2,921,271.98
Net of Revenues VS Expenditures - 22-23		81,945.90
*22-23 End FB/23-24 Beg FB		2,976,496.69
Net of Revenues VS Expenditures - Current Year		(254,586.51)
Ending Fund Balance		2,721,910.18
Total Liabilities And Fund Balance		3,330,159.01

* Year Not Closed

Fund 102 GUY CENTER

GL Number	Description	Balance
*** Assets ***		
102-000.000-001.001	CASH	218,369.75
Total Assets		218,369.75
Beginning Fund Balance - 22-23		0.00
Net of Revenues VS Expenditures - 22-23		218,369.75
*22-23 End FB/23-24 Beg FB		0.00
Net of Revenues VS Expenditures - Current Year		0.00
Ending Fund Balance		0.00
Total Liabilities And Fund Balance		218,369.75

* Year Not Closed

User: POSEY

Period Ending 07/31/2023

DB: Marine City

PRELIMINARY FINANCIAL STATEMENTS - JULY 2023

Fund 202 MAJOR STREET FUND

GL Number	Description	Balance
*** Assets ***		
202-000.000-001.001	CASH	1,405,619.55
202-000.000-040.120	A/R-VARIOUS VENDORS	893.88
202-000.000-078.000	DUE FROM STATE OF MICHIGAN	88,669.01
202-000.000-084.101	DUE FROM GENERAL FUND	6,211.37
202-000.000-084.601	DUE FROM ACCOUNTS PAYABLE	147.12
Total Assets		1,501,540.93
*** Liabilities ***		
202-000.000-200.000	ACCOUNTS PAYABLE	1,084.92
202-000.000-214.101	DUE TO GENERAL FUND	3,763.49
202-000.000-214.203	DUE TO LOCAL ROAD FUND	290,057.73
202-000.000-214.592	DUE TO WATER/SEWER FUND	208,731.23
202-000.000-214.601	DUE TO ACCOUNTS PAYABLE	2,207.32
202-000.000-257.000	ACCRUED WAGES PAYABLE	2,367.93
Total Liabilities		508,212.62
*** Fund Balance ***		
202-000.000-390.000	FUND BALANCE	829,492.21
Total Fund Balance		829,492.21
Beginning Fund Balance - 22-23		829,492.21
Net of Revenues VS Expenditures - 22-23		166,170.02
*22-23 End FB/23-24 Beg FB		995,662.23
Net of Revenues VS Expenditures - Current Year		(2,333.92)
Ending Fund Balance		993,328.31
Total Liabilities And Fund Balance		1,501,540.93

* Year Not Closed

Fund 203 LOCAL STREET FUND

GL Number	Description	Balance
*** Assets ***		
203-000.000-001.001	CASH	242,660.06
203-000.000-078.000	DUE FROM STATE OF MICHIGAN	33,976.17
203-000.000-084.101	DUE FROM GENERAL FUND	6,581.00
203-000.000-084.202	DUE FROM MAJOR STREET FUND	290,057.73
203-000.000-084.601	DUE FROM ACCOUNTS PAYABLE	106.86
Total Assets		573,381.82
*** Liabilities ***		
203-000.000-200.000	ACCOUNTS PAYABLE	2,253.23
203-000.000-214.101	DUE TO GENERAL FUND	4,248.13
203-000.000-214.592	DUE TO WATER/SEWER FUND	30,000.00
203-000.000-214.601	DUE TO ACCOUNTS PAYABLE	8,587.90
203-000.000-257.000	ACCRUED WAGES PAYABLE	701.18
Total Liabilities		45,790.44
*** Fund Balance ***		
203-000.000-390.000	FUND BALANCE	602,146.03
Total Fund Balance		602,146.03
Beginning Fund Balance - 22-23		602,146.03
Net of Revenues VS Expenditures - 22-23		(68,977.54)
*22-23 End FB/23-24 Beg FB		533,168.49
Net of Revenues VS Expenditures - Current Year		(5,577.11)
Ending Fund Balance		527,591.38
Total Liabilities And Fund Balance		573,381.82

* Year Not Closed

Fund 209 CEMETERY FUND

GL Number	Description	Balance
*** Assets ***		
209-000.000-001.001	CASH	73,064.47
Total Assets		73,064.47
*** Liabilities ***		
209-000.000-200.000	ACCOUNTS PAYABLE	689.57
209-000.000-214.704	DUE TO PAYROLL CLEARING FUND	3.49
209-000.000-257.000	ACCRUED WAGES PAYABLE	1,065.48
Total Liabilities		1,758.54
*** Fund Balance ***		
209-000.000-390.000	FUND BALANCE	88,381.15
Total Fund Balance		88,381.15
Beginning Fund Balance - 22-23		88,381.15
Net of Revenues VS Expenditures - 22-23		(15,382.35)
*22-23 End FB/23-24 Beg FB		72,998.80
Net of Revenues VS Expenditures - Current Year		(1,692.87)
Ending Fund Balance		71,305.93
Total Liabilities And Fund Balance		73,064.47

* Year Not Closed

Fund 265 DRUG LAW ENFORCEMENT FUND

GL Number	Description	Balance
*** Assets ***		
265-000.000-001.001	CASH	8,626.99
265-000.000-001.007	CASH-PD DRUG ENFORCEMENT FUNDS	410.00
265-000.000-001.008	CASH-PD DRUG FORFEITURE UNJUDICAT	(25.92)
265-000.000-072.000	DUE FROM COUNTIES	375.00
Total Assets		9,386.07
*** Liabilities ***		
265-000.000-214.101	DUE TO GENERAL FUND	0.08
Total Liabilities		0.08
*** Fund Balance ***		
265-000.000-390.000	FUND BALANCE	9,010.99
Total Fund Balance		9,010.99
Beginning Fund Balance - 22-23		9,010.99
Net of Revenues VS Expenditures - 22-23		375.00
*22-23 End FB/23-24 Beg FB		9,385.99
Net of Revenues VS Expenditures - Current Year		0.00
Ending Fund Balance		9,385.99
Total Liabilities And Fund Balance		9,386.07

* Year Not Closed

Fund 309 BROWNFIELD REDEVELOPMENT

GL Number	Description	Balance
*** Assets ***		
309-000.000-001.001	CASH	34,814.70
309-000.000-072.000	DUE FROM COUNTIES	44,278.40
Total Assets		79,093.10
*** Liabilities ***		
309-000.000-214.101	DUE TO GENERAL FUND	27,391.41
309-000.000-362.000	DEFERRED REVENUE	44,278.40
Total Liabilities		71,669.81
*** Fund Balance ***		
309-000.000-390.000	FUND BALANCE	34,814.70
Total Fund Balance		34,814.70
Beginning Fund Balance - 22-23		34,814.70
Net of Revenues VS Expenditures - 22-23		(27,391.41)
*22-23 End FB/23-24 Beg FB		7,423.29
Net of Revenues VS Expenditures - Current Year		0.00
Ending Fund Balance		7,423.29
Total Liabilities And Fund Balance		79,093.10

* Year Not Closed

Fund 401 CAPITAL PROJECTS FUND

GL Number	Description	Balance
*** Assets ***		
401-000.000-001.001	CASH	44,878.07
Total Assets		44,878.07
*** Liabilities ***		
Total Liabilities		0.00
*** Fund Balance ***		
401-000.000-384.000	GRANT SINKING COMMITTED FUNDS	32,129.25
401-000.000-390.000	FUND BALANCE	12,733.88
Total Fund Balance		44,863.13
Beginning Fund Balance - 22-23		44,863.13
Net of Revenues VS Expenditures - 22-23		14.94
Fund Balance Adjustments - 22-23		0.00
*22-23 End FB/23-24 Beg FB		44,878.07
Net of Revenues VS Expenditures - Current Year		0.00
Fund Balance Adjustments		0.00
Ending Fund Balance		44,878.07
Total Liabilities And Fund Balance		44,878.07

* Year Not Closed

User: POSEY

Period Ending 07/31/2023

DB: Marine City

PRELIMINARY FINANCIAL STATEMENTS - JULY 2023

Fund 592 WATER/SEWER FUND

GL Number	Description	Balance
*** Assets ***		
592-000.000-001.001	CASH	1,560,441.66
592-000.000-035.000	UNBILLED UTILITY BILLS RECEIVABLE	369,159.51
592-000.000-040.000	ACCOUNTS RECEIVABLE	140,038.08
592-000.000-045.050	S/A RECEIVABLE	357.16
592-000.000-076.000	DUE FROM TOWNSHIPS	74,942.00
592-000.000-084.202	DUE FROM MAJOR STREET FUND	30,000.00
592-000.000-084.203	DUE FROM LOCAL STREET FUND	208,731.23
592-000.000-084.703	DUE FROM TAX ACCOUNT FUND	756.94
592-000.000-084.704	DUE FROM PAYROLL CLEARING FUND	977.71
592-000.000-131.000	LAND IMPROVEMENTS-NON-DEPR.	63,173.65
592-000.000-152.000	CAPITAL OUTLAY-WATER	7,753,714.89
592-000.000-153.000	WATER SYSTEM/ACCUM DEP-FILTR.	(4,228,116.66)
592-000.000-154.000	CAPITAL OUTLAY -WASTEWATER	15,569,016.96
592-000.000-155.000	ACCUM DEPR SEWER TREATMENT	(14,075,171.70)
592-000.000-196.001	DEFERRED OUTFLOW-PENSION INVEST	268,136.00
592-000.000-197.001	DEFERRED OUTFLOW-CHG IN INVEST EX	18,774.00
Total Assets		7,754,931.43
*** Liabilities ***		
592-000.000-200.000	ACCOUNTS PAYABLE	18,246.75
592-000.000-200.100	ADDITIONAL ACCOUNTS PAYABLE	67,023.48
592-000.000-214.101	DUE TO GENERAL FUND	10,113.11
592-000.000-214.704	DUE TO PAYROLL CLEARING FUND	103.43
592-000.000-251.000	ACCRUED INTEREST PAYABLE	3,099.00
592-000.000-257.000	ACCRUED WAGES PAYABLE	7,401.06
592-000.000-300.000	BONDS PAYABLE	445,000.00
592-000.000-304.000	LEASE PURCHASE PAYABLE-EQUIP.	(8.46)
592-000.000-307.001	APPROP FOR BOND REDEMPTION	20,000.00
592-000.000-334.000	NET PENSION LIABILITY	1,222,602.00
592-000.000-335.000	NET OPEB LIABILITY	1,194,869.00
592-000.000-360.001	DEFERRED INFLOW-CHG IN EXPERIENCE	10,763.00
592-000.000-365.000	DEF. INFLOW-CHG IN INVESTMENT	175,714.00
Total Liabilities		3,174,926.37
*** Fund Balance ***		
592-000.000-376.013	REST. FUNDS-WATER MONITORING	149,091.15
592-000.000-376.014	REST FUNDS-READY TO SERVE WATER	273,594.17
592-000.000-376.015	REST FUNDS-READY TO SERVE SEWER	664,270.49
592-000.000-390.000	FUND BALANCE	3,179,892.28
Total Fund Balance		4,266,848.09

Fund 592 WATER/SEWER FUND

GL Number	Description	Balance
	Beginning Fund Balance - 22-23	4,266,848.09
	Net of Revenues VS Expenditures - 22-23	340,305.00
	*22-23 End FB/23-24 Beg FB	4,607,153.09
	Net of Revenues VS Expenditures - Current Year	(27,148.03)
	Ending Fund Balance	4,580,005.06
	Total Liabilities And Fund Balance	7,754,931.43

* Year Not Closed

User: POSEY

Period Ending 07/31/2023

DB: Marine City

PRELIMINARY FINANCIAL STATEMENTS - JULY 2023

Fund 601 ACCOUNTS PAYABLE FUND

GL Number	Description	Balance
*** Assets ***		
601-000.000-001.001	CASH	(172,282.03)
601-000.000-084.202	DUE FROM MAJOR STREET FUND	2,207.32
601-000.000-084.203	DUE FROM LOCAL STREET FUND	8,587.90
601-000.000-084.703	DUE FROM TAX ACCOUNT FUND	117,900.85
601-000.000-084.736	D/F RETIREE HEALTH INS TRUST	45,965.50
Total Assets		2,379.54
*** Liabilities ***		
601-000.000-214.202	DUE TO MAJOR ROAD FUND	147.12
601-000.000-214.203	DUE TO LOCAL ROAD FUND	106.86
601-000.000-214.703	DUE TO TAX ACCOUNT	633.63
601-000.000-214.736	DUE TO RETIREE HEALTH INSURANCE F	1,491.93
Total Liabilities		2,379.54
*** Fund Balance ***		
Total Fund Balance		0.00
Beginning Fund Balance - 22-23		0.00
Net of Revenues VS Expenditures - 22-23		0.00
*22-23 End FB/23-24 Beg FB		0.00
Net of Revenues VS Expenditures - Current Year		0.00
Ending Fund Balance		0.00
Total Liabilities And Fund Balance		2,379.54

* Year Not Closed

Fund 702 CEMETERY TRUST FUND

GL Number	Description	Balance
*** Assets ***		
702-000.000-002.601	POOL-PERPETUAL CARE (FTB)	124,629.74
702-000.000-002.602	POOL-GUY MAUSOLEUM (FTB)	12,607.13
Total Assets		137,236.87
*** Liabilities ***		
Total Liabilities		0.00
*** Fund Balance ***		
702-000.000-376.016	GUY MAUSOLEUM RESTRICTED FUNDS	7,493.37
702-000.000-376.017	PERPETUAL CARE RESTRICTED FUNDS	88,200.51
702-000.000-390.000	FUND BALANCE	41,497.28
Total Fund Balance		137,191.16
Beginning Fund Balance - 22-23		137,191.16
Net of Revenues VS Expenditures - 22-23		45.71
*22-23 End FB/23-24 Beg FB		137,236.87
Net of Revenues VS Expenditures - Current Year		0.00
Ending Fund Balance		137,236.87
Total Liabilities And Fund Balance		137,236.87

* Year Not Closed

Fund 703 TAX ACCOUNT FUND

GL Number	Description	Balance
*** Assets ***		
703-000.000-001.001	CASH	334,024.13
703-000.000-028.000	TAXES RECEIVABLE-DELQ PERS PROP	38,055.08
703-000.000-084.101	DUE FROM GENERAL FUND	405.85
703-000.000-084.601	DUE FROM ACCOUNTS PAYABLE	633.63
Total Assets		373,118.69
*** Liabilities ***		
703-000.000-214.101	DUE TO GENERAL FUND	37.84
703-000.000-214.601	DUE TO ACCOUNTS PAYABLE	117,900.85
703-000.000-221.000	DUE TO CITY-OPERATING	147,005.09
703-000.000-221.001	DUE TO CITY-REFUSE	7,493.06
703-000.000-221.002	DUE TO CITY-WEEDS	(4.49)
703-000.000-221.003	DUE TO CITY-DELINQUENT WATER	3,359.19
703-000.000-221.004	DUE TO CITY-FMHA S/A	182.03
703-000.000-221.005	DUE TO CITY-PENALTY	2,901.57
703-000.000-221.006	DUE TO CITY-DELINQUENT OPERATING	2,259.93
703-000.000-221.008	DUE TO CITY-W/S DEBT DELQ	4,341.52
703-000.000-221.010	DUE TO CITY-SIDEWALK-ZONE 2 S/A	165.00
703-000.000-222.001	DUE TO COUNTY-OPERATING	10,389.93
703-000.000-222.002	DUE TO COUNTY-DRUGS	56.15
703-000.000-222.003	DUE TO COUNTY-VETERANS	1.53
703-000.000-222.004	DUE TO COUNTY-PARKS	7.59
703-000.000-222.005	DUE TO COUNTY-SENIOR CITIZENS	(35.28)
703-000.000-222.006	DUE TO COUNTY-ROADS	3.83
703-000.000-222.008	DUE TO COUNTY-STATE EDUCATION	11,760.14
703-000.000-222.012	DUE TO COUNTY-DELQ OPERATING	746.74
703-000.000-222.013	DUE TO COUNTY-DELINQUENT DRUGS	156.57
703-000.000-222.014	DUE TO COUNTY-DELQ VETERANS	27.89
703-000.000-222.015	DUE TO COUNTY-DELINQUENT PARKS	137.69
703-000.000-222.016	DUE TO COUNTY-DELQ SR CITIZENS	223.44
703-000.000-222.017	DUE TO COUNTY-DELQ COUNTY ROADS	69.78
703-000.000-222.018	DUE TO COUNTY-DELQ STATE EDUC.	842.68
703-000.000-222.019	DUE TO STATE LAND BANK	802.52
703-000.000-222.427	DUE TO - 74 EMS (MILL DIST)	(20,921.54)
703-000.000-223.002	DUE TO LIBRARY	8.05
703-000.000-223.003	DUE TO LIBRARY-DELINQUENT	195.49
703-000.000-225.001	DUE TO SCHOOLS-OPERATING	(1,810.57)
703-000.000-225.002	DUE TO SCHOOLS-DEBT	3,394.46
703-000.000-225.003	DUE TO SCHOOLS-SINKING FUND	10,056.50
703-000.000-225.004	DUE TO SCHOOLS-DELQ OPERATING	842.68
703-000.000-225.005	DUE TO SCHOOLS-DELINQUENT DEBT	389.74
703-000.000-225.006	DUE TO SCHOOLS-DELQ SINKING FUND	55.91
703-000.000-230.001	DUE TO OTHER UNITS-PEN/INT	11,902.45
703-000.000-234.001	DUE TO ISD-INTERMEDIATE SCHOOL	2,403.65
703-000.000-234.002	DUE TO ISD-VOCATIONAL EDUCATION	1,800.12
703-000.000-234.003	DUE TO ISD-DELQ INT SCHOOL	27.01

Fund 703 TAX ACCOUNT FUND

GL Number	Description	Balance
*** Liabilities ***		
703-000.000-234.004	DUE TO IDS-DELQ VOCATIONAL EDUC.	129.37
703-000.000-235.000	DUE TO COMMUNITY COLLEGE	3,678.72
703-000.000-235.001	DUE TO COMMUNITY COLLEGE-DELQ	264.40
703-000.000-236.000	DUE TO SPECIAL EDUCATION	2,474.33
703-000.000-236.001	DUE TO SPECIAL EDUCATION-DELQ	323.63
703-000.000-240.000	DUE TO COUNTY-AMBULANCE	20,918.87
703-000.000-362.101	DEFERRED REVENUE-GENERAL FUND	9,946.45
703-000.000-362.222	DEFERRED REVENUE-COUNTY	11,436.75
703-000.000-362.225	DEFERRED REVENUE-SCHOOLS	4,769.43
Total Liabilities		373,118.69
*** Fund Balance ***		
Total Fund Balance		0.00
Beginning Fund Balance - 22-23		0.00
Net of Revenues VS Expenditures - 22-23		0.00
*22-23 End FB/23-24 Beg FB		0.00
Net of Revenues VS Expenditures - Current Year		0.00
Ending Fund Balance		0.00
Total Liabilities And Fund Balance		373,118.69

* Year Not Closed

Fund 704 PAYROLL CLEARING FUND

GL Number	Description	Balance
*** Assets ***		
704-000.000-001.001	CASH	6,547.50
704-000.000-084.101	DUE FROM GENERAL FUND	4,863.55
704-000.000-084.209	DUE FROM CEMETERY FUND	3.49
704-000.000-084.592	DUE FROM WATER FUND	103.43
Total Assets		11,517.97
*** Liabilities ***		
704-000.000-214.101	DUE TO GENERAL FUND	3,447.94
704-000.000-214.592	DUE TO WATER/SEWER FUND	977.71
704-000.000-228.000	DUE TO STATE WITHHOLDING	4,021.46
704-000.000-229.001	DUE TO FEDERAL-FED INCOME TAX	(275.74)
704-000.000-231.010	DUE TO HSA-DPW (EMPLOYEE)	1,327.10
704-000.000-239.000	DUE TO HSA-EMPLOYER	2,019.50
Total Liabilities		11,517.97
Beginning Fund Balance - 22-23		0.00
Net of Revenues VS Expenditures - 22-23		0.00
*22-23 End FB/23-24 Beg FB		0.00
Net of Revenues VS Expenditures - Current Year		0.00
Ending Fund Balance		0.00
Total Liabilities And Fund Balance		11,517.97

* Year Not Closed

Fund 731 MARINE CITY RETIREMENT SYSTEM

GL Number	Description	Balance
*** Assets ***		
731-000.000-001.001	CASH	(287,484.12)
731-000.000-017.000	INVESTMENT IN SECURITIES	4,794,896.32
731-000.000-084.101	DUE FROM GENERAL FUND	410.34
Total Assets		4,507,822.54
*** Liabilities ***		
731-000.000-200.000	ACCOUNTS PAYABLE	640.00
Total Liabilities		640.00
*** Fund Balance ***		
731-000.000-390.000	FUND BALANCE	5,070,159.97
Total Fund Balance		5,070,159.97
Beginning Fund Balance - 22-23		5,070,159.97
Net of Revenues VS Expenditures - 22-23		(515,206.11)
*22-23 End FB/23-24 Beg FB		4,554,953.86
Net of Revenues VS Expenditures - Current Year		(47,771.32)
Ending Fund Balance		4,507,182.54
Total Liabilities And Fund Balance		4,507,822.54

* Year Not Closed

Fund 736 RETIREE HEALTH INS TRUST FUND

GL Number	Description	Balance
*** Assets ***		
736-000.000-001.001	CASH	(3,162.57)
736-000.000-017.000	INVESTMENT IN SECURITIES	245,262.68
736-000.000-084.601	DUE FROM ACCOUNTS PAYABLE	1,491.93
Total Assets		243,592.04
*** Liabilities ***		
736-000.000-200.000	ACCOUNTS PAYABLE	1,491.93
736-000.000-214.601	DUE TO ACCOUNTS PAYABLE	45,965.50
Total Liabilities		47,457.43
*** Fund Balance ***		
736-000.000-390.000	FUND BALANCE	295,159.32
Total Fund Balance		295,159.32
Beginning Fund Balance - 22-23		295,159.32
Net of Revenues VS Expenditures - 22-23		(81,379.11)
*22-23 End FB/23-24 Beg FB		213,780.21
Net of Revenues VS Expenditures - Current Year		(17,645.60)
Ending Fund Balance		196,134.61
Total Liabilities And Fund Balance		243,592.04

* Year Not Closed

User: POSEY

DB: Marine City

PERIOD ENDING 07/31/2023

PRELIMINARY FINANCIAL STATEMENTS - JULY 2023

GL NUMBER	2023-24 ORIGINAL BUDGET	2023-24 AMENDED BUDGET	YTD BALANCE 07/31/2023 NORM (ABNORM)	ACTIVITY FOR MONTH 07/31/23 INCR (DECR)	ENCUMBERED YEAR-TO-DATE	UNENCUMBERED BALANCE	% BDGT USED
Fund 101 - GENERAL FUND							
Revenues							
Dept 000.000							
101-000.000-371.000	5,000.00	5,000.00	0.00	0.00	0.00	5,000.00	0.00
101-000.000-402.000	1,800,000.00	1,800,000.00	0.00	0.00	0.00	1,800,000.00	0.00
101-000.000-402.100	27,000.00	27,000.00	0.00	0.00	0.00	27,000.00	0.00
101-000.000-402.300	87,500.00	87,500.00	0.00	0.00	0.00	87,500.00	0.00
101-000.000-412.000	500.00	500.00	0.00	0.00	0.00	500.00	0.00
101-000.000-432.000	7,750.00	7,750.00	0.00	0.00	0.00	7,750.00	0.00
101-000.000-433.000	7,250.00	7,250.00	0.00	0.00	0.00	7,250.00	0.00
101-000.000-445.000	23,000.00	23,000.00	0.00	0.00	0.00	23,000.00	0.00
101-000.000-476.000	13,500.00	13,500.00	617.04	617.04	0.00	12,882.96	4.57
101-000.000-477.001	58,000.00	58,000.00	0.00	0.00	0.00	58,000.00	0.00
101-000.000-490.000	83,000.00	83,000.00	375.00	375.00	0.00	82,625.00	0.45
101-000.000-508.000	500.00	500.00	0.00	0.00	0.00	500.00	0.00
101-000.000-525.000	160,000.00	160,000.00	0.00	0.00	0.00	160,000.00	0.00
101-000.000-543.000	600.00	600.00	0.00	0.00	0.00	600.00	0.00
101-000.000-567.002	5,000.00	5,000.00	0.00	0.00	0.00	5,000.00	0.00
101-000.000-567.011	35,000.00	35,000.00	0.00	0.00	0.00	35,000.00	0.00
101-000.000-574.000	570,000.00	570,000.00	0.00	0.00	0.00	570,000.00	0.00
101-000.000-577.000	6,500.00	6,500.00	0.00	0.00	0.00	6,500.00	0.00
101-000.000-583.000	50,000.00	50,000.00	0.00	0.00	0.00	50,000.00	0.00
101-000.000-614.000	300.00	300.00	0.00	0.00	0.00	300.00	0.00
101-000.000-629.000	21,000.00	21,000.00	0.00	0.00	0.00	21,000.00	0.00
101-000.000-633.000	500.00	500.00	0.00	0.00	0.00	500.00	0.00
101-000.000-634.000	4,000.00	4,000.00	150.00	150.00	0.00	3,850.00	3.75
101-000.000-635.000	500.00	500.00	0.00	0.00	0.00	500.00	0.00
101-000.000-640.000	320,000.00	320,000.00	0.00	0.00	0.00	320,000.00	0.00
101-000.000-650.000	5,000.00	5,000.00	291.31	291.31	0.00	4,708.69	5.83
101-000.000-650.300	14,000.00	14,000.00	0.00	0.00	0.00	14,000.00	0.00
101-000.000-650.301	100.00	100.00	0.00	0.00	0.00	100.00	0.00
101-000.000-650.400	750.00	750.00	101.00	101.00	0.00	649.00	13.47
101-000.000-650.500	100.00	100.00	0.00	0.00	0.00	100.00	0.00
101-000.000-650.600	550.00	550.00	63.25	63.25	0.00	486.75	11.50
101-000.000-650.900	100.00	100.00	0.00	0.00	0.00	100.00	0.00
101-000.000-653.003-PROPCLEAN0	570.00	570.00	0.00	0.00	0.00	570.00	0.00
101-000.000-655.000	10,000.00	10,000.00	0.00	0.00	0.00	10,000.00	0.00
101-000.000-655.001	2,000.00	2,000.00	175.00	175.00	0.00	1,825.00	8.75
101-000.000-655.002	1,000.00	1,000.00	75.00	75.00	0.00	925.00	7.50
101-000.000-659.000	100.00	100.00	0.00	0.00	0.00	100.00	0.00
101-000.000-665.000	100.00	100.00	0.00	0.00	0.00	100.00	0.00
101-000.000-667.000	2,500.00	2,500.00	0.00	0.00	0.00	2,500.00	0.00
101-000.000-667.001	12,210.00	12,210.00	0.00	0.00	0.00	12,210.00	0.00
101-000.000-667.003	31,320.00	31,320.00	0.00	0.00	0.00	31,320.00	0.00
101-000.000-667.005	3,000.00	3,000.00	100.00	100.00	0.00	2,900.00	3.33
101-000.000-674.001	200.00	200.00	0.00	0.00	0.00	200.00	0.00
101-000.000-674.002	7,000.00	7,000.00	0.00	0.00	0.00	7,000.00	0.00
101-000.000-676.004	16,550.00	16,550.00	875.00	875.00	0.00	15,675.00	5.29
101-000.000-681.000	16,430.00	16,430.00	0.00	0.00	0.00	16,430.00	0.00
101-000.000-693.000	1,000.00	1,000.00	0.00	0.00	0.00	1,000.00	0.00
Total Dept 000.000	3,410,980.00	3,410,980.00	2,822.60	2,822.60	0.00	3,408,157.40	0.08
TOTAL REVENUES	3,410,980.00	3,410,980.00	2,822.60	2,822.60	0.00	3,408,157.40	0.08

User: POSEY
DB: Marine City

PERIOD ENDING 07/31/2023

PRELIMINARY FINANCIAL STATEMENTS - JULY 2023

GL NUMBER	2023-24 ORIGINAL BUDGET	2023-24 AMENDED BUDGET	YTD BALANCE 07/31/2023 NORM (ABNORM)	ACTIVITY FOR MONTH 07/31/23 INCR (DECR)	ENCUMBERED YEAR-TO-DATE	UNENCUMBERED BALANCE	% BDGT USED
Fund 101 - GENERAL FUND							
Expenditures							
Dept 101.000 - CITY COMMISSION							
101-101.000-704.004	6,000.00	6,000.00	0.00	0.00	0.00	6,000.00	0.00
101-101.000-709.000	380.00	380.00	0.00	0.00	0.00	380.00	0.00
101-101.000-711.000	90.00	90.00	0.00	0.00	0.00	90.00	0.00
101-101.000-752.000	250.00	250.00	0.00	0.00	0.00	250.00	0.00
101-101.000-861.000	300.00	300.00	0.00	0.00	0.00	300.00	0.00
101-101.000-880.000	250.00	250.00	0.00	0.00	0.00	250.00	0.00
101-101.000-909.000	100.00	100.00	0.00	0.00	0.00	100.00	0.00
101-101.000-911.000	500.00	500.00	0.00	0.00	0.00	500.00	0.00
101-101.000-915.000	7,200.00	7,200.00	2,124.00	2,124.00	0.00	5,076.00	29.50
101-101.000-916.000	500.00	500.00	0.00	0.00	0.00	500.00	0.00
Total Dept 101.000 - CITY COMM	15,570.00	15,570.00	2,124.00	2,124.00	0.00	13,446.00	13.64
Dept 172.000 - CITY MANAGER							
101-172.000-702.000	70,400.00	70,400.00	3,230.76	3,230.76	0.00	67,169.24	4.59
101-172.000-704.001	5,000.00	5,000.00	0.00	0.00	0.00	5,000.00	0.00
101-172.000-709.000	4,675.00	4,675.00	324.31	324.31	0.00	4,350.69	6.94
101-172.000-711.000	1,100.00	1,100.00	75.84	75.84	0.00	1,024.16	6.89
101-172.000-716.001	3,770.00	3,770.00	160.00	160.00	0.00	3,610.00	4.24
101-172.000-718.001	12,000.00	12,000.00	2,000.01	2,000.01	0.00	9,999.99	16.67
101-172.000-723.000	1,200.00	1,200.00	0.00	0.00	0.00	1,200.00	0.00
101-172.000-726.000	120.00	120.00	0.00	0.00	0.00	120.00	0.00
101-172.000-755.000	1,000.00	1,000.00	0.00	0.00	0.00	1,000.00	0.00
101-172.000-791.000	150.00	150.00	0.00	0.00	0.00	150.00	0.00
101-172.000-850.000	2,500.00	2,500.00	537.84	537.84	0.00	1,962.16	21.51
101-172.000-851.001	50.00	50.00	0.00	0.00	0.00	50.00	0.00
101-172.000-861.000	200.00	200.00	0.00	0.00	0.00	200.00	0.00
101-172.000-900.000	100.00	100.00	0.00	0.00	0.00	100.00	0.00
101-172.000-911.000	300.00	300.00	0.00	0.00	0.00	300.00	0.00
101-172.000-915.000	150.00	150.00	0.00	0.00	0.00	150.00	0.00
101-172.000-916.000	600.00	600.00	0.00	0.00	0.00	600.00	0.00
Total Dept 172.000 - CITY MANA	103,315.00	103,315.00	6,328.76	6,328.76	0.00	96,986.24	6.13
Dept 215.000 - CITY CLERK							
101-215.000-702.000	70,000.00	70,000.00	2,698.48	2,698.48	0.00	67,301.52	3.85
101-215.000-709.000	4,640.00	4,640.00	165.92	165.92	0.00	4,474.08	3.58
101-215.000-711.000	1,085.00	1,085.00	38.80	38.80	0.00	1,046.20	3.58
101-215.000-712.000	4,800.00	4,800.00	0.00	0.00	0.00	4,800.00	0.00
101-215.000-716.001	3,500.00	3,500.00	134.92	134.92	0.00	3,365.08	3.85
101-215.000-718.001	1,500.00	1,500.00	122.27	122.27	0.00	1,377.73	8.15
101-215.000-723.000	2,800.00	2,800.00	0.00	0.00	0.00	2,800.00	0.00
101-215.000-726.000	240.00	240.00	3.96	3.96	0.00	236.04	1.65
101-215.000-755.000	1,500.00	1,500.00	0.00	0.00	0.00	1,500.00	0.00
101-215.000-802.000	13,000.00	13,000.00	0.00	0.00	0.00	13,000.00	0.00
101-215.000-824.000	50.00	50.00	0.00	0.00	0.00	50.00	0.00
101-215.000-850.000	2,100.00	2,100.00	37.84	37.84	0.00	2,062.16	1.80
101-215.000-851.001	1,000.00	1,000.00	0.00	0.00	0.00	1,000.00	0.00
101-215.000-861.000	400.00	400.00	0.00	0.00	0.00	400.00	0.00
101-215.000-900.000	200.00	200.00	0.00	0.00	0.00	200.00	0.00
101-215.000-902.000	800.00	800.00	0.00	0.00	0.00	800.00	0.00
101-215.000-909.000	200.00	200.00	0.00	0.00	0.00	200.00	0.00

User: POSEY
DB: Marine City

PERIOD ENDING 07/31/2023

PRELIMINARY FINANCIAL STATEMENTS - JULY 2023

GL NUMBER	2023-24 ORIGINAL BUDGET	2023-24 AMENDED BUDGET	YTD BALANCE 07/31/2023 NORM (ABNORM)	ACTIVITY FOR MONTH 07/31/23 INCR (DECR)	ENCUMBERED YEAR-TO-DATE	UNENCUMBERED BALANCE	% BDGT USED
Fund 101 - GENERAL FUND							
Expenditures							
101-215.000-911.000	800.00	800.00	0.00	0.00	0.00	800.00	0.00
101-215.000-915.000	200.00	200.00	0.00	0.00	0.00	200.00	0.00
101-215.000-916.000	700.00	700.00	0.00	0.00	0.00	700.00	0.00
Total Dept 215.000 - CITY CLER	109,515.00	109,515.00	3,202.19	3,202.19	0.00	106,312.81	2.92
Dept 223.000 - EXTERNAL AUDIT							
101-223.000-801.000	50,000.00	50,000.00	0.00	0.00	0.00	50,000.00	0.00
Total Dept 223.000 - EXTERNAL	50,000.00	50,000.00	0.00	0.00	0.00	50,000.00	0.00
Dept 224.000 - ACTUARIAL SERVICES							
101-224.000-801.000	6,000.00	6,000.00	0.00	0.00	0.00	6,000.00	0.00
Total Dept 224.000 - ACTUARIAL	6,000.00	6,000.00	0.00	0.00	0.00	6,000.00	0.00
Dept 253.000 - TREASURER/FINANCE DEPARTMENT							
101-253.000-702.000	65,000.00	65,000.00	4,127.36	4,127.36	0.00	60,872.64	6.35
101-253.000-704.001	12,000.00	12,000.00	1,760.00	1,760.00	0.00	10,240.00	14.67
101-253.000-709.000	4,775.00	4,775.00	501.37	501.37	0.00	4,273.63	10.50
101-253.000-711.000	1,120.00	1,120.00	117.25	117.25	0.00	1,002.75	10.47
101-253.000-716.001	3,250.00	3,250.00	141.42	141.42	0.00	3,108.58	4.35
101-253.000-718.001	25,000.00	25,000.00	3,345.01	3,345.01	0.00	21,654.99	13.38
101-253.000-723.000	1,600.00	1,600.00	43.28	43.28	0.00	1,556.72	2.71
101-253.000-726.000	300.00	300.00	20.93	20.93	0.00	279.07	6.98
101-253.000-753.000	1,000.00	1,000.00	0.00	0.00	0.00	1,000.00	0.00
101-253.000-755.000	5,000.00	5,000.00	0.00	0.00	0.00	5,000.00	0.00
101-253.000-805.000	3,000.00	3,000.00	0.00	0.00	0.00	3,000.00	0.00
101-253.000-850.000	2,100.00	2,100.00	537.84	537.84	0.00	1,562.16	25.61
101-253.000-851.001	3,500.00	3,500.00	0.00	0.00	0.00	3,500.00	0.00
101-253.000-861.000	500.00	500.00	0.00	0.00	0.00	500.00	0.00
101-253.000-900.000	1,500.00	1,500.00	0.00	0.00	0.00	1,500.00	0.00
101-253.000-909.000	150.00	150.00	0.00	0.00	0.00	150.00	0.00
101-253.000-911.000	1,000.00	1,000.00	0.00	0.00	0.00	1,000.00	0.00
101-253.000-915.000	300.00	300.00	0.00	0.00	0.00	300.00	0.00
101-253.000-916.000	1,300.00	1,300.00	0.00	0.00	0.00	1,300.00	0.00
101-253.000-933.001	5,700.00	5,700.00	0.00	0.00	0.00	5,700.00	0.00
Total Dept 253.000 - TREASURER	138,095.00	138,095.00	10,594.46	10,594.46	0.00	127,500.54	7.67
Dept 257.000 - ASSESSOR/EQUALIZATION DEPARTMENT							
101-257.000-755.000	500.00	500.00	0.00	0.00	0.00	500.00	0.00
101-257.000-802.000	41,000.00	41,000.00	0.00	0.00	0.00	41,000.00	0.00
101-257.000-804.001	700.00	700.00	0.00	0.00	0.00	700.00	0.00
101-257.000-850.000	1,900.00	1,900.00	37.84	37.84	0.00	1,862.16	1.99
101-257.000-851.001	125.00	125.00	0.00	0.00	0.00	125.00	0.00
101-257.000-900.000	250.00	250.00	0.00	0.00	0.00	250.00	0.00
101-257.000-902.000	450.00	450.00	0.00	0.00	0.00	450.00	0.00
101-257.000-933.001	5,700.00	5,700.00	0.00	0.00	0.00	5,700.00	0.00

User: POSEY
DB: Marine City

PERIOD ENDING 07/31/2023

PRELIMINARY FINANCIAL STATEMENTS - JULY 2023

GL NUMBER	2023-24 ORIGINAL BUDGET	2023-24 AMENDED BUDGET	YTD BALANCE 07/31/2023 NORM (ABNORM)	ACTIVITY FOR MONTH 07/31/23 INCR (DECR)	ENCUMBERED YEAR-TO-DATE	UNENCUMBERED BALANCE	% BGDY USED
Fund 101 - GENERAL FUND							
Expenditures							
Total Dept 257.000 - ASSESSOR/	50,625.00	50,625.00	37.84	37.84	0.00	50,587.16	0.07
Dept 262.000 - ELECTIONS							
101-262.000-702.000	3,000.00	3,000.00	0.00	0.00	0.00	3,000.00	0.00
101-262.000-709.000	190.00	190.00	0.00	0.00	0.00	190.00	0.00
101-262.000-711.000	45.00	45.00	0.00	0.00	0.00	45.00	0.00
101-262.000-716.001	150.00	150.00	0.00	0.00	0.00	150.00	0.00
101-262.000-723.000	60.00	60.00	0.00	0.00	0.00	60.00	0.00
101-262.000-752.000	3,600.00	3,600.00	0.00	0.00	0.00	3,600.00	0.00
101-262.000-802.000	2,500.00	2,500.00	0.00	0.00	0.00	2,500.00	0.00
101-262.000-805.001	3,800.00	3,800.00	0.00	0.00	0.00	3,800.00	0.00
101-262.000-851.001	1,000.00	1,000.00	0.00	0.00	0.00	1,000.00	0.00
101-262.000-861.000	150.00	150.00	0.00	0.00	0.00	150.00	0.00
101-262.000-902.000	300.00	300.00	0.00	0.00	0.00	300.00	0.00
101-262.000-909.000	500.00	500.00	0.00	0.00	0.00	500.00	0.00
101-262.000-931.003	500.00	500.00	0.00	0.00	0.00	500.00	0.00
Total Dept 262.000 - ELECTIONS	15,795.00	15,795.00	0.00	0.00	0.00	15,795.00	0.00
Dept 265.000 - BUILDINGS/GROUNDS							
101-265.000-702.000	16,000.00	16,000.00	190.35	190.35	0.00	15,809.65	1.19
101-265.000-704.001	6,000.00	6,000.00	87.75	87.75	0.00	5,912.25	1.46
101-265.000-709.000	1,365.00	1,365.00	16.80	16.80	0.00	1,348.20	1.23
101-265.000-711.000	320.00	320.00	3.93	3.93	0.00	316.07	1.23
101-265.000-716.001	800.00	800.00	9.52	9.52	0.00	790.48	1.19
101-265.000-723.000	500.00	500.00	4.97	4.97	0.00	495.03	0.99
101-265.000-752.000	750.00	750.00	0.00	0.00	0.00	750.00	0.00
101-265.000-755.000	500.00	500.00	0.00	0.00	0.00	500.00	0.00
101-265.000-756.000	2,000.00	2,000.00	0.00	0.00	0.00	2,000.00	0.00
101-265.000-802.000	36,000.00	36,000.00	0.00	0.00	0.00	36,000.00	0.00
101-265.000-884.000	7,500.00	7,500.00	0.00	0.00	0.00	7,500.00	0.00
101-265.000-915.000	120.00	120.00	0.00	0.00	0.00	120.00	0.00
101-265.000-918.000	4,000.00	4,000.00	0.00	0.00	0.00	4,000.00	0.00
101-265.000-920.000	9,000.00	9,000.00	0.00	0.00	0.00	9,000.00	0.00
101-265.000-921.002	6,000.00	6,000.00	0.00	0.00	0.00	6,000.00	0.00
101-265.000-930.000	50,000.00	50,000.00	0.00	0.00	0.00	50,000.00	0.00
101-265.000-948.000	19,000.00	19,000.00	0.00	0.00	975.00	18,025.00	5.13
101-265.000-975.000	0.00	0.00	0.00	0.00	5,252.00	(5,252.00)	0.00
101-265.000-985.000	0.00	0.00	0.00	0.00	4,434.13	(4,434.13)	0.00
Total Dept 265.000 - BUILDINGS	159,855.00	159,855.00	313.32	313.32	10,661.13	148,880.55	6.87
Dept 266.000 - ATTORNEY/CORPORATION COUNSEL							
101-266.000-801.000	65,000.00	65,000.00	0.00	0.00	0.00	65,000.00	0.00
Total Dept 266.000 - ATTORNEY/	65,000.00	65,000.00	0.00	0.00	0.00	65,000.00	0.00
Dept 270.000 - HUMAN RESOURCES DEPARTMENT							
101-270.000-717.001	275,705.00	275,705.00	22,975.43	22,975.43	0.00	252,729.57	8.33
101-270.000-723.000	135,000.00	135,000.00	0.00	0.00	0.00	135,000.00	0.00
101-270.000-842.000	3,500.00	3,500.00	0.00	0.00	0.00	3,500.00	0.00

User: POSEY
DB: Marine City

PERIOD ENDING 07/31/2023

PRELIMINARY FINANCIAL STATEMENTS - JULY 2023

GL NUMBER	2023-24 ORIGINAL BUDGET	2023-24 AMENDED BUDGET	YTD BALANCE 07/31/2023 NORM (ABNORM)	ACTIVITY FOR MONTH 07/31/23 INCR (DECR)	ENCUMBERED YEAR-TO-DATE	UNENCUMBERED BALANCE	% BDGT USED
Fund 101 - GENERAL FUND							
Expenditures							
101-270.000-935.000	88,000.00	88,000.00	133,570.00	133,570.00	0.00	(45,570.00)	151.78
101-270.000-937.000	6,850.00	6,850.00	0.00	0.00	0.00	6,850.00	0.00
Total Dept 270.000 - HUMAN RES	509,055.00	509,055.00	156,545.43	156,545.43	0.00	352,509.57	30.75
Dept 271.000 - SPECIAL PROJECTS							
101-271.000-752.000	3,000.00	3,000.00	0.00	0.00	0.00	3,000.00	0.00
101-271.000-752.100	2,500.00	2,500.00	0.00	0.00	0.00	2,500.00	0.00
101-271.000-802.000	20,000.00	20,000.00	800.00	800.00	0.00	19,200.00	4.00
101-271.000-925.000	10,000.00	10,000.00	0.00	0.00	0.00	10,000.00	0.00
101-271.000-962.000	125.00	125.00	0.00	0.00	0.00	125.00	0.00
101-271.000-995.001	199,110.00	199,110.00	0.00	0.00	0.00	199,110.00	0.00
Total Dept 271.000 - SPECIAL P	234,735.00	234,735.00	800.00	800.00	0.00	233,935.00	0.34
Dept 301.000 - POLICE							
101-301.000-702.000	520,000.00	520,000.00	19,860.80	19,860.80	0.00	500,139.20	3.82
101-301.000-704.001	15,000.00	15,000.00	1,896.51	1,896.51	0.00	13,103.49	12.64
101-301.000-709.000	36,695.00	36,695.00	3,133.65	3,133.65	0.00	33,561.35	8.54
101-301.000-711.000	8,585.00	8,585.00	732.84	732.84	0.00	7,852.16	8.54
101-301.000-712.000	24,000.00	24,000.00	24,000.00	24,000.00	0.00	0.00	100.00
101-301.000-713.000	30,000.00	30,000.00	913.94	913.94	0.00	29,086.06	3.05
101-301.000-714.001	1,050.00	1,050.00	1,500.00	1,500.00	0.00	(450.00)	142.86
101-301.000-716.001	20,000.00	20,000.00	675.19	675.19	0.00	19,324.81	3.38
101-301.000-718.001	36,500.00	36,500.00	2,071.62	2,071.62	0.00	34,428.38	5.68
101-301.000-721.001	1,800.00	1,800.00	2,650.00	2,650.00	0.00	(850.00)	147.22
101-301.000-723.000	6,700.00	6,700.00	230.80	230.80	0.00	6,469.20	3.44
101-301.000-726.000	1,000.00	1,000.00	79.20	79.20	0.00	920.80	7.92
101-301.000-731.000	400.00	400.00	0.00	0.00	0.00	400.00	0.00
101-301.000-752.000	1,500.00	1,500.00	0.00	0.00	0.00	1,500.00	0.00
101-301.000-755.000	1,500.00	1,500.00	0.00	0.00	0.00	1,500.00	0.00
101-301.000-756.000	500.00	500.00	0.00	0.00	0.00	500.00	0.00
101-301.000-757.000	2,000.00	2,000.00	0.00	0.00	0.00	2,000.00	0.00
101-301.000-759.000	20,000.00	20,000.00	0.00	0.00	0.00	20,000.00	0.00
101-301.000-767.000	5,000.00	5,000.00	0.00	0.00	0.00	5,000.00	0.00
101-301.000-791.000	100.00	100.00	0.00	0.00	0.00	100.00	0.00
101-301.000-802.000	20,500.00	20,500.00	0.00	0.00	0.00	20,500.00	0.00
101-301.000-850.000	10,000.00	10,000.00	0.00	0.00	0.00	10,000.00	0.00
101-301.000-851.001	150.00	150.00	0.00	0.00	0.00	150.00	0.00
101-301.000-861.000	300.00	300.00	0.00	0.00	0.00	300.00	0.00
101-301.000-880.000	200.00	200.00	0.00	0.00	0.00	200.00	0.00
101-301.000-884.000	1,400.00	1,400.00	0.00	0.00	0.00	1,400.00	0.00
101-301.000-907.000	1,500.00	1,500.00	0.00	0.00	0.00	1,500.00	0.00
101-301.000-909.000	300.00	300.00	0.00	0.00	0.00	300.00	0.00
101-301.000-911.000	3,000.00	3,000.00	0.00	0.00	0.00	3,000.00	0.00
101-301.000-915.000	300.00	300.00	0.00	0.00	0.00	300.00	0.00
101-301.000-920.000	4,300.00	4,300.00	420.38	420.38	0.00	3,879.62	9.78
101-301.000-921.002	1,000.00	1,000.00	0.00	0.00	0.00	1,000.00	0.00
101-301.000-930.000	1,000.00	1,000.00	0.00	0.00	0.00	1,000.00	0.00
101-301.000-932.000	5,000.00	5,000.00	0.00	0.00	0.00	5,000.00	0.00
101-301.000-933.001	200.00	200.00	0.00	0.00	0.00	200.00	0.00
101-301.000-955.000	300.00	300.00	0.00	0.00	0.00	300.00	0.00
101-301.000-981.000	0.00	0.00	0.00	0.00	80,277.82	(80,277.82)	0.00

User: POSEY
DB: Marine City

PERIOD ENDING 07/31/2023

PRELIMINARY FINANCIAL STATEMENTS - JULY 2023

GL NUMBER	2023-24 ORIGINAL BUDGET	2023-24 AMENDED BUDGET	YTD BALANCE 07/31/2023 NORM (ABNORM)	ACTIVITY FOR MONTH 07/31/23 INCR (DECR)	ENCUMBERED YEAR-TO-DATE	UNENCUMBERED BALANCE	% BDGT USED
Fund 101 - GENERAL FUND							
Expenditures							
101-301.000-985.000	0.00	0.00	0.00	0.00	765.00	(765.00)	0.00
Total Dept 301.000 - POLICE	781,780.00	781,780.00	58,164.93	58,164.93	81,042.82	642,572.25	17.81
Dept 336.000 - FIRE							
101-336.000-802.000	258,100.00	258,100.00	0.00	0.00	0.00	258,100.00	0.00
Total Dept 336.000 - FIRE	258,100.00	258,100.00	0.00	0.00	0.00	258,100.00	0.00
Dept 371.000 - INSPECTIONS/CODE ENFORCEMENT							
101-371.000-702.000	8,600.00	8,600.00	328.00	328.00	0.00	8,272.00	3.81
101-371.000-704.001	10,500.00	10,500.00	357.00	357.00	0.00	10,143.00	3.40
101-371.000-704.001-PROPCLEANO	200.00	200.00	0.00	0.00	0.00	200.00	0.00
101-371.000-709.000	1,185.00	1,185.00	42.17	42.17	0.00	1,142.83	3.56
101-371.000-709.000-PROPCLEANO	15.00	15.00	0.00	0.00	0.00	15.00	0.00
101-371.000-711.000	280.00	280.00	9.86	9.86	0.00	270.14	3.52
101-371.000-711.000-PROPCLEANO	5.00	5.00	0.00	0.00	0.00	5.00	0.00
101-371.000-716.001	430.00	430.00	16.40	16.40	0.00	413.60	3.81
101-371.000-718.001	0.00	0.00	8.53	8.53	0.00	(8.53)	100.00
101-371.000-723.000	300.00	300.00	0.00	0.00	0.00	300.00	0.00
101-371.000-755.000	250.00	250.00	0.00	0.00	0.00	250.00	0.00
101-371.000-802.000	55,000.00	55,000.00	0.00	0.00	0.00	55,000.00	0.00
101-371.000-850.000	2,500.00	2,500.00	37.84	37.84	0.00	2,462.16	1.51
101-371.000-851.001	250.00	250.00	0.00	0.00	0.00	250.00	0.00
101-371.000-900.000	100.00	100.00	0.00	0.00	0.00	100.00	0.00
101-371.000-933.001	1,600.00	1,600.00	0.00	0.00	0.00	1,600.00	0.00
Total Dept 371.000 - INSPECTIO	81,215.00	81,215.00	799.80	799.80	0.00	80,415.20	0.98
Dept 441.000 - GENERAL MAINTENANCE							
101-441.000-702.000	111,000.00	111,000.00	6,010.76	6,010.76	0.00	104,989.24	5.42
101-441.000-704.001	20,000.00	20,000.00	654.63	654.63	0.00	19,345.37	3.27
101-441.000-709.000	8,500.00	8,500.00	667.28	667.28	0.00	7,832.72	7.85
101-441.000-711.000	2,000.00	2,000.00	156.06	156.06	0.00	1,843.94	7.80
101-441.000-712.000	6,000.00	6,000.00	4,200.01	4,200.01	0.00	1,799.99	70.00
101-441.000-716.001	5,850.00	5,850.00	224.90	224.90	0.00	5,625.10	3.84
101-441.000-718.001	27,800.00	27,800.00	1,120.22	1,120.22	0.00	26,679.78	4.03
101-441.000-722.001	200.00	200.00	0.00	0.00	0.00	200.00	0.00
101-441.000-723.000	1,600.00	1,600.00	81.13	81.13	0.00	1,518.87	5.07
101-441.000-726.000	450.00	450.00	34.20	34.20	0.00	415.80	7.60
101-441.000-731.000	500.00	500.00	0.00	0.00	0.00	500.00	0.00
101-441.000-752.000	1,200.00	1,200.00	0.00	0.00	0.00	1,200.00	0.00
101-441.000-755.000	1,000.00	1,000.00	0.00	0.00	0.00	1,000.00	0.00
101-441.000-758.000	9,000.00	9,000.00	0.00	0.00	0.00	9,000.00	0.00
101-441.000-759.000	14,000.00	14,000.00	0.00	0.00	0.00	14,000.00	0.00
101-441.000-767.000	4,000.00	4,000.00	0.00	0.00	7,037.20	(3,037.20)	175.93
101-441.000-802.000	2,700.00	2,700.00	0.00	0.00	0.00	2,700.00	0.00
101-441.000-826.000	700.00	700.00	0.00	0.00	0.00	700.00	0.00
101-441.000-850.000	6,700.00	6,700.00	722.66	722.66	0.00	5,977.34	10.79
101-441.000-851.001	250.00	250.00	0.00	0.00	0.00	250.00	0.00
101-441.000-861.000	100.00	100.00	0.00	0.00	0.00	100.00	0.00
101-441.000-901.000	50.00	50.00	0.00	0.00	0.00	50.00	0.00

User: POSEY
DB: Marine City

PERIOD ENDING 07/31/2023

PRELIMINARY FINANCIAL STATEMENTS - JULY 2023

GL NUMBER	2023-24 ORIGINAL BUDGET	2023-24 AMENDED BUDGET	YTD BALANCE 07/31/2023 NORM (ABNORM)	ACTIVITY FOR MONTH 07/31/23 INCR (DECR)	ENCUMBERED YEAR-TO-DATE	UNENCUMBERED BALANCE	% BDGT USED
Fund 101 - GENERAL FUND							
Expenditures							
101-441.000-909.000	200.00	200.00	0.00	0.00	0.00	200.00	0.00
101-441.000-911.000	1,000.00	1,000.00	0.00	0.00	0.00	1,000.00	0.00
101-441.000-915.000	750.00	750.00	133.75	133.75	0.00	616.25	17.83
101-441.000-920.000	6,500.00	6,500.00	0.00	0.00	0.00	6,500.00	0.00
101-441.000-921.002	6,500.00	6,500.00	0.00	0.00	0.00	6,500.00	0.00
101-441.000-931.003	13,000.00	13,000.00	0.00	0.00	0.00	13,000.00	0.00
101-441.000-932.000	32,000.00	32,000.00	0.00	0.00	0.00	32,000.00	0.00
101-441.000-934.000	2,500.00	2,500.00	0.00	0.00	0.00	2,500.00	0.00
101-441.000-975.000	0.00	0.00	0.00	0.00	3,900.00	(3,900.00)	0.00
101-441.000-995.001	3,700.00	3,700.00	0.00	0.00	0.00	3,700.00	0.00
Total Dept 441.000 - GENERAL M	289,750.00	289,750.00	14,005.60	14,005.60	10,937.20	264,807.20	8.61
Dept 448.000 - STREET LIGHTING							
101-448.000-926.000	93,000.00	93,000.00	0.00	0.00	0.00	93,000.00	0.00
Total Dept 448.000 - STREET LI	93,000.00	93,000.00	0.00	0.00	0.00	93,000.00	0.00
Dept 528.000 - RUBBISH COLLECTION/DISPOSAL							
101-528.000-802.000	330,000.00	330,000.00	0.00	0.00	0.00	330,000.00	0.00
Total Dept 528.000 - RUBBISH C	330,000.00	330,000.00	0.00	0.00	0.00	330,000.00	0.00
Dept 569.000 - WATERSHED COUNCIL							
101-569.000-704.001	1,300.00	1,300.00	52.16	52.16	0.00	1,247.84	4.01
101-569.000-709.000	85.00	85.00	3.23	3.23	0.00	81.77	3.80
101-569.000-711.000	20.00	20.00	0.76	0.76	0.00	19.24	3.80
101-569.000-801.000	1,000.00	1,000.00	0.00	0.00	0.00	1,000.00	0.00
101-569.000-885.000	2,000.00	2,000.00	0.00	0.00	0.00	2,000.00	0.00
101-569.000-911.000	150.00	150.00	0.00	0.00	0.00	150.00	0.00
Total Dept 569.000 - WATERSHED	4,555.00	4,555.00	56.15	56.15	0.00	4,498.85	1.23
Dept 691.000 - SAFETY PROGRAM-EMPLOYEES							
101-691.000-752.000	2,300.00	2,300.00	0.00	0.00	0.00	2,300.00	0.00
101-691.000-931.003	300.00	300.00	0.00	0.00	0.00	300.00	0.00
Total Dept 691.000 - SAFETY PR	2,600.00	2,600.00	0.00	0.00	0.00	2,600.00	0.00
Dept 701.000 - PLANNING							
101-701.000-752.002	2,500.00	2,500.00	0.00	0.00	0.00	2,500.00	0.00
101-701.000-801.000	6,000.00	6,000.00	0.00	0.00	0.00	6,000.00	0.00
101-701.000-902.000	500.00	500.00	0.00	0.00	0.00	500.00	0.00
101-701.000-911.000	100.00	100.00	0.00	0.00	0.00	100.00	0.00
Total Dept 701.000 - PLANNING	9,100.00	9,100.00	0.00	0.00	0.00	9,100.00	0.00
Dept 702.000 - ZONING							

User: POSEY
DB: Marine City

PERIOD ENDING 07/31/2023

PRELIMINARY FINANCIAL STATEMENTS - JULY 2023

GL NUMBER	2023-24 ORIGINAL BUDGET	2023-24 AMENDED BUDGET	YTD BALANCE 07/31/2023 NORM (ABNORM)	ACTIVITY FOR MONTH 07/31/23 INCR (DECR)	ENCUMBERED YEAR-TO-DATE	UNENCUMBERED BALANCE	% BDGT USED
Fund 101 - GENERAL FUND							
Expenditures							
101-702.000-902.000	300.00	300.00	0.00	0.00	0.00	300.00	0.00
101-702.000-911.000	50.00	50.00	0.00	0.00	0.00	50.00	0.00
Total Dept 702.000 - ZONING	350.00	350.00	0.00	0.00	0.00	350.00	0.00
Dept 756.000 - RECREATION/PARK FACILITIES							
101-756.000-702.000	28,000.00	28,000.00	1,448.83	1,448.83	0.00	26,551.17	5.17
101-756.000-704.001	23,000.00	23,000.00	2,211.49	2,211.49	0.00	20,788.51	9.62
101-756.000-709.000	3,165.00	3,165.00	223.95	223.95	0.00	2,941.05	7.08
101-756.000-711.000	740.00	740.00	52.38	52.38	0.00	687.62	7.08
101-756.000-716.001	1,400.00	1,400.00	72.45	72.45	0.00	1,327.55	5.18
101-756.000-723.000	650.00	650.00	38.42	38.42	0.00	611.58	5.91
101-756.000-752.000	5,000.00	5,000.00	0.00	0.00	0.00	5,000.00	0.00
101-756.000-802.000	8,400.00	8,400.00	0.00	0.00	(46.48)	8,446.48	(0.55)
101-756.000-802.001	1,100.00	1,100.00	0.00	0.00	0.00	1,100.00	0.00
101-756.000-850.000	1,150.00	1,150.00	78.16	78.16	0.00	1,071.84	6.80
101-756.000-920.000	2,600.00	2,600.00	0.00	0.00	0.00	2,600.00	0.00
101-756.000-920.001	500.00	500.00	0.00	0.00	0.00	500.00	0.00
101-756.000-930.000	2,000.00	2,000.00	0.00	0.00	12,685.00	(10,685.00)	634.25
101-756.000-931.003	500.00	500.00	0.00	0.00	0.00	500.00	0.00
101-756.000-934.000	1,500.00	1,500.00	0.00	0.00	0.00	1,500.00	0.00
101-756.000-934.001	500.00	500.00	0.00	0.00	0.00	500.00	0.00
101-756.000-974.000	26,000.00	26,000.00	0.00	0.00	5,988.21	20,011.79	23.03
101-756.000-986.000	0.00	0.00	0.00	0.00	666.06	(666.06)	0.00
Total Dept 756.000 - RECREATIO	106,205.00	106,205.00	4,125.68	4,125.68	19,292.79	82,786.53	22.05
Dept 790.000 - LIBRARY							
101-790.000-802.000	7,200.00	7,200.00	0.00	0.00	0.00	7,200.00	0.00
101-790.000-850.000	1,800.00	1,800.00	127.23	127.23	0.00	1,672.77	7.07
101-790.000-920.000	7,900.00	7,900.00	0.00	0.00	0.00	7,900.00	0.00
101-790.000-921.002	1,200.00	1,200.00	0.00	0.00	0.00	1,200.00	0.00
101-790.000-930.000	1,200.00	1,200.00	0.00	0.00	0.00	1,200.00	0.00
Total Dept 790.000 - LIBRARY	19,300.00	19,300.00	127.23	127.23	0.00	19,172.77	0.66
Dept 804.000 - MUSEUM							
101-804.000-702.000	500.00	500.00	0.00	0.00	0.00	500.00	0.00
101-804.000-704.001	600.00	600.00	46.71	46.71	0.00	553.29	7.79
101-804.000-709.000	70.00	70.00	2.90	2.90	0.00	67.10	4.14
101-804.000-711.000	20.00	20.00	0.67	0.67	0.00	19.33	3.35
101-804.000-716.001	25.00	25.00	0.00	0.00	0.00	25.00	0.00
101-804.000-723.000	25.00	25.00	0.00	0.00	0.00	25.00	0.00
101-804.000-752.000	100.00	100.00	0.00	0.00	0.00	100.00	0.00
101-804.000-802.000	600.00	600.00	0.00	0.00	0.00	600.00	0.00
101-804.000-850.000	1,700.00	1,700.00	133.44	133.44	0.00	1,566.56	7.85
101-804.000-920.000	950.00	950.00	0.00	0.00	0.00	950.00	0.00
101-804.000-921.002	1,800.00	1,800.00	0.00	0.00	0.00	1,800.00	0.00
101-804.000-930.000	1,000.00	1,000.00	0.00	0.00	0.00	1,000.00	0.00
Total Dept 804.000 - MUSEUM	7,390.00	7,390.00	183.72	183.72	0.00	7,206.28	2.49

User: POSEY

DB: Marine City

PERIOD ENDING 07/31/2023

PRELIMINARY FINANCIAL STATEMENTS - JULY 2023

GL NUMBER	2023-24 ORIGINAL BUDGET	2023-24 AMENDED BUDGET	YTD BALANCE 07/31/2023 NORM (ABNORM)	ACTIVITY FOR MONTH 07/31/23 INCR (DECR)	ENCUMBERED YEAR-TO-DATE	UNENCUMBERED BALANCE	% BDGT USED
Fund 101 - GENERAL FUND							
Expenditures							
TOTAL EXPENDITURES	3,440,905.00	3,440,905.00	257,409.11	257,409.11	121,933.94	3,061,561.95	11.02
Fund 101 - GENERAL FUND:							
TOTAL REVENUES	3,410,980.00	3,410,980.00	2,822.60	2,822.60	0.00	3,408,157.40	0.08
TOTAL EXPENDITURES	3,440,905.00	3,440,905.00	257,409.11	257,409.11	121,933.94	3,061,561.95	11.02
NET OF REVENUES & EXPENDITURES	(29,925.00)	(29,925.00)	(254,586.51)	(254,586.51)	(121,933.94)	346,595.45	1,258.21

User: POSEY
DB: Marine City

PERIOD ENDING 07/31/2023

PRELIMINARY FINANCIAL STATEMENTS - JULY 2023

GL NUMBER	2023-24 ORIGINAL BUDGET	2023-24 AMENDED BUDGET	YTD BALANCE 07/31/2023 NORM (ABNORM)	ACTIVITY FOR MONTH 07/31/23 INCR (DECR)	ENCUMBERED YEAR-TO-DATE	UNENCUMBERED BALANCE	% BDGT USED
Fund 202 - MAJOR STREET FUND							
Revenues							
Dept 000.000							
202-000.000-546.000	372,000.00	372,000.00	0.00	0.00	0.00	372,000.00	0.00
202-000.000-665.000	900.00	900.00	0.00	0.00	0.00	900.00	0.00
202-000.000-699.000	7,000.00	7,000.00	0.00	0.00	0.00	7,000.00	0.00
Total Dept 000.000	379,900.00	379,900.00	0.00	0.00	0.00	379,900.00	0.00
TOTAL REVENUES	379,900.00	379,900.00	0.00	0.00	0.00	379,900.00	0.00
Expenditures							
Dept 450.000 - GENERAL ADMINISTRATION							
202-450.000-704.001	1,250.00	1,250.00	52.16	52.16	0.00	1,197.84	4.17
202-450.000-709.000	80.00	80.00	46.63	46.63	0.00	33.37	58.29
202-450.000-711.000	20.00	20.00	10.91	10.91	0.00	9.09	54.55
202-450.000-712.000	1,000.00	1,000.00	700.00	700.00	0.00	300.00	70.00
202-450.000-717.001	13,350.00	13,350.00	1,112.49	1,112.49	0.00	12,237.51	8.33
202-450.000-718.001	4,600.00	4,600.00	186.70	186.70	0.00	4,413.30	4.06
202-450.000-723.000	6,750.00	6,750.00	0.00	0.00	0.00	6,750.00	0.00
202-450.000-726.000	90.00	90.00	5.70	5.70	0.00	84.30	6.33
202-450.000-801.000	1,775.00	1,775.00	0.00	0.00	0.00	1,775.00	0.00
202-450.000-940.000	1,500.00	1,500.00	0.00	0.00	0.00	1,500.00	0.00
202-450.000-995.001	186,000.00	186,000.00	0.00	0.00	0.00	186,000.00	0.00
Total Dept 450.000 - GENERAL A	216,415.00	216,415.00	2,114.59	2,114.59	0.00	214,300.41	0.98
Dept 451.000 - DRAINS-STORM SEWERS							
202-451.000-702.000	1,900.00	1,900.00	0.00	0.00	0.00	1,900.00	0.00
202-451.000-704.001	500.00	500.00	0.00	0.00	0.00	500.00	0.00
202-451.000-709.000	150.00	150.00	0.00	0.00	0.00	150.00	0.00
202-451.000-711.000	35.00	35.00	0.00	0.00	0.00	35.00	0.00
202-451.000-716.001	95.00	95.00	0.00	0.00	0.00	95.00	0.00
202-451.000-723.000	40.00	40.00	0.00	0.00	0.00	40.00	0.00
202-451.000-761.000	1,000.00	1,000.00	0.00	0.00	0.00	1,000.00	0.00
202-451.000-934.000	2,000.00	2,000.00	0.00	0.00	0.00	2,000.00	0.00
Total Dept 451.000 - DRAINS-ST	5,720.00	5,720.00	0.00	0.00	0.00	5,720.00	0.00
Dept 452.000 - ROUTINE MAINTENANCE							
202-452.000-702.000	6,700.00	6,700.00	27.54	27.54	0.00	6,672.46	0.41
202-452.000-704.001	1,000.00	1,000.00	0.00	0.00	0.00	1,000.00	0.00
202-452.000-709.000	480.00	480.00	1.66	1.66	0.00	478.34	0.35
202-452.000-711.000	115.00	115.00	0.39	0.39	0.00	114.61	0.34
202-452.000-716.001	335.00	335.00	1.38	1.38	0.00	333.62	0.41
202-452.000-723.000	150.00	150.00	0.71	0.71	0.00	149.29	0.47
202-452.000-752.000	100.00	100.00	0.00	0.00	0.00	100.00	0.00
202-452.000-761.000	3,500.00	3,500.00	0.00	0.00	0.00	3,500.00	0.00
202-452.000-931.003	5,000.00	5,000.00	0.00	0.00	0.00	5,000.00	0.00
202-452.000-934.000	8,000.00	8,000.00	0.00	0.00	0.00	8,000.00	0.00
202-452.000-995.001	18,750.00	18,750.00	0.00	0.00	0.00	18,750.00	0.00

User: POSEY
DB: Marine City

PERIOD ENDING 07/31/2023

PRELIMINARY FINANCIAL STATEMENTS - JULY 2023

GL NUMBER	2023-24 ORIGINAL BUDGET	2023-24 AMENDED BUDGET	YTD BALANCE 07/31/2023 NORM (ABNORM)	ACTIVITY FOR MONTH 07/31/23 INCR (DECR)	ENCUMBERED YEAR-TO-DATE	UNENCUMBERED BALANCE	% BDGT USED
Fund 202 - MAJOR STREET FUND							
Expenditures							
Total Dept 452.000 - ROUTINE M	44,130.00	44,130.00	31.68	31.68	0.00	44,098.32	0.07
Dept 453.000 - BRIDGE MAINTENANCE							
202-453.000-702.000	1,700.00	1,700.00	0.00	0.00	0.00	1,700.00	0.00
202-453.000-704.001	1,200.00	1,200.00	62.28	62.28	0.00	1,137.72	5.19
202-453.000-709.000	180.00	180.00	3.86	3.86	0.00	176.14	2.14
202-453.000-711.000	45.00	45.00	0.90	0.90	0.00	44.10	2.00
202-453.000-716.001	85.00	85.00	0.00	0.00	0.00	85.00	0.00
202-453.000-723.000	75.00	75.00	0.00	0.00	0.00	75.00	0.00
202-453.000-752.000	600.00	600.00	0.00	0.00	0.00	600.00	0.00
202-453.000-802.000	1,000.00	1,000.00	0.00	0.00	0.00	1,000.00	0.00
202-453.000-920.000	800.00	800.00	0.00	0.00	0.00	800.00	0.00
202-453.000-934.000	1,000.00	1,000.00	0.00	0.00	0.00	1,000.00	0.00
Total Dept 453.000 - BRIDGE MA	6,685.00	6,685.00	67.04	67.04	0.00	6,617.96	1.00
Dept 455.000 - ICE AND SNOW CONTROL							
202-455.000-702.000	7,800.00	7,800.00	0.00	0.00	0.00	7,800.00	0.00
202-455.000-704.001	1,000.00	1,000.00	0.00	0.00	0.00	1,000.00	0.00
202-455.000-709.000	550.00	550.00	0.00	0.00	0.00	550.00	0.00
202-455.000-711.000	130.00	130.00	0.00	0.00	0.00	130.00	0.00
202-455.000-716.001	390.00	390.00	0.00	0.00	0.00	390.00	0.00
202-455.000-723.000	150.00	150.00	0.00	0.00	0.00	150.00	0.00
202-455.000-761.000	10,500.00	10,500.00	0.00	0.00	0.00	10,500.00	0.00
202-455.000-931.003	5,000.00	5,000.00	0.00	0.00	0.00	5,000.00	0.00
202-455.000-995.001	18,750.00	18,750.00	0.00	0.00	0.00	18,750.00	0.00
Total Dept 455.000 - ICE AND S	44,270.00	44,270.00	0.00	0.00	0.00	44,270.00	0.00
Dept 456.000 - TRAFFIC SERVICE							
202-456.000-702.000	1,500.00	1,500.00	0.00	0.00	0.00	1,500.00	0.00
202-456.000-704.001	500.00	500.00	0.00	0.00	0.00	500.00	0.00
202-456.000-709.000	125.00	125.00	0.00	0.00	0.00	125.00	0.00
202-456.000-711.000	30.00	30.00	0.00	0.00	0.00	30.00	0.00
202-456.000-716.001	75.00	75.00	0.00	0.00	0.00	75.00	0.00
202-456.000-723.000	30.00	30.00	0.00	0.00	0.00	30.00	0.00
202-456.000-752.000	1,500.00	1,500.00	0.00	0.00	0.00	1,500.00	0.00
202-456.000-802.000	400.00	400.00	0.00	0.00	0.00	400.00	0.00
Total Dept 456.000 - TRAFFIC S	4,160.00	4,160.00	0.00	0.00	0.00	4,160.00	0.00
Dept 464.000 - NON MOTORIZED TRANSPORTATION							
202-464.000-702.000	1,000.00	1,000.00	0.00	0.00	0.00	1,000.00	0.00
202-464.000-704.001	500.00	500.00	0.00	0.00	0.00	500.00	0.00
202-464.000-709.000	95.00	95.00	0.00	0.00	0.00	95.00	0.00
202-464.000-711.000	25.00	25.00	0.00	0.00	0.00	25.00	0.00
202-464.000-716.001	50.00	50.00	0.00	0.00	0.00	50.00	0.00
202-464.000-723.000	20.00	20.00	0.00	0.00	0.00	20.00	0.00
202-464.000-752.000	2,000.00	2,000.00	0.00	0.00	0.00	2,000.00	0.00
202-464.000-974.000	1,500.00	1,500.00	0.00	0.00	0.00	1,500.00	0.00

User: POSEY

DB: Marine City

PERIOD ENDING 07/31/2023

PRELIMINARY FINANCIAL STATEMENTS - JULY 2023

GL NUMBER	2023-24 ORIGINAL BUDGET	2023-24 AMENDED BUDGET	YTD BALANCE 07/31/2023 NORM (ABNORM)	ACTIVITY FOR MONTH 07/31/23 INCR (DECR)	ENCUMBERED YEAR-TO-DATE	UNENCUMBERED BALANCE	% BDGT USED
Fund 202 - MAJOR STREET FUND							
Expenditures							
Total Dept 464.000 - NON MOTOR	5,190.00	5,190.00	0.00	0.00	0.00	5,190.00	0.00
Dept 522.000 - STREET CLEANING							
202-522.000-702.000	2,300.00	2,300.00	104.84	104.84	0.00	2,195.16	4.56
202-522.000-709.000	145.00	145.00	6.20	6.20	0.00	138.80	4.28
202-522.000-711.000	35.00	35.00	1.45	1.45	0.00	33.55	4.14
202-522.000-716.001	115.00	115.00	5.24	5.24	0.00	109.76	4.56
202-522.000-723.000	60.00	60.00	2.88	2.88	0.00	57.12	4.80
202-522.000-752.000	800.00	800.00	0.00	0.00	0.00	800.00	0.00
202-522.000-802.000	1,200.00	1,200.00	0.00	0.00	0.00	1,200.00	0.00
202-522.000-931.003	950.00	950.00	0.00	0.00	0.00	950.00	0.00
Total Dept 522.000 - STREET CL	5,605.00	5,605.00	120.61	120.61	0.00	5,484.39	2.15
TOTAL EXPENDITURES	332,175.00	332,175.00	2,333.92	2,333.92	0.00	329,841.08	0.70
Fund 202 - MAJOR STREET FUND:							
TOTAL REVENUES	379,900.00	379,900.00	0.00	0.00	0.00	379,900.00	0.00
TOTAL EXPENDITURES	332,175.00	332,175.00	2,333.92	2,333.92	0.00	329,841.08	0.70
NET OF REVENUES & EXPENDITURES	47,725.00	47,725.00	(2,333.92)	(2,333.92)	0.00	50,058.92	4.89

User: POSEY
DB: Marine City

PERIOD ENDING 07/31/2023

PRELIMINARY FINANCIAL STATEMENTS - JULY 2023

GL NUMBER	2023-24 ORIGINAL BUDGET	2023-24 AMENDED BUDGET	YTD BALANCE 07/31/2023 NORM (ABNORM)	ACTIVITY FOR MONTH 07/31/23 INCR (DECR)	ENCUMBERED YEAR-TO-DATE	UNENCUMBERED BALANCE	% BGDGT USED
Fund 203 - LOCAL STREET FUND							
Revenues							
Dept 000.000							
203-000.000-546.000	120,000.00	120,000.00	0.00	0.00	0.00	120,000.00	0.00
203-000.000-665.000	600.00	600.00	0.00	0.00	0.00	600.00	0.00
203-000.000-699.000	193,000.00	193,000.00	0.00	0.00	0.00	193,000.00	0.00
Total Dept 000.000	313,600.00	313,600.00	0.00	0.00	0.00	313,600.00	0.00
TOTAL REVENUES	313,600.00	313,600.00	0.00	0.00	0.00	313,600.00	0.00
Expenditures							
Dept 450.000 - GENERAL ADMINISTRATION							
203-450.000-704.001	1,250.00	1,250.00	52.16	52.16	0.00	1,197.84	4.17
203-450.000-709.000	180.00	180.00	68.33	68.33	0.00	111.67	37.96
203-450.000-711.000	40.00	40.00	15.98	15.98	0.00	24.02	39.95
203-450.000-712.000	1,500.00	1,500.00	1,049.99	1,049.99	0.00	450.01	70.00
203-450.000-717.001	26,680.00	26,680.00	2,223.32	2,223.32	0.00	24,456.68	8.33
203-450.000-718.001	6,600.00	6,600.00	280.05	280.05	0.00	6,319.95	4.24
203-450.000-723.000	10,400.00	10,400.00	0.00	0.00	0.00	10,400.00	0.00
203-450.000-726.000	120.00	120.00	8.55	8.55	0.00	111.45	7.13
203-450.000-801.000	1,775.00	1,775.00	0.00	0.00	0.00	1,775.00	0.00
203-450.000-940.000	1,500.00	1,500.00	0.00	0.00	0.00	1,500.00	0.00
Total Dept 450.000 - GENERAL A	50,045.00	50,045.00	3,698.38	3,698.38	0.00	46,346.62	7.39
Dept 451.000 - DRAINS-STORM SEWERS							
203-451.000-702.000	7,000.00	7,000.00	0.00	0.00	0.00	7,000.00	0.00
203-451.000-704.001	1,000.00	1,000.00	0.00	0.00	0.00	1,000.00	0.00
203-451.000-709.000	500.00	500.00	0.00	0.00	0.00	500.00	0.00
203-451.000-711.000	120.00	120.00	0.00	0.00	0.00	120.00	0.00
203-451.000-716.001	350.00	350.00	0.00	0.00	0.00	350.00	0.00
203-451.000-723.000	110.00	110.00	0.00	0.00	0.00	110.00	0.00
203-451.000-752.000	50.00	50.00	0.00	0.00	0.00	50.00	0.00
203-451.000-761.000	3,000.00	3,000.00	0.00	0.00	0.00	3,000.00	0.00
203-451.000-802.000	6,500.00	6,500.00	0.00	0.00	0.00	6,500.00	0.00
203-451.000-934.000	2,500.00	2,500.00	0.00	0.00	0.00	2,500.00	0.00
Total Dept 451.000 - DRAINS-ST	21,130.00	21,130.00	0.00	0.00	0.00	21,130.00	0.00
Dept 452.000 - ROUTINE MAINTENANCE							
203-452.000-702.000	10,500.00	10,500.00	826.13	826.13	0.00	9,673.87	7.87
203-452.000-704.001	3,500.00	3,500.00	62.28	62.28	0.00	3,437.72	1.78
203-452.000-709.000	870.00	870.00	53.58	53.58	0.00	816.42	6.16
203-452.000-711.000	210.00	210.00	12.53	12.53	0.00	197.47	5.97
203-452.000-716.001	525.00	525.00	41.31	41.31	0.00	483.69	7.87
203-452.000-723.000	275.00	275.00	21.61	21.61	0.00	253.39	7.86
203-452.000-752.000	100.00	100.00	0.00	0.00	0.00	100.00	0.00
203-452.000-761.000	2,700.00	2,700.00	0.00	0.00	0.00	2,700.00	0.00
203-452.000-931.003	5,000.00	5,000.00	0.00	0.00	0.00	5,000.00	0.00
203-452.000-934.000	9,000.00	9,000.00	0.00	0.00	1,581.00	7,419.00	17.57
203-452.000-995.001	18,750.00	18,750.00	0.00	0.00	0.00	18,750.00	0.00

User: POSEY
DB: Marine City

PERIOD ENDING 07/31/2023

PRELIMINARY FINANCIAL STATEMENTS - JULY 2023

GL NUMBER	2023-24 ORIGINAL BUDGET	2023-24 AMENDED BUDGET	YTD BALANCE 07/31/2023 NORM (ABNORM)	ACTIVITY FOR MONTH 07/31/23 INCR (DECR)	ENCUMBERED YEAR-TO-DATE	UNENCUMBERED BALANCE	% BGDY USED
Fund 203 - LOCAL STREET FUND							
Expenditures							
Total Dept 452.000 - ROUTINE M	51,430.00	51,430.00	1,017.44	1,017.44	1,581.00	48,831.56	5.05
Dept 455.000 - ICE AND SNOW CONTROL							
203-455.000-702.000	9,200.00	9,200.00	0.00	0.00	0.00	9,200.00	0.00
203-455.000-704.001	1,200.00	1,200.00	0.00	0.00	0.00	1,200.00	0.00
203-455.000-709.000	645.00	645.00	0.00	0.00	0.00	645.00	0.00
203-455.000-711.000	155.00	155.00	0.00	0.00	0.00	155.00	0.00
203-455.000-716.001	460.00	460.00	0.00	0.00	0.00	460.00	0.00
203-455.000-723.000	150.00	150.00	0.00	0.00	0.00	150.00	0.00
203-455.000-761.000	14,000.00	14,000.00	0.00	0.00	0.00	14,000.00	0.00
203-455.000-931.003	5,000.00	5,000.00	0.00	0.00	0.00	5,000.00	0.00
203-455.000-995.001	18,750.00	18,750.00	0.00	0.00	0.00	18,750.00	0.00
Total Dept 455.000 - ICE AND S	49,560.00	49,560.00	0.00	0.00	0.00	49,560.00	0.00
Dept 456.000 - TRAFFIC SERVICE							
203-456.000-702.000	1,800.00	1,800.00	384.24	384.24	0.00	1,415.76	21.35
203-456.000-704.001	600.00	600.00	0.00	0.00	0.00	600.00	0.00
203-456.000-709.000	150.00	150.00	23.10	23.10	0.00	126.90	15.40
203-456.000-711.000	35.00	35.00	5.40	5.40	0.00	29.60	15.43
203-456.000-716.001	90.00	90.00	19.22	19.22	0.00	70.78	21.36
203-456.000-723.000	50.00	50.00	9.91	9.91	0.00	40.09	19.82
203-456.000-752.000	1,950.00	1,950.00	0.00	0.00	0.00	1,950.00	0.00
Total Dept 456.000 - TRAFFIC S	4,675.00	4,675.00	441.87	441.87	0.00	4,233.13	9.45
Dept 464.000 - NON MOTORIZED TRANSPORTATION							
203-464.000-702.000	2,500.00	2,500.00	0.00	0.00	0.00	2,500.00	0.00
203-464.000-704.001	1,300.00	1,300.00	53.46	53.46	0.00	1,246.54	4.11
203-464.000-709.000	240.00	240.00	3.31	3.31	0.00	236.69	1.38
203-464.000-711.000	55.00	55.00	0.77	0.77	0.00	54.23	1.40
203-464.000-716.001	125.00	125.00	0.00	0.00	0.00	125.00	0.00
203-464.000-723.000	50.00	50.00	0.00	0.00	0.00	50.00	0.00
203-464.000-752.000	2,500.00	2,500.00	0.00	0.00	0.00	2,500.00	0.00
203-464.000-974.000	1,300.00	1,300.00	0.00	0.00	0.00	1,300.00	0.00
Total Dept 464.000 - NON MOTOR	8,070.00	8,070.00	57.54	57.54	0.00	8,012.46	0.71
Dept 522.000 - STREET CLEANING							
203-522.000-702.000	7,200.00	7,200.00	314.52	314.52	0.00	6,885.48	4.37
203-522.000-709.000	450.00	450.00	18.62	18.62	0.00	431.38	4.14
203-522.000-711.000	105.00	105.00	4.35	4.35	0.00	100.65	4.14
203-522.000-716.001	360.00	360.00	15.73	15.73	0.00	344.27	4.37
203-522.000-723.000	175.00	175.00	8.66	8.66	0.00	166.34	4.95
203-522.000-752.000	1,200.00	1,200.00	0.00	0.00	0.00	1,200.00	0.00
203-522.000-802.000	1,200.00	1,200.00	0.00	0.00	0.00	1,200.00	0.00
203-522.000-931.003	950.00	950.00	0.00	0.00	0.00	950.00	0.00
Total Dept 522.000 - STREET CL	11,640.00	11,640.00	361.88	361.88	0.00	11,278.12	3.11

User: POSEY
DB: Marine City

PERIOD ENDING 07/31/2023

PRELIMINARY FINANCIAL STATEMENTS - JULY 2023

GL NUMBER	2023-24 ORIGINAL BUDGET	2023-24 AMENDED BUDGET	YTD BALANCE 07/31/2023 NORM (ABNORM)	ACTIVITY FOR MONTH 07/31/23 INCR (DECR)	ENCUMBERED YEAR-TO-DATE	UNENCUMBERED BALANCE	% BDGT USED
Fund 203 - LOCAL STREET FUND							
Expenditures							
TOTAL EXPENDITURES	196,550.00	196,550.00	5,577.11	5,577.11	1,581.00	189,391.89	3.64
Fund 203 - LOCAL STREET FUND:							
TOTAL REVENUES	313,600.00	313,600.00	0.00	0.00	0.00	313,600.00	0.00
TOTAL EXPENDITURES	196,550.00	196,550.00	5,577.11	5,577.11	1,581.00	189,391.89	3.64
NET OF REVENUES & EXPENDITURES	117,050.00	117,050.00	(5,577.11)	(5,577.11)	(1,581.00)	124,208.11	6.12

User: POSEY
DB: Marine City

PERIOD ENDING 07/31/2023

PRELIMINARY FINANCIAL STATEMENTS - JULY 2023

GL NUMBER	2023-24 ORIGINAL BUDGET	2023-24 AMENDED BUDGET	YTD BALANCE 07/31/2023 NORM (ABNORM)	ACTIVITY FOR MONTH 07/31/23 INCR (DECR)	ENCUMBERED YEAR-TO-DATE	UNENCUMBERED BALANCE	% BDGT USED
Fund 209 - CEMETERY FUND							
Revenues							
Dept 000.000							
209-000.000-491.000	8,500.00	8,500.00	0.00	0.00	0.00	8,500.00	0.00
209-000.000-492.000	2,200.00	2,200.00	0.00	0.00	0.00	2,200.00	0.00
209-000.000-680.000	5,000.00	5,000.00	0.00	0.00	0.00	5,000.00	0.00
209-000.000-680.001	650.00	650.00	0.00	0.00	0.00	650.00	0.00
209-000.000-699.000	25,110.00	25,110.00	0.00	0.00	0.00	25,110.00	0.00
Total Dept 000.000	41,460.00	41,460.00	0.00	0.00	0.00	41,460.00	0.00
TOTAL REVENUES	41,460.00	41,460.00	0.00	0.00	0.00	41,460.00	0.00
Expenditures							
Dept 000.000							
209-000.000-702.000	12,000.00	12,000.00	165.02	165.02	0.00	11,834.98	1.38
209-000.000-704.001	6,000.00	6,000.00	706.10	706.10	0.00	5,293.90	11.77
209-000.000-709.000	1,125.00	1,125.00	53.73	53.73	0.00	1,071.27	4.78
209-000.000-711.000	270.00	270.00	12.59	12.59	0.00	257.41	4.66
209-000.000-716.001	600.00	600.00	8.25	8.25	0.00	591.75	1.38
209-000.000-717.001	8,915.00	8,915.00	742.93	742.93	0.00	8,172.07	8.33
209-000.000-723.000	4,600.00	4,600.00	4.25	4.25	0.00	4,595.75	0.09
209-000.000-752.000	2,300.00	2,300.00	0.00	0.00	0.00	2,300.00	0.00
209-000.000-802.000	3,500.00	3,500.00	0.00	0.00	0.00	3,500.00	0.00
209-000.000-805.000	100.00	100.00	0.00	0.00	0.00	100.00	0.00
209-000.000-902.000	50.00	50.00	0.00	0.00	0.00	50.00	0.00
209-000.000-920.000	900.00	900.00	0.00	0.00	0.00	900.00	0.00
209-000.000-933.000	1,000.00	1,000.00	0.00	0.00	0.00	1,000.00	0.00
209-000.000-934.000	100.00	100.00	0.00	0.00	0.00	100.00	0.00
Total Dept 000.000	41,460.00	41,460.00	1,692.87	1,692.87	0.00	39,767.13	4.08
TOTAL EXPENDITURES	41,460.00	41,460.00	1,692.87	1,692.87	0.00	39,767.13	4.08
Fund 209 - CEMETERY FUND:							
TOTAL REVENUES	41,460.00	41,460.00	0.00	0.00	0.00	41,460.00	0.00
TOTAL EXPENDITURES	41,460.00	41,460.00	1,692.87	1,692.87	0.00	39,767.13	4.08
NET OF REVENUES & EXPENDITURES	0.00	0.00	(1,692.87)	(1,692.87)	0.00	1,692.87	100.00

User: POSEY
DB: Marine City

PERIOD ENDING 07/31/2023

PRELIMINARY FINANCIAL STATEMENTS - JULY 2023

GL NUMBER	2023-24 ORIGINAL BUDGET	2023-24 AMENDED BUDGET	YTD BALANCE 07/31/2023 NORM (ABNORM)	ACTIVITY FOR MONTH 07/31/23 INCR (DECR)	ENCUMBERED YEAR-TO-DATE	UNENCUMBERED BALANCE	% BDGT USED
Fund 265 - DRUG LAW ENFORCEMENT FUND							
Revenues							
Dept 000.000							
265-000.000-658.000	500.00	500.00	0.00	0.00	0.00	500.00	0.00
Total Dept 000.000	<u>500.00</u>	<u>500.00</u>	<u>0.00</u>	<u>0.00</u>	<u>0.00</u>	<u>500.00</u>	<u>0.00</u>
TOTAL REVENUES	<u>500.00</u>	<u>500.00</u>	<u>0.00</u>	<u>0.00</u>	<u>0.00</u>	<u>500.00</u>	<u>0.00</u>
Expenditures							
Dept 000.000							
265-000.000-805.000	125.00	125.00	0.00	0.00	0.00	125.00	0.00
265-000.000-958.000	500.00	500.00	0.00	0.00	0.00	500.00	0.00
Total Dept 000.000	<u>625.00</u>	<u>625.00</u>	<u>0.00</u>	<u>0.00</u>	<u>0.00</u>	<u>625.00</u>	<u>0.00</u>
TOTAL EXPENDITURES	<u>625.00</u>	<u>625.00</u>	<u>0.00</u>	<u>0.00</u>	<u>0.00</u>	<u>625.00</u>	<u>0.00</u>
Fund 265 - DRUG LAW ENFORCEMEN							
TOTAL REVENUES	500.00	500.00	0.00	0.00	0.00	500.00	0.00
TOTAL EXPENDITURES	625.00	625.00	0.00	0.00	0.00	625.00	0.00
NET OF REVENUES & EXPENDITURES	(125.00)	(125.00)	0.00	0.00	0.00	(125.00)	0.00

User: POSEY
DB: Marine City

PERIOD ENDING 07/31/2023

PRELIMINARY FINANCIAL STATEMENTS - JULY 2023

GL NUMBER	2023-24 ORIGINAL BUDGET	2023-24 AMENDED BUDGET	YTD BALANCE 07/31/2023 NORM (ABNORM)	ACTIVITY FOR MONTH 07/31/23 INCR (DECR)	ENCUMBERED YEAR-TO-DATE	UNENCUMBERED BALANCE	% BGD USED
Fund 309 - BROWNFIELD REDEVELOPMENT							
Revenues							
Dept 000.000							
309-000.000-596.000	44,600.00	44,600.00	0.00	0.00	0.00	44,600.00	0.00
Total Dept 000.000	44,600.00	44,600.00	0.00	0.00	0.00	44,600.00	0.00
TOTAL REVENUES	44,600.00	44,600.00	0.00	0.00	0.00	44,600.00	0.00
Expenditures							
Dept 000.000							
309-000.000-991.000	24,320.00	24,320.00	0.00	0.00	0.00	24,320.00	0.00
309-000.000-992.000	3,075.00	3,075.00	0.00	0.00	0.00	3,075.00	0.00
Total Dept 000.000	27,395.00	27,395.00	0.00	0.00	0.00	27,395.00	0.00
TOTAL EXPENDITURES	27,395.00	27,395.00	0.00	0.00	0.00	27,395.00	0.00
Fund 309 - BROWNFIELD REDEVLOP							
TOTAL REVENUES	44,600.00	44,600.00	0.00	0.00	0.00	44,600.00	0.00
TOTAL EXPENDITURES	27,395.00	27,395.00	0.00	0.00	0.00	27,395.00	0.00
NET OF REVENUES & EXPENDITURES	17,205.00	17,205.00	0.00	0.00	0.00	17,205.00	0.00

User: POSEY

DB: Marine City

PERIOD ENDING 07/31/2023

PRELIMINARY FINANCIAL STATEMENTS - JULY 2023

GL NUMBER	2023-24 ORIGINAL BUDGET	2023-24 AMENDED BUDGET	YTD BALANCE 07/31/2023 NORM (ABNORM)	ACTIVITY FOR MONTH 07/31/23 INCR (DECR)	ENCUMBERED YEAR-TO-DATE	UNENCUMBERED BALANCE	% BGD USED
Fund 401 - CAPITAL PROJECTS FUND							
Revenues							
Dept 000.000							
401-000.000-699.000	116,200.00	116,200.00	0.00	0.00	0.00	116,200.00	0.00
Total Dept 000.000	<u>116,200.00</u>	<u>116,200.00</u>	<u>0.00</u>	<u>0.00</u>	<u>0.00</u>	<u>116,200.00</u>	<u>0.00</u>
TOTAL REVENUES	<u>116,200.00</u>	<u>116,200.00</u>	<u>0.00</u>	<u>0.00</u>	<u>0.00</u>	<u>116,200.00</u>	<u>0.00</u>
Expenditures							
Dept 000.000							
401-000.000-805.000	50.00	50.00	0.00	0.00	0.00	50.00	0.00
Total Dept 000.000	<u>50.00</u>	<u>50.00</u>	<u>0.00</u>	<u>0.00</u>	<u>0.00</u>	<u>50.00</u>	<u>0.00</u>
TOTAL EXPENDITURES	<u>50.00</u>	<u>50.00</u>	<u>0.00</u>	<u>0.00</u>	<u>0.00</u>	<u>50.00</u>	<u>0.00</u>
Fund 401 - CAPITAL PROJECTS FU							
TOTAL REVENUES	116,200.00	116,200.00	0.00	0.00	0.00	116,200.00	0.00
TOTAL EXPENDITURES	<u>50.00</u>	<u>50.00</u>	<u>0.00</u>	<u>0.00</u>	<u>0.00</u>	<u>50.00</u>	<u>0.00</u>
NET OF REVENUES & EXPENDITURES	116,150.00	116,150.00	0.00	0.00	0.00	116,150.00	0.00

User: POSEY
DB: Marine City

PERIOD ENDING 07/31/2023

PRELIMINARY FINANCIAL STATEMENTS - JULY 2023

GL NUMBER	2023-24 ORIGINAL BUDGET	2023-24 AMENDED BUDGET	YTD BALANCE 07/31/2023 NORM (ABNORM)	ACTIVITY FOR MONTH 07/31/23 INCR (DECR)	ENCUMBERED YEAR-TO-DATE	UNENCUMBERED BALANCE	% BDGT USED
Fund 592 - WATER/SEWER FUND							
Revenues							
Dept 536.000 - WASTEWATER DEPARTMENT REVENUES							
592-536.000-490.002	4,800.00	4,800.00	0.00	0.00	0.00	4,800.00	0.00
592-536.000-636.000	154,800.00	154,800.00	75.06	75.06	0.00	154,724.94	0.05
592-536.000-642.000	533,135.00	533,135.00	31.23	31.23	0.00	533,103.77	0.01
592-536.000-642.100	2,000.00	2,000.00	0.00	0.00	0.00	2,000.00	0.00
592-536.000-643.001	28,300.00	28,300.00	33.24	33.24	0.00	28,266.76	0.12
592-536.000-644.000	140,000.00	140,000.00	0.00	0.00	0.00	140,000.00	0.00
592-536.000-676.004	900.00	900.00	125.00	125.00	0.00	775.00	13.89
592-536.000-699.000	160,000.00	160,000.00	0.00	0.00	0.00	160,000.00	0.00
Total Dept 536.000 - WASTEWATE	1,023,935.00	1,023,935.00	264.53	264.53	0.00	1,023,670.47	0.03
Dept 537.000 - WATER DEPARTMENT REVENUES							
592-537.000-445.000	25.00	25.00	0.00	0.00	0.00	25.00	0.00
592-537.000-490.001	5,800.00	5,800.00	0.00	0.00	0.00	5,800.00	0.00
592-537.000-636.000	104,800.00	104,800.00	50.04	50.04	0.00	104,749.96	0.05
592-537.000-637.000	29,400.00	29,400.00	15.56	15.56	0.00	29,384.44	0.05
592-537.000-642.000	983,990.00	983,990.00	170.20	170.20	0.00	983,819.80	0.02
592-537.000-642.100	2,000.00	2,000.00	0.00	0.00	0.00	2,000.00	0.00
592-537.000-643.000	107,600.00	107,600.00	25.44	25.44	0.00	107,574.56	0.02
592-537.000-645.000	1,000.00	1,000.00	0.00	0.00	0.00	1,000.00	0.00
592-537.000-650.000	600.00	600.00	50.00	50.00	0.00	550.00	8.33
592-537.000-667.004	10,000.00	10,000.00	0.00	0.00	0.00	10,000.00	0.00
592-537.000-676.004	3,000.00	3,000.00	125.00	125.00	0.00	2,875.00	4.17
Total Dept 537.000 - WATER DEP	1,248,215.00	1,248,215.00	436.24	436.24	0.00	1,247,778.76	0.03
TOTAL REVENUES	2,272,150.00	2,272,150.00	700.77	700.77	0.00	2,271,449.23	0.03
Expenditures							
Dept 543.000 - GENERAL ADMINISTRATIVE (SEWER)							
592-543.000-702.000	43,000.00	43,000.00	2,001.33	2,001.33	0.00	40,998.67	4.65
592-543.000-704.001	17,000.00	17,000.00	156.48	156.48	0.00	16,843.52	0.92
592-543.000-709.000	3,740.00	3,740.00	184.18	184.18	0.00	3,555.82	4.92
592-543.000-711.000	880.00	880.00	43.10	43.10	0.00	836.90	4.90
592-543.000-712.000	300.00	300.00	210.00	210.00	0.00	90.00	70.00
592-543.000-716.001	2,165.00	2,165.00	89.06	89.06	0.00	2,075.94	4.11
592-543.000-717.001	48,915.00	48,915.00	4,076.26	4,076.26	0.00	44,838.74	8.33
592-543.000-718.001	6,700.00	6,700.00	1,014.69	1,014.69	0.00	5,685.31	15.14
592-543.000-723.000	13,250.00	13,250.00	7.21	7.21	0.00	13,242.79	0.05
592-543.000-726.000	160.00	160.00	9.82	9.82	0.00	150.18	6.14
592-543.000-755.000	700.00	700.00	0.00	0.00	0.00	700.00	0.00
592-543.000-801.000	10,165.00	10,165.00	0.00	0.00	0.00	10,165.00	0.00
592-543.000-802.000	9,400.00	9,400.00	0.00	0.00	0.00	9,400.00	0.00
592-543.000-827.000	1,150.00	1,150.00	0.00	0.00	0.00	1,150.00	0.00
592-543.000-850.000	900.00	900.00	18.91	18.91	0.00	881.09	2.10
592-543.000-851.001	3,500.00	3,500.00	0.00	0.00	0.00	3,500.00	0.00
592-543.000-900.000	900.00	900.00	0.00	0.00	0.00	900.00	0.00
592-543.000-933.001	2,650.00	2,650.00	0.00	0.00	0.00	2,650.00	0.00
592-543.000-935.000	23,375.00	23,375.00	0.00	0.00	0.00	23,375.00	0.00
592-543.000-937.000	1,100.00	1,100.00	0.00	0.00	0.00	1,100.00	0.00

User: POSEY
DB: Marine City

PERIOD ENDING 07/31/2023

PRELIMINARY FINANCIAL STATEMENTS - JULY 2023

GL NUMBER	2023-24 ORIGINAL BUDGET	2023-24 AMENDED BUDGET	YTD BALANCE 07/31/2023 NORM (ABNORM)	ACTIVITY FOR MONTH 07/31/23 INCR (DECR)	ENCUMBERED YEAR-TO-DATE	UNENCUMBERED BALANCE	% BDGT USED
Fund 592 - WATER/SEWER FUND							
Expenditures							
Total Dept 543.000 - GENERAL A	189,950.00	189,950.00	7,811.04	7,811.04	0.00	182,138.96	4.11
Dept 544.000 - SYSTEM MAINTENANCE (SEWER)							
592-544.000-702.000	13,000.00	13,000.00	0.00	0.00	0.00	13,000.00	0.00
592-544.000-704.001	1,200.00	1,200.00	0.00	0.00	0.00	1,200.00	0.00
592-544.000-709.000	885.00	885.00	0.00	0.00	0.00	885.00	0.00
592-544.000-711.000	210.00	210.00	0.00	0.00	0.00	210.00	0.00
592-544.000-716.001	650.00	650.00	0.00	0.00	0.00	650.00	0.00
592-544.000-723.000	250.00	250.00	0.00	0.00	0.00	250.00	0.00
592-544.000-752.000	500.00	500.00	0.00	0.00	0.00	500.00	0.00
592-544.000-755.000	500.00	500.00	0.00	0.00	0.00	500.00	0.00
592-544.000-761.000	2,300.00	2,300.00	0.00	0.00	0.00	2,300.00	0.00
592-544.000-911.000	900.00	900.00	0.00	0.00	0.00	900.00	0.00
592-544.000-915.000	1,400.00	1,400.00	133.75	133.75	0.00	1,266.25	9.55
592-544.000-931.003	1,000.00	1,000.00	0.00	0.00	0.00	1,000.00	0.00
592-544.000-932.000	5,000.00	5,000.00	0.00	0.00	0.00	5,000.00	0.00
592-544.000-934.000	22,000.00	22,000.00	0.00	0.00	0.00	22,000.00	0.00
592-544.000-992.000	1,250.00	1,250.00	1,241.74	1,241.74	0.00	8.26	99.34
592-544.000-995.001	18,750.00	18,750.00	0.00	0.00	0.00	18,750.00	0.00
Total Dept 544.000 - SYSTEM MA	69,795.00	69,795.00	1,375.49	1,375.49	0.00	68,419.51	1.97
Dept 545.000 - WASTEWATER TREATMENT PLANT							
592-545.000-702.000	30,000.00	30,000.00	1,879.08	1,879.08	0.00	28,120.92	6.26
592-545.000-704.001	4,000.00	4,000.00	133.92	133.92	0.00	3,866.08	3.35
592-545.000-709.000	2,125.00	2,125.00	124.15	124.15	0.00	2,000.85	5.84
592-545.000-711.000	495.00	495.00	29.03	29.03	0.00	465.97	5.86
592-545.000-716.001	1,000.00	1,000.00	56.14	56.14	0.00	943.86	5.61
592-545.000-723.000	30,000.00	30,000.00	9.92	9.92	0.00	29,990.08	0.03
592-545.000-752.000	1,000.00	1,000.00	0.00	0.00	0.00	1,000.00	0.00
592-545.000-753.001	16,000.00	16,000.00	0.00	0.00	0.00	16,000.00	0.00
592-545.000-755.000	500.00	500.00	0.00	0.00	0.00	500.00	0.00
592-545.000-762.000	7,000.00	7,000.00	0.00	0.00	0.00	7,000.00	0.00
592-545.000-802.000	225,000.00	225,000.00	0.00	0.00	0.00	225,000.00	0.00
592-545.000-802.100	75,000.00	75,000.00	0.00	0.00	0.00	75,000.00	0.00
592-545.000-806.000	2,500.00	2,500.00	0.00	0.00	0.00	2,500.00	0.00
592-545.000-822.000	5,500.00	5,500.00	0.00	0.00	0.00	5,500.00	0.00
592-545.000-850.000	2,800.00	2,800.00	206.71	206.71	0.00	2,593.29	7.38
592-545.000-851.001	100.00	100.00	0.00	0.00	0.00	100.00	0.00
592-545.000-915.000	150.00	150.00	133.75	133.75	0.00	16.25	89.17
592-545.000-920.000	80,000.00	80,000.00	0.00	0.00	0.00	80,000.00	0.00
592-545.000-921.002	7,500.00	7,500.00	0.00	0.00	0.00	7,500.00	0.00
592-545.000-930.000	5,000.00	5,000.00	0.00	0.00	0.00	5,000.00	0.00
592-545.000-931.003	30,000.00	30,000.00	0.00	0.00	12,090.74	17,909.26	40.30
592-545.000-934.000	6,000.00	6,000.00	0.00	0.00	0.00	6,000.00	0.00
Total Dept 545.000 - WASTEWATE	531,670.00	531,670.00	2,572.70	2,572.70	12,090.74	517,006.56	2.76
Dept 546.000 - PUMP/LIFT STATION (SEWER)							
592-546.000-702.000	4,500.00	4,500.00	0.00	0.00	0.00	4,500.00	0.00
592-546.000-704.001	1,300.00	1,300.00	0.00	0.00	0.00	1,300.00	0.00
592-546.000-709.000	360.00	360.00	0.00	0.00	0.00	360.00	0.00
592-546.000-711.000	85.00	85.00	0.00	0.00	0.00	85.00	0.00

User: POSEY

DB: Marine City

PERIOD ENDING 07/31/2023

PRELIMINARY FINANCIAL STATEMENTS - JULY 2023

GL NUMBER	2023-24 ORIGINAL BUDGET	2023-24 AMENDED BUDGET	YTD BALANCE 07/31/2023 NORM (ABNORM)	ACTIVITY FOR MONTH 07/31/23 INCR (DECR)	ENCUMBERED YEAR-TO-DATE	UNENCUMBERED BALANCE	% BDGT USED
Fund 592 - WATER/SEWER FUND							
Expenditures							
592-546.000-716.001	225.00	225.00	0.00	0.00	0.00	225.00	0.00
592-546.000-723.000	100.00	100.00	0.00	0.00	0.00	100.00	0.00
592-546.000-752.000	700.00	700.00	0.00	0.00	0.00	700.00	0.00
592-546.000-802.000	2,500.00	2,500.00	0.00	0.00	0.00	2,500.00	0.00
592-546.000-850.000	1,950.00	1,950.00	0.00	0.00	0.00	1,950.00	0.00
592-546.000-920.000	12,500.00	12,500.00	0.00	0.00	0.00	12,500.00	0.00
592-546.000-921.002	2,500.00	2,500.00	0.00	0.00	0.00	2,500.00	0.00
592-546.000-931.003	24,000.00	24,000.00	0.00	0.00	0.00	24,000.00	0.00
592-546.000-934.000	2,500.00	2,500.00	0.00	0.00	0.00	2,500.00	0.00
Total Dept 546.000 - PUMP/LIFT	53,220.00	53,220.00	0.00	0.00	0.00	53,220.00	0.00
Dept 547.000 - GENERAL ADMINISTRATIVE (WATER)							
592-547.000-702.000	43,000.00	43,000.00	2,001.28	2,001.28	0.00	40,998.72	4.65
592-547.000-704.001	17,000.00	17,000.00	156.49	156.49	0.00	16,843.51	0.92
592-547.000-709.000	3,800.00	3,800.00	223.23	223.23	0.00	3,576.77	5.87
592-547.000-711.000	890.00	890.00	52.20	52.20	0.00	837.80	5.87
592-547.000-712.000	1,200.00	1,200.00	840.00	840.00	0.00	360.00	70.00
592-547.000-716.001	2,150.00	2,150.00	89.05	89.05	0.00	2,060.95	4.14
592-547.000-717.001	71,150.00	71,150.00	5,929.16	5,929.16	0.00	65,220.84	8.33
592-547.000-718.001	10,840.00	10,840.00	1,182.70	1,182.70	0.00	9,657.30	10.91
592-547.000-723.000	10,500.00	10,500.00	7.21	7.21	0.00	10,492.79	0.07
592-547.000-726.000	250.00	250.00	14.94	14.94	0.00	235.06	5.98
592-547.000-755.000	700.00	700.00	0.00	0.00	0.00	700.00	0.00
592-547.000-801.000	7,000.00	7,000.00	0.00	0.00	0.00	7,000.00	0.00
592-547.000-827.000	1,150.00	1,150.00	0.00	0.00	0.00	1,150.00	0.00
592-547.000-850.000	900.00	900.00	18.91	18.91	0.00	881.09	2.10
592-547.000-851.001	3,500.00	3,500.00	0.00	0.00	0.00	3,500.00	0.00
592-547.000-900.000	900.00	900.00	0.00	0.00	0.00	900.00	0.00
592-547.000-933.001	2,650.00	2,650.00	0.00	0.00	0.00	2,650.00	0.00
592-547.000-935.000	23,375.00	23,375.00	0.00	0.00	0.00	23,375.00	0.00
592-547.000-937.000	2,950.00	2,950.00	0.00	0.00	0.00	2,950.00	0.00
592-547.000-992.000	9,460.00	9,460.00	0.00	0.00	0.00	9,460.00	0.00
Total Dept 547.000 - GENERAL A	213,365.00	213,365.00	10,515.17	10,515.17	0.00	202,849.83	4.93
Dept 548.000 - SYSTEM MAINTENANCE (WATER)							
592-548.000-702.000	46,500.00	46,500.00	1,787.76	1,787.76	0.00	44,712.24	3.84
592-548.000-704.001	14,000.00	14,000.00	208.63	208.63	0.00	13,791.37	1.49
592-548.000-709.000	3,755.00	3,755.00	119.92	119.92	0.00	3,635.08	3.19
592-548.000-711.000	880.00	880.00	28.04	28.04	0.00	851.96	3.19
592-548.000-716.001	2,325.00	2,325.00	89.38	89.38	0.00	2,235.62	3.84
592-548.000-723.000	1,100.00	1,100.00	46.92	46.92	0.00	1,053.08	4.27
592-548.000-752.000	500.00	500.00	0.00	0.00	0.00	500.00	0.00
592-548.000-755.000	500.00	500.00	0.00	0.00	0.00	500.00	0.00
592-548.000-761.000	4,000.00	4,000.00	0.00	0.00	0.00	4,000.00	0.00
592-548.000-802.000	19,600.00	19,600.00	0.00	0.00	17,489.16	2,110.84	89.23
592-548.000-911.000	1,000.00	1,000.00	0.00	0.00	0.00	1,000.00	0.00
592-548.000-915.000	1,700.00	1,700.00	133.75	133.75	0.00	1,566.25	7.87
592-548.000-931.003	100.00	100.00	0.00	0.00	0.00	100.00	0.00
592-548.000-932.000	5,000.00	5,000.00	0.00	0.00	0.00	5,000.00	0.00
592-548.000-934.000	34,000.00	34,000.00	0.00	0.00	7,248.24	26,751.76	21.32
592-548.000-992.000	1,250.00	1,250.00	1,241.74	1,241.74	0.00	8.26	99.34

User: POSEY

DB: Marine City

PERIOD ENDING 07/31/2023

PRELIMINARY FINANCIAL STATEMENTS - JULY 2023

GL NUMBER	2023-24 ORIGINAL BUDGET	2023-24 AMENDED BUDGET	YTD BALANCE 07/31/2023 NORM (ABNORM)	ACTIVITY FOR MONTH 07/31/23 INCR (DECR)	ENCUMBERED YEAR-TO-DATE	UNENCUMBERED BALANCE	% BDGT USED
Fund 592 - WATER/SEWER FUND							
Expenditures							
592-548.000-995.001	18,750.00	18,750.00	0.00	0.00	0.00	18,750.00	0.00
Total Dept 548.000 - SYSTEM MA	154,960.00	154,960.00	3,656.14	3,656.14	24,737.40	126,566.46	18.32
Dept 549.000 - WATER PLANT							
592-549.000-702.000	28,000.00	28,000.00	1,551.48	1,551.48	0.00	26,448.52	5.54
592-549.000-704.001	850.00	850.00	27.00	27.00	0.00	823.00	3.18
592-549.000-709.000	1,790.00	1,790.00	97.75	97.75	0.00	1,692.25	5.46
592-549.000-711.000	425.00	425.00	22.85	22.85	0.00	402.15	5.38
592-549.000-716.001	1,400.00	1,400.00	39.77	39.77	0.00	1,360.23	2.84
592-549.000-723.000	30,000.00	30,000.00	1.42	1.42	0.00	29,998.58	0.00
592-549.000-752.000	1,000.00	1,000.00	0.00	0.00	0.00	1,000.00	0.00
592-549.000-753.001	32,000.00	32,000.00	0.00	0.00	0.00	32,000.00	0.00
592-549.000-755.000	500.00	500.00	0.00	0.00	0.00	500.00	0.00
592-549.000-756.000	1,000.00	1,000.00	0.00	0.00	0.00	1,000.00	0.00
592-549.000-762.000	12,000.00	12,000.00	0.00	0.00	0.00	12,000.00	0.00
592-549.000-802.000	310,000.00	310,000.00	0.00	0.00	0.00	310,000.00	0.00
592-549.000-802.400	11,000.00	11,000.00	0.00	0.00	0.00	11,000.00	0.00
592-549.000-820.000	1,600.00	1,600.00	0.00	0.00	0.00	1,600.00	0.00
592-549.000-850.000	3,600.00	3,600.00	177.99	177.99	0.00	3,422.01	4.94
592-549.000-851.001	100.00	100.00	0.00	0.00	0.00	100.00	0.00
592-549.000-920.000	36,000.00	36,000.00	0.00	0.00	0.00	36,000.00	0.00
592-549.000-921.002	6,000.00	6,000.00	0.00	0.00	0.00	6,000.00	0.00
592-549.000-930.000	1,500.00	1,500.00	0.00	0.00	0.00	1,500.00	0.00
592-549.000-931.003	35,000.00	35,000.00	0.00	0.00	0.00	35,000.00	0.00
592-549.000-934.000	4,000.00	4,000.00	0.00	0.00	0.00	4,000.00	0.00
Total Dept 549.000 - WATER PLA	517,765.00	517,765.00	1,918.26	1,918.26	0.00	515,846.74	0.37
TOTAL EXPENDITURES	1,730,725.00	1,730,725.00	27,848.80	27,848.80	36,828.14	1,666,048.06	3.74
Fund 592 - WATER/SEWER FUND:							
TOTAL REVENUES	2,272,150.00	2,272,150.00	700.77	700.77	0.00	2,271,449.23	0.03
TOTAL EXPENDITURES	1,730,725.00	1,730,725.00	27,848.80	27,848.80	36,828.14	1,666,048.06	3.74
NET OF REVENUES & EXPENDITURES	541,425.00	541,425.00	(27,148.03)	(27,148.03)	(36,828.14)	605,401.17	11.82

User: POSEY

PERIOD ENDING 07/31/2023

DB: Marine City

PRELIMINARY FINANCIAL STATEMENTS - JULY 2023

GL NUMBER	2023-24 ORIGINAL BUDGET	2023-24 AMENDED BUDGET	YTD BALANCE 07/31/2023 NORM (ABNORM)	ACTIVITY FOR MONTH 07/31/23 INCR (DECR)	ENCUMBERED YEAR-TO-DATE	UNENCUMBERED BALANCE	% BDGT USED
Fund 702 - CEMETERY TRUST FUND							
Expenditures							
Dept 000.000							
702-000.000-805.000	150.00	150.00	0.00	0.00	0.00	150.00	0.00
Total Dept 000.000	<u>150.00</u>	<u>150.00</u>	<u>0.00</u>	<u>0.00</u>	<u>0.00</u>	<u>150.00</u>	<u>0.00</u>
TOTAL EXPENDITURES	<u>150.00</u>	<u>150.00</u>	<u>0.00</u>	<u>0.00</u>	<u>0.00</u>	<u>150.00</u>	<u>0.00</u>
Fund 702 - CEMETERY TRUST FUND							
TOTAL REVENUES	0.00	0.00	0.00	0.00	0.00	0.00	0.00
TOTAL EXPENDITURES	<u>150.00</u>	<u>150.00</u>	<u>0.00</u>	<u>0.00</u>	<u>0.00</u>	<u>150.00</u>	<u>0.00</u>
NET OF REVENUES & EXPENDITURES	(150.00)	(150.00)	0.00	0.00	0.00	(150.00)	0.00

User: POSEY

PERIOD ENDING 07/31/2023

DB: Marine City

PRELIMINARY FINANCIAL STATEMENTS - JULY 2023

GL NUMBER	2023-24 ORIGINAL BUDGET	2023-24 AMENDED BUDGET	YTD BALANCE 07/31/2023 NORM (ABNORM)	ACTIVITY FOR MONTH 07/31/23 INCR (DECR)	ENCUMBERED YEAR-TO-DATE	UNENCUMBERED BALANCE	% BDGT USED
Fund 731 - MARINE CITY RETIREMENT SYSTEM							
Expenditures							
Dept 000.000							
731-000.000-874.000	0.00	0.00	45,925.17	45,925.17	0.00	(45,925.17)	100.00
731-000.000-874.001	0.00	0.00	1,846.15	1,846.15	0.00	(1,846.15)	100.00
Total Dept 000.000	0.00	0.00	47,771.32	47,771.32	0.00	(47,771.32)	100.00
TOTAL EXPENDITURES	0.00	0.00	47,771.32	47,771.32	0.00	(47,771.32)	100.00
Fund 731 - MARINE CITY RETIREM							
TOTAL REVENUES	0.00	0.00	0.00	0.00	0.00	0.00	0.00
TOTAL EXPENDITURES	0.00	0.00	47,771.32	47,771.32	0.00	(47,771.32)	100.00
NET OF REVENUES & EXPENDITURES	0.00	0.00	(47,771.32)	(47,771.32)	0.00	47,771.32	100.00

PERIOD ENDING 07/31/2023

PRELIMINARY FINANCIAL STATEMENTS - JULY 2023

GL NUMBER	2023-24 ORIGINAL BUDGET	2023-24 AMENDED BUDGET	YTD BALANCE 07/31/2023 NORM (ABNORM)	ACTIVITY FOR MONTH 07/31/23 INCR (DECR)	ENCUMBERED YEAR-TO-DATE	UNENCUMBERED BALANCE	% BDGT USED
Fund 736 - RETIREE HEALTH INS TRUST FUND							
Revenues							
Dept 000.000							
736-000.000-684.000	0.00	0.00	(416.66)	(416.66)	0.00	416.66	100.00
Total Dept 000.000	0.00	0.00	(416.66)	(416.66)	0.00	416.66	100.00
TOTAL REVENUES	0.00	0.00	(416.66)	(416.66)	0.00	416.66	100.00
Expenditures							
Dept 000.000							
736-000.000-723.000	0.00	0.00	17,228.94	17,228.94	0.00	(17,228.94)	100.00
Total Dept 000.000	0.00	0.00	17,228.94	17,228.94	0.00	(17,228.94)	100.00
TOTAL EXPENDITURES	0.00	0.00	17,228.94	17,228.94	0.00	(17,228.94)	100.00
Fund 736 - RETIREE HEALTH INS							
TOTAL REVENUES	0.00	0.00	(416.66)	(416.66)	0.00	416.66	100.00
TOTAL EXPENDITURES	0.00	0.00	17,228.94	17,228.94	0.00	(17,228.94)	100.00
NET OF REVENUES & EXPENDITURES	0.00	0.00	(17,645.60)	(17,645.60)	0.00	17,645.60	100.00
TOTAL REVENUES - ALL FUNDS							
TOTAL REVENUES - ALL FUNDS	6,579,390.00	6,579,390.00	3,106.71	3,106.71	0.00	6,576,283.29	0.05
TOTAL EXPENDITURES - ALL FUNDS	5,770,035.00	5,770,035.00	359,862.07	359,862.07	160,343.08	5,249,829.85	9.02
NET OF REVENUES & EXPENDITURES	809,355.00	809,355.00	(356,755.36)	(356,755.36)	(160,343.08)	1,326,453.44	63.89

stated businesses will buy licenses and not build out the business to deter competition from opening but that does not help the community in terms of tax sharing.

Commissioner Klaassen stated business get the license and the State can pull the license if the business is in debt to the City or in violation of any local ordinance.

Mayor Vandebossche stated she was for the need for businesses and promoting but she would vote no if the vote came up. She also stated City Attorney Davis advised at a previous meeting that a ballot initiative could not be advising in nature and needed to be specific and actionable.

Commissioner Ross stated citizens who reached out to him were mostly against marijuana facilities and he did not want the Commission blindsided by a ballot initiative. He also stated the maps did not reveal the spot in Marine City where a facility could go.

Commissioner Hilferink stated the Commission could not forget the Marijuana Town Hall was 50/50 for and against and to not forget the vote in Marine City when Michigan legalized recreational marijuana.

Mayor Vandebossche inquired of Commissioner Klaassen if he did in fact talk to businesses in the old K-Mart Plaza who did not want marijuana facilities. Commissioner Klaassen confirmed he did talk to business owners there who did not want it.

Commissioner Roehrig stated she would like the Commission to create a ballot proposal with language that specifically allows dispensaries but excludes grows. City Manager Adkins stated the Commission would need to vote on language and that there was a review process at the County and State level for all ballot language.

Motion by Commissioner Hilferink, seconded by Commissioner Hendrick to direct the City Attorney to craft actionable ballot language to allow dispensaries, but to not allow grow facilities or production facilities, in the City with setbacks of 1,000 feet from building to building with respect to residential zones and from schools, churches and rehab facilities and establish specified marijuana zoning districts if needed, to be put on the ballot. **Roll Call Vote.** Ayes: Roehrig, Ross, Vandebossche, Hendrick, Hilferink. Nays: Klaassen, Bryson. Motion Carried.

NEW BUSINESS

Michigan Municipal League Worker's Compensation Fund Renewal

Motion by Commissioner Bryson, seconded by Commissioner Klaassen, to approve the Worker's Compensation Insurance renewal with the Michigan Municipal League Worker's Compensation Fund in the amount of \$10,430.00. **Roll Call Vote.** Ayes: Roehrig, Ross, Vandebossche, Bryson, Hendrick, Hilferink, Klaassen. Nays: None. Motion Carried.

Bureau of Fire Services
P.O. Box 30700
Lansing, MI 48909
(517) 241-8847

Authority: 1988 PA 358 Compliance: Voluntary Penalty: Permit will not be issued	The Department of Energy, Labor & Economic Growth will not discriminate against any individual or group because of race, sex, religion, age, national origin, color, material status, disability, or political beliefs. If you need assistance with reading, writing, hearing, etc., under the American with Disabilities Act, you may make your needs known to this agency.
---	--

This permit is not transferable. It authorizes the resident wholesale dealer or jobber named below to have in his or her possession fireworks of any type, for sale only to holders of permits for public display or agriculture control.

PUBLIC DISPLAY

AGRICULTURAL PEST CONTROL

Issued To Pyrotecnico Fireworks, Inc.		Age (18 or over) Yes
Address 4369 E Summit Woods Dr NE, Rockford, MI 49341		
Name of Organization, Group, Firm, or Corporation Maritime Days Festival		
Address 311 Broadway, Marine City MI 48039		
Number and Types of Fireworks Approximately 1000 aerial display shells ranging in size from 1 ¼ inches to 8 inches in diameter.		
Exact Location of Display St. Clair River in front of Marine City MI		
City, Village, Township Marine City, MI	Date August 4, 2023	Time Approximately 10:00 pm
Bond or Insurance Filled? <input checked="" type="checkbox"/> Yes <input type="checkbox"/> No		Amount \$10,000,000.00

Issued by action of: Council Commission Board of the

City Village Township of _____
(Name of City, Village, Township)

on the _____ day of _____,

(Signature and Title of Council/Commission/Board Representative)

Instructions for Application for Fireworks Other Than Consumer or Low Impact

Applications shall be submitted to the legislative body of a city, village or township board. A permit may be issued as a result of official action by the legislative body. A permit shall be valid only for use within the limits of the jurisdiction of the legislative body of a city, village or township board.

1. Type of Permit – check all boxes that may apply to the type of permit needed. You may select several permit types depending on your fireworks display. You may check with your legislative body of a city, village or township board for assistance when making your selection. Please review the following definitions to determine which type of permit to select:
 - Agricultural or Wildlife Fireworks – devices distributed to farmers, ranchers, and growers through a wildlife management program administered by the US Department of Interior or Michigan DNR.
 - Articles Pyrotechnic – 1.4G fireworks for professional use only that is classified as UN0431 or UN0432.
 - Display Fireworks – 1.3G fireworks for professional use only
 - Special Effects Manufactured for Outdoor Pest Control or Agricultural Purposes – devices with a combination of chemical elements or compounds capable of burning independently of the oxygen of the atmosphere and designed and intended to produce an audible, visual, mechanical or thermal effect for pest or animal control.
 - Public Display – a fireworks display that is open to all persons for viewing.
 - Private Display – a fireworks display that is not open to the general public for viewing.
2. Name of applicant – list the name of the applicant. The applicant may be a person representing an organization, group, firm or corporation, or self. If the applicant is also the operator, enter the same name in the operator's section.
3. Address of applicant – complete the address of the applicant; include the street address, city, state and zip code.
4. Name of person or resident agent representing corporation, LLC, DBA or other – list the name of the person or resident agent that represents the corporation, LLC, DBA or other.
5. Address of person or resident agent that represents the corporation, LLC, DBA or other – list the address of the person or resident agent representing the corporation, LLC, DBA or other.
6. Non-resident applicant – list the name of the non-resident applicant. A non-resident applicant shall appoint a Michigan attorney or Michigan resident agent in writing to be the applicant's legal representative upon whom all service of process in any action or proceeding may be served.
7. Name of pyrotechnic operator – list the name of the pyrotechnic operator. The pyrotechnic operator is the person in charge of the display. The legislative body of a city, village or township board shall rule on the competency and qualifications of the operator before granting a permit and may require an affidavit from the applicant as to the operator's experience, former pyrotechnic accidents, criminal record, sobriety, etc.
8. Address of pyrotechnic operator – list the address of the pyrotechnic operator; include the street address, city, state and zip code.
9. Age of the pyrotechnic operator – list the age of the pyrotechnic operator; the operator must be 18 years of age or older.
10. Name of assistant – list the name of the assistant to the pyrotechnic operator;
11. Address of assistant – list the address of the assistant; include the street address, city, state and zip code. If there is more than one assistant, please list additional assistants on a separate sheet and include the address and age of those additional assistants.
12. Age of assistant – list the age of the assistant to the pyrotechnic operator; the assistant must be 18 years or older.
13. Name of other assistant – list the name of other assistant to the pyrotechnic operator.
14. Age of other assistant – list the age of the assistant to the pyrotechnic operator; the assistant must be 18 years or older.
15. Exact location of proposed display – list the address of the exact location of the proposed fireworks display.
16. Date of proposed display – indicate the date of the proposed fireworks display; only one display date can be used per application.
17. Time of proposed display – indicate the time of the proposed fireworks display.
18. Manner and place of storage - indicate the manner and place of storage within the legislative body of a city, village or township board of fireworks that are ready for display, just prior to the display in the area of exhibition. The legislative body of a city, village or township board shall obtain approval from the local fire authorities of the manner and place of storage before any permit is issued.

19. Amount of bond or insurance - the issuing legislative body of a city, village or township board shall set the amount of and proof of bond or insurance for the protection of the public to satisfy claims for damages to property or personal injuries arising out of any act or omission on the part of the person, firm or corporation, or any agent or employee of the applicant. The applicant shall assure the bond or insurance required is provided.
20. Name of bonding corporation or insurance company – provide the name of the bonding corporation or insurance company for which the bond was issued through.
21. Address of bonding corporation or insurance company – list the address of the bonding corporation or insurance company; include the street address, city, state and zip code.
22. Number of fireworks and kind of fireworks to be displayed– indicate the total amount of fireworks proposed for the display or use and a description of the type of fireworks for display; such as 10 aerial bombs, 30 aerial rocket bursts, etc.
23. The application is valid for the calendar year in which the application was received and permit was issued.
24. Permit fees shall be established by the legislative body of a city, village or township board and shall be submitted to and retained by legislative body of a city, village or township board.
25. Permitting will be in compliance with the Michigan Fireworks Safety Act, PA 256 of 2011, MCL 28.466, Section 16.
26. **Mail the application to the legislative body of a city, village or township board within the location jurisdiction of the display.** DO NOT mail the application to the Bureau of Fire Services (BFS). If mailed to the BFS, it will be returned to the sender.



CERTIFICATE OF LIABILITY INSURANCE

DATE (MM/DD/YYYY)

6/22/2023

THIS CERTIFICATE IS ISSUED AS A MATTER OF INFORMATION ONLY AND CONFERS NO RIGHTS UPON THE CERTIFICATE HOLDER. THIS CERTIFICATE DOES NOT AFFIRMATIVELY OR NEGATIVELY AMEND, EXTEND OR ALTER THE COVERAGE AFFORDED BY THE POLICIES BELOW. THIS CERTIFICATE OF INSURANCE DOES NOT CONSTITUTE A CONTRACT BETWEEN THE ISSUING INSURER(S), AUTHORIZED REPRESENTATIVE OR PRODUCER, AND THE CERTIFICATE HOLDER.

IMPORTANT: If the certificate holder is an ADDITIONAL INSURED, the policy(ies) must be endorsed. If SUBROGATION IS WAIVED, subject to the terms and conditions of the policy, certain policies may require an endorsement. A statement on this certificate does not confer rights to the certificate holder in lieu of such endorsement(s).

PRODUCER Acrisure, LLC dba Britton Gallagher & Associates One Cleveland Center, Floor 30 1375 East 9th Street Cleveland OH 44114	CONTACT NAME: PHONE (A/C, No., Ext): 216-658-7100 FAX (A/C, No.): 216-658-7101 E-MAIL ADDRESS: info@brittongallagher.com	
	INSURER(S) AFFORDING COVERAGE INSURER A : Everest Indemnity Insurance Co. NAIC # 10851 INSURER B : Everest Denali Insurance Company 16044 INSURER C : Arch Speciality Ins Co 21199 INSURER D : Continental Indemnity Company 28258 INSURER E : INSURER F :	
INSURED Pyrotecnico Fireworks Inc. P.O. Box 149 299 Wilson Road New Castle PA 16103	2299	

COVERAGES

CERTIFICATE NUMBER: 125837020

REVISION NUMBER:

THIS IS TO CERTIFY THAT THE POLICIES OF INSURANCE LISTED BELOW HAVE BEEN ISSUED TO THE INSURED NAMED ABOVE FOR THE POLICY PERIOD INDICATED. NOTWITHSTANDING ANY REQUIREMENT, TERM OR CONDITION OF ANY CONTRACT OR OTHER DOCUMENT WITH RESPECT TO WHICH THIS CERTIFICATE MAY BE ISSUED OR MAY PERTAIN, THE INSURANCE AFFORDED BY THE POLICIES DESCRIBED HEREIN IS SUBJECT TO ALL THE TERMS, EXCLUSIONS AND CONDITIONS OF SUCH POLICIES. LIMITS SHOWN MAY HAVE BEEN REDUCED BY PAID CLAIMS.

INSR LTR	TYPE OF INSURANCE	ADDL SUBR INSR	WVD	POLICY NUMBER	POLICY EFF (MM/DD/YYYY)	POLICY EXP (MM/DD/YYYY)	LIMITS
A	GENERAL LIABILITY <input checked="" type="checkbox"/> COMMERCIAL GENERAL LIABILITY <input type="checkbox"/> CLAIMS-MADE <input checked="" type="checkbox"/> OCCUR GEN'L AGGREGATE LIMIT APPLIES PER: <input type="checkbox"/> POLICY <input checked="" type="checkbox"/> PRO-JECT <input type="checkbox"/> LOC	Y	Y	S18ML00891-231	1/14/2023	10/14/2023	EACH OCCURRENCE \$ 1,000,000 DAMAGE TO RENTED PREMISES (Ea occurrence) \$ 500,000 MED EXP (Any one person) \$ PERSONAL & ADV INJURY \$ 1,000,000 GENERAL AGGREGATE \$ 2,000,000 PRODUCTS - COMP/OP AGG \$ 2,000,000 \$
B	AUTOMOBILE LIABILITY <input checked="" type="checkbox"/> ANY AUTO <input type="checkbox"/> ALL OWNED AUTOS <input type="checkbox"/> SCHEDULED AUTOS <input checked="" type="checkbox"/> HIRED AUTOS <input checked="" type="checkbox"/> NON-OWNED AUTOS	Y	Y	S18CA00141-231	1/14/2023	10/14/2023	COMBINED SINGLE LIMIT (Ea accident) \$ 1,000,000 BODILY INJURY (Per person) \$ BODILY INJURY (Per accident) \$ PROPERTY DAMAGE (Per accident) \$ \$
C	UMBRELLA LIAB <input checked="" type="checkbox"/> OCCUR <input checked="" type="checkbox"/> EXCESS LIAB <input type="checkbox"/> CLAIMS-MADE DED RETENTION \$	Y	Y	UXP1035252-03	1/14/2023	10/14/2023	EACH OCCURRENCE \$ 4,000,000 AGGREGATE \$ 4,000,000 \$
D	WORKERS COMPENSATION AND EMPLOYERS' LIABILITY ANY PROPRIETOR/PARTNER/EXECUTIVE OFFICER/MEMBER EXCLUDED? (Mandatory in NH) If yes, describe under DESCRIPTION OF OPERATIONS below	Y	N/A	82-872096-04-33	6/7/2023	6/7/2024	<input checked="" type="checkbox"/> WC STATUTORY LIMITS OTH-ER E.L. EACH ACCIDENT \$ 1,000,000 E.L. DISEASE - EA EMPLOYEE \$ 1,000,000 E.L. DISEASE - POLICY LIMIT \$ 1,000,000
A	Excess Liability #2	Y	Y	S18EX01314-231	1/14/2023	10/14/2023	Each Occ/ Aggregate \$5,000,000 Total Limits \$10,000,000

DESCRIPTION OF OPERATIONS / LOCATIONS / VEHICLES (Attach ACORD 101, Additional Remarks Schedule, if more space is required)

Additional Insured extension of coverage is provided by above referenced General Liability policy where required by written agreement.

FIREWORKS DISPLAY DATE: August 4, 2023

LOCATION: St. Clair River Marine City, MI

ADDITIONAL INSURED; City of Marine City 260 S. Parker Marine City MI 48039;

Marine City Area Fire Dept. 200 S. Parker South Parker Marine City MI 48039

CERTIFICATE HOLDER**CANCELLATION**

Marine City Festival
 PO Box 129
 Marine City MI 48039

SHOULD ANY OF THE ABOVE DESCRIBED POLICIES BE CANCELLED BEFORE THE EXPIRATION DATE THEREOF, NOTICE WILL BE DELIVERED IN ACCORDANCE WITH THE POLICY PROVISIONS.

AUTHORIZED REPRESENTATIVE

© 1988-2010 ACORD CORPORATION. All rights reserved.

Maritime Days Festival
St. Clair River, Marine City MI

Pyrotechnico Fireworks Inc.
5/25/2023 Michael Falk

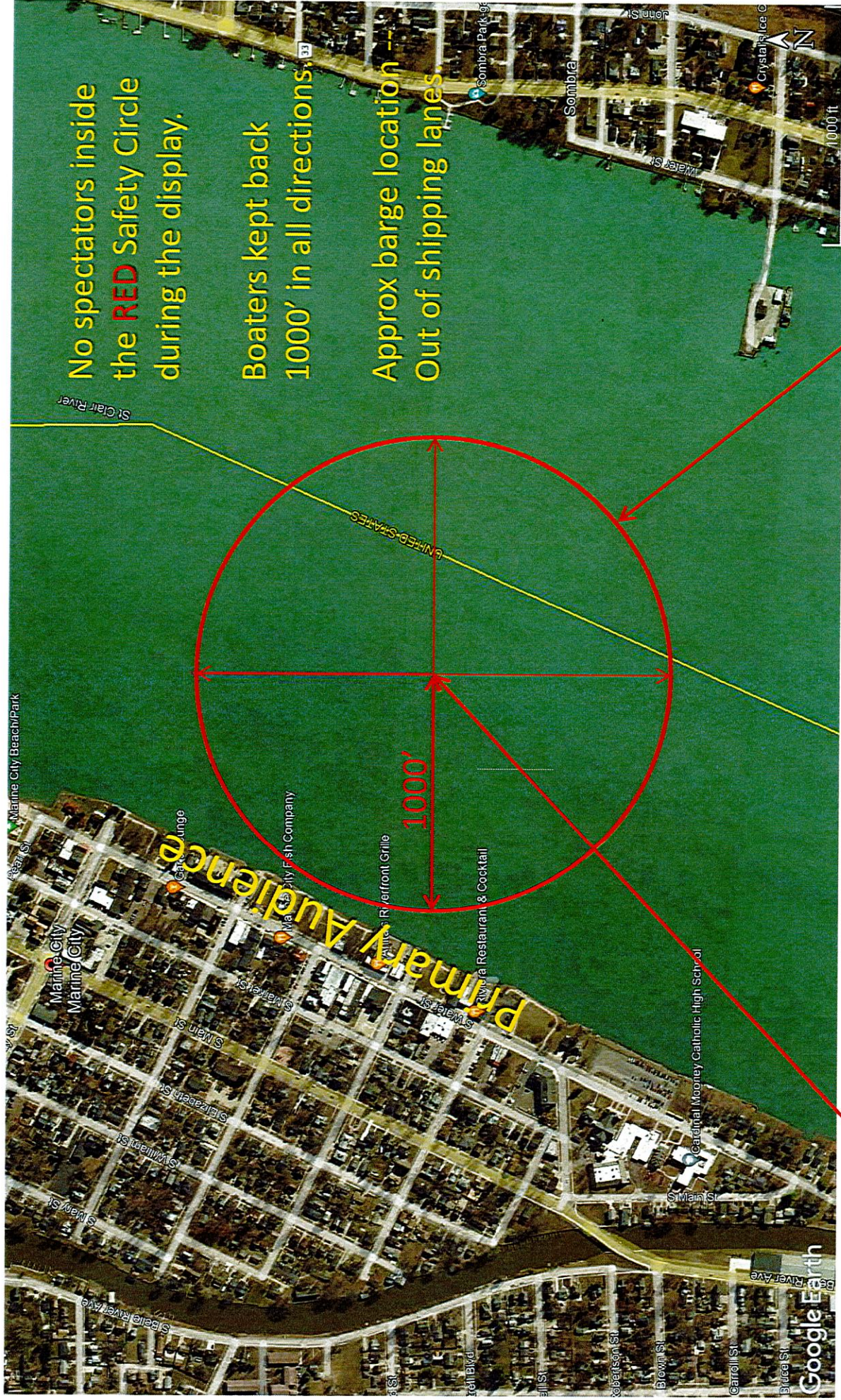

Launch Location

Setup area: 25' X 100'

Radius from setup area: 1000'



AGENDA MEMO

TO: Mayor and City Commission
FROM: City Manager Scott Adkins
SUBJECT: **Approval of 457 Plan Resolution designating City Manager as Authorized Plan Administrator and Katy Posey as Authorized Plan Trustee**

BACKGROUND INFORMATION: Based upon recent personnel changes within the City, it is necessary that we make changes to the authorized plan administrator and plan trustee to the Nationwide 457 Deferred Compensation Plan. Nationwide requires adoption of a resolution by the local governing body to make such changes.

ORIGINATING DEPARTMENT: City Manager's Office

BUDGETED ITEM: Yes

REVIEWED BY: S. Adkins

STAFF RECOMMENDATION

PRESENTED BY: S. Adkins

RECOMMENDED ACTION(s): Motion to designate City Manager Scott Adkins as the primary employer authorized representative and plan administrator and Treasurer/Finance Director Katy Posey as plan trustee for the City-sponsored 457 Plan.

DATE APPROVED FOR AGENDA: July 20, 2023

ATTACHMENTS: Authorization Resolution and related plan documents

ADOPTING RESOLUTION

The undersigned authorized representative of City of Marine City (the Employer) hereby certifies that the following resolutions were duly adopted by the Employer on _____, and that such resolutions have not been modified or rescinded as of the date hereof:

RESOLVED, that the form of amended 457 Plan and Trust effective June 12, 2023, presented to this meeting is hereby approved and adopted and that an authorized representative of the Employer is hereby authorized and directed to execute and deliver to the Administrator of the Plan one or more counterparts of the Plan.

The undersigned further certifies that attached hereto as Exhibits A and B, respectively, are true copies of City of Marine City 457(b) Retirement Plan as amended and restated and the Summary of 457 Provisions, which are hereby approved and adopted.

Date: _____

Signed: _____

[print name/title]

This Plan is executed on the date(s) specified below.

Use of Adoption Agreement. Failure to complete properly the elections in this Adoption Agreement may result in disqualification of the Employer's Plan. The Employer only may use this Adoption Agreement only in conjunction with the corresponding basic plan document.

EMPLOYER: City of Marine City

By: _____

Scott Adkins

TRUSTEE

DATE SIGNED

DATE SIGNED

6. **Determination order is not a QDRO.** If the Plan Administrator determines the order is not a QDRO:
- a. The Plan Administrator will advise the participant and each alternate payee of the adverse decision and of the reasons for the adverse decision. The Plan will advise the participant and each alternate payee of the decision within ten days of the determination by mailing to each party a copy of the QDRO DETERMINATION CHECKLIST, which will include the Plan Administrator's certification of the decision.
 - b. The Plan Administrator will discontinue separate accounting for the amounts payable under the order. The Plan will pay the benefits to the party entitled to receive the benefits. If the participant is not entitled to a present distribution of any of the segregated benefits, the Plan will continue to account for the participant's benefits as if the Plan had not received the order.
 - c. If the Plan Administrator determines the status of the order within the 18-month period beginning on the date the order would require the first payment, the Plan Administrator may delay distribution of any benefits subject to the order if the Plan Administrator has reason to believe a party will seek to cure the defects in the order. The Plan Administrator will continue to delay distribution during the period the Plan Administrator determines to be necessary to fulfill the Plan Administrator's duties under the Plan.
7. **Consultation with legal counsel.** The Plan Administrator will consult with the Plan's legal counsel in case of questions which arise with respect to the interpretation of any provision of the order or with respect to the qualified status of the order.

Signature of Plan Administrator
City of Marine City 457(b) Retirement Plan



AGENDA MEMO

TO: Mayor and City Commission
FROM: City Manager Scott Adkins
SUBJECT: **Annual Property and Casualty Insurance Policy Renewal**

BACKGROUND INFORMATION: Annually, the City's insurance coverages are reviewed and a renewal proposal is prepared for Commission approval. This year, the same process was followed as in the past and a renewal proposal developed. Costs have increased for 2023 insurance coverage by slightly over \$11,000. Increases are indicated on the attached correspondence, however in summary, the majority increases can be attributed to an increase in our annual budget expenditures (based on increase in taxable value), increase in building and property values and the addition of 2 new police vehicles to the motor pool. Overall we have been pleased with the service provided by our agent and various carriers providing coverage to the City.

ORIGINATING DEPARTMENT: City Manager's Office

BUDGETED ITEM: Yes

REVIEWED BY: S. Adkins

STAFF RECOMMENDATION

PRESENTED BY: S. Adkins

RECOMMENDED ACTION(s): Motion to accept the annual property and casualty insurance renewal from Nickel & Saph Inc. in the amount of \$133,570.00 as recommended.

DATE APPROVED FOR AGENDA: July 20, 2023

ATTACHMENTS: Renewal Proposal Letter



NICKEL & SAPH, INC.

INSURANCE SINCE 1929

MAILING ADDRESS:

P.O. BOX 46907
MT. CLEMENS, MI 48046-6907

OFFICE ADDRESS:

44 MACOMB PLACE
MT. CLEMENS, MI 48043
(586) 463-4573 • (810) 765-8887
1-800-657-7373 • FAX: (586) 463-3135
www.nickelsaph.com

June 23, 2023

Mr. Scott Adkins
City of Marine City
260 S. Parker Street
Marine City, MI 48039

Re: Property and Casualty Insurance Renewal Proposal

Dear Mr. Adkins:

We are pleased to present our renewal proposal for coverages underwritten by Trident Public Risk Solutions, a member of Paragon Insurance Holdings, LLC. The affording carriers are: Argonaut Insurance (for liability and automobile coverages). Argonaut has been awarded an A.M. Best's rating of A- XIII, Stable; Arch Insurance Company (for property and crime coverages). Arch has been awarded an A. M. Best's rating of A+ XV, Stable; and Hartford Steam Boiler (for mechanical breakdown coverages). Hartford has been awarded an A. M. Best's rating of A++ XI, Stable. All three carriers are admitted carriers in the State of Michigan. Trident specializes in providing risk management and insurance products and services only to public entities. Trident writes over \$150,000,000 in premiums on an annual basis throughout the eastern, southern, and midwestern states, including many public entities in Michigan. Of the various public entities within the State of Michigan, over one-hundred and thirty (130) are currently insured with Trident.

The total annual renewal premium is \$133,570. The expiring annual premium was \$122,565. The renewal premium reflects an increase of \$11,005 or 8.98%.

Factors impacting the development of the renewal premium:

- Net rateable expenditures have increased from \$2,179,511 to \$2,244,715, an increase of \$65,204 or 3%.
- Property values have increased from \$33,762,881 to \$35,160,535, an increase of \$1,397,654 or 4%.
- Inland Marine values have increased from \$777,142 to 806,330, an increase of \$29,188 or 3.76%.
- The number of insured vehicles has increased from 16 units to 18, an increase of 12.5%, and the corresponding automobile physical damage values have increased from \$1,190,586 to \$1,270,860, an increase of \$80,274 or 6.74%.

- Since July of 2021 (first date coverage place with Trident), three claims have been reported. One is closed and two are still pending. The total incurred value is \$64,220 which develops a 28.23% loss ratio.

The proposed coverage includes Terrorism Risk Insurance. The annual terrorism premium (included above) is \$2,383. The original federal Terrorism Risk Insurance Act has been amended to include both foreign and domestic terrorist acts. We recommend that this elective coverage be secured by the city. Annually, you must declare whether the city accepts or rejects this coverage.

Please note the following regarding the Trident proposal:

- 1.) All liability coverages are written on an occurrence basis. Covered Automobile Liability claims are subject to zero or no deductible. The remaining liability lines (General Liability, Public Officials', Law Enforcement, and Employment Practices) are subject to \$5,000 deductibles. Deductibles apply to both expenses and damages.
- 2.) As an enhancement, Trident provides \$10,000,000 (full limits) for Sudden and Accidental Failure to Supply, Limited Pollution Liability (limited to Property Damage), and Liability from Back-up of Sewers.
- 3.) As an enhancement, Trident's Excess Liability Coverage provides separate limits or towers per occurrence and aggregate over the following: General Liability, Public Officials' Liability, Employment Practices Liability, Law Enforcement Liability, and Automobile Liability (underlying Auto Liability is not subject to an aggregate). Payment of claims attributed to one line of coverage will not reduce or impact the limits dedicated to the remaining four lines of coverage.
- 4.) As an enhancement, Trident provides liability coverage for Inverse Condemnation for limits of \$100,000 per occurrence and \$300,000 aggregate and Injunctive Relief for limits of \$10,000 per occurrence and \$50,000 aggregate. Defense expenses for Inverse Condemnation claims are separate from the limits afforded for the payment of damages (the payment of defense expenses will not reduce the limits afforded for the payment of damages).
- 5.) All property and inland marine coverages are written on a replacement cost basis with the exception of the old city hall, the Guy Center, the lighthouse, and the museum buildings, which, due to age, are covered on an actual cash value basis.
- 6.) Trident allows the city the opportunity to recommend legal counsel of the city's choosing for the defense of all covered liability claims. Defense counsel must demonstrate prior experience defending public entities.

Limited Data Compromise and Cyber coverages are afforded. We are confident that you are aware of recent news reports related to cyber-crimes that have increasingly plagued municipalities and private businesses throughout the country. The proposed coverage is a hybrid policy form in that two forms of coverage are proposed: first party coverage for claims that directly impact the city and coverage for damages that the city may become legally liable to third-party individuals. Please refer to pages three and four of the enclosed Trident/Argonaut proposal for a summary of the proposed Data Compromise and Cyber coverages.

The annual premium for the cyber coverages, \$2,933, is included in the annual premium that is declared above. The aggregate amount of coverage is \$250,000. Covered claims are subject to a \$2,500 deductible. Coverage is afforded on a Claims Made basis. The afforded coverages are: Data Compromise Response Expense; Data Compromise Liability; Cyber Attack & Cyber Extortion; Network Security Liability; and Electronic Media Liability.

This is a basic coverage form. Should the city adopt protections such as multi-factor authentication for authorized user access, we could secure quotes with both higher limits and additional, broader coverages.

The servicing address for all policy and claims related issues continues to be 44 Macomb Place, Mount Clemens, MI 48043 (our agency's office). The premium includes all claim services and loss prevention and safety inspections.

This year, we have contracted the services of HCA Asset Management Company for the purpose of making physical inspections of all city owned buildings and structures. The result of the inspections will be used to confirm accurate underwriting information and develop current replacement values for all buildings, contents, and property in the open. We are undertaking this effort due to the continued concerns related to the impact of inflation on materials and labor. In order to enjoy replacement cost provisions for covered property claims, an insured must insure the covered property for replacement values. Nickel & Saph is incurring the expense for the inspections. Any resulting change to the property values will be accompanied by a premium adjustment (premium based on the rates fixed for this year).

Enclosed, please find a detailed copy of the Trident proposal. We are anxious and available to meet with yourself or any other members of the city's administration to answer any questions. Thank you.

Sincerely,



Stephen R. Saph, Jr., LIC
Agent

Enclosures

All insurance policies contain exclusions and limitations either within the policy language or added to the policy by attachment of an endorsement. Not all exclusions or limitations are addressed in this proposal. Exclusions and limitations can be absolute or conditional based on the specific circumstances and allegations of a loss or claim. Policy language dictates coverage. Nickel & Saph, Inc. offers the coverage options available from the insurance carriers it is licensed to represent or from those with which it has a relationship; the agency makes no representations regarding coverages, exclusions, or limitations in policies from any carriers not represented by the agency nor does the agency make representations regarding the availability of coverage to cover any specific risk of loss in the broader insurance marketplace.

Irrevocable Pledge

Participant extends a non-home loan having a five year or less repayment term beyond five years, the balance of the loan at the time of the extension is a taxable distribution to the Participant.

4. **SECURITY FOR LOAN.** The Plan will require that adequate security be provided by the Participant before a loan is granted. For this purpose, the Plan will consider a Participant's interest under the Plan (account balance) to be adequate security. However, in no event will more than 50% of a Participant's vested interest in the Plan (determined immediately after origination of the loan) be used as security for the loan. Generally, it will be the policy of the Plan not to make loans which require security other than the Participant's vested interest in the Plan. However, if additional security is necessary to adequately secure the loan, then the Plan Administrator will require that such security be provided before the loan will be granted.

5. **FORM OF PLEDGE.** The pledge and assignment of a Participant's account balances will be in the form prescribed by the Plan Administrator.

6. **LEAVE OF ABSENCE/SUSPENSION OF PAYMENT.** The Plan Administrator will suspend loan repayments for a period not exceeding one year which occurs during an approved leave of absence, either without pay from the Employer or at a rate of pay (after applicable employment tax withholdings) that is less than the amount of the installment payments required under the terms of the loan. The Plan Administrator will provide the Participant with a written explanation of the effect of the leave of absence upon his or her Plan loan.

7. **PAYMENTS AFTER LEAVE OF ABSENCE.** When payments resume following a payment suspension in connection with a leave of absence authorized above, the Participant will select one of the following methods to repay the loan, plus accumulated interest:

- The Participant will increase the amount of the required installments to an amount sufficient to amortize the remaining balance of the loan, plus accrued interest, over the remaining term of the loan.
- The Participant will pay a balloon payment of the remaining unpaid principal and interest, at the conclusion of the term of the loan as determined in the promissory note.
- The Participant may extend the maturity of the loan and re-amortize the payments over the remaining term of the loan. In no event will the amount of the adjusted installment payment be less than the amount of the installment payment provided under the promissory note. In the case of a non-military leave of absence, the revised term of the loan will not exceed the maximum term permitted under item 3 above. In the case of a military leave of absence, the revised term of the loan will not exceed the maximum term permitted under item 3 above, augmented by the time the Participant was actually in United States military service.

8. **DEFAULT.** The Plan Administrator will treat a loan as in default if:

- any scheduled payment remains unpaid beyond the last day of the calendar quarter following the calendar quarter in which the Participant missed the scheduled payment

Upon default, the Participant will have the opportunity to repay the loan, resume current status of the loan by paying any missed payment plus interest or, if distribution is available under the Plan, request distribution of the note. If the loan remains in default, the Plan Administrator will offset the Participant's vested account balances by the outstanding balance of the loan to the extent permitted by law. The Plan Administrator will treat the note as repaid to the extent of any permissible offset. Pending final disposition of the note, the Participant remains obligated for any unpaid principal and accrued interest.

9. **FEES.** If you apply for a loan, you will be charged for Plan expenses associated with the loan. The application fee (including processing and document preparation) is \$150. All fees are subject to change.

Adopted this _____ day of _____, 20____. This loan policy may be amended from time to time.

Signature of Plan Administrator
City of Marine City 457(b) Retirement Plan
Borrower

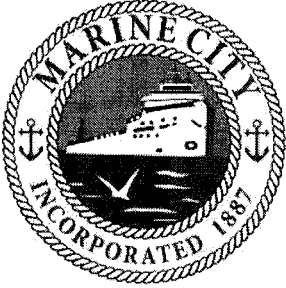

AGENDA MEMO

TO: Mayor and City Commission
FROM: City Manager Scott Adkins
SUBJECT: **Request Approval of Contract for City Clerk-Jason Bell**

BACKGROUND INFORMATION:

I have received a letter of interest from Jason Bell requesting to be considered for the vacant City Clerk position. After a review of Mr. Bell's employment history with the City as well as his service to the City as the Interim Clerk for the past several months, I have no hesitation in recommending him for this full time position and I am confident that he will be a great asset to the City in this position. A draft employment agreement has been prepared and reviewed by the City Attorney.

ORIGINATING DEPARTMENT: City Manager's Office

REVIEWED BY: S. Adkins

BUDGETED ITEM: Yes

STAFF RECOMMENDATION

PRESENTED BY: S. Adkins

RECOMMENDED ACTION(s): Motion to approve the employment agreement between the City of Marine City and Jason Bell as presented.

DATE APPROVED FOR AGENDA: July 20, 2023

ATTACHMENTS: Draft Employment Agreement

CITY CLERK AT WILL EMPLOYMENT AGREEMENT

This City Clerk At Will Employment Agreement (“Agreement”), made this 20th day of July, 2023, between the City of Marine City, a Michigan Municipal Corporation, (“City”), located at 260 S. Parker Street, Marine City, Michigan 48039 and Jason Bell, hereafter referred to as “Employee”, and states the following:

WITNESSETH:

WHEREAS, the City is a duly created Michigan Municipal Corporation in good standing; and

WHEREAS, the Employee wishes to be employed by the City as the City Clerk and submitted a written letter indicating a request to hold the position of City Clerk; and

WHEREAS, the Employee represents to the City that Employee has the general skills, experience and general know how to perform the duties of the City Clerk and has no current employment conflicts with accepting the position of City Clerk as set forth herein, including any conflicts, legal or otherwise, with any currently held elected or appointed office; and

WHEREAS, the City wishes to employ the services of the Employee as the City Clerk under the terms and provisions set forth herein; and

WHEREAS, the Employee shall serve at the pleasure of the City Manager and shall be, for all legal purposes, an “at will” Employee subject to the City Charter, including any future amendments to the City Charter that governs the employment of a City Clerk; and

WHEREAS, the Employee wishes to accept employment as the City Clerk under the terms and conditions set forth herein including the employment status as an “at will” Employee.

NOW, THEREFORE, in consideration of the promises and mutual agreements herein, the parties hereto agree as follows with adequate and full consideration acknowledged and accepted by both the Employee and the City:

1. **At Will Employment Status**: This Agreement shall be effective as of July 20, 2023. The Employee shall serve as the City Clerk reporting directly to the City Manager and otherwise serving as the City Clerk in accordance with the then controlling City Charter. Nothing in this Agreement is intended to create a just cause relationship between the Employee and the City.

Employee may terminate this Agreement for any reason with thirty (30) days written notice to the City. The City may terminate this Agreement for any reason with thirty (30) days written notice to the Employee.

The Employee may return to his previous position with the Marine City Police Department at any time within 12 months of the execution of this Agreement at Employee’s request, provided that the Employee is in good standing with the City and not in violation of any ordinance, policy, or statute. If this option is exercised

by the Employee, upon return to said unit with the Marine City Police Department, longevity, years of service, vacation time and other accrued benefits shall be preserved. This option is only available to Employee for one (1) year, nothing herein prevents Employee from applying for Employee's prior position after the one (1) year time period has expired. Nothing herein binds the City to employ the Employee in the prior position after the one (1) year time period.

2. **Salary:** The City agrees to pay the Employee an annual base salary of sixty-eight thousand dollars and 00/100 (\$68,000.00) Dollars payable in bi-weekly installments on the same dates as other employees of the City are paid. The City shall withhold from each of the foregoing installments the appropriate amount of payroll taxes, including Federal Income Tax, State Income Tax and Medicare Tax as required by the applicable laws and regulations.

Employee, upon completion of each of the following training/certification processes, shall have the annual salary automatically adjusted according to the schedule below without any further action of the City Commission. The City Manager shall review and ensure compliance before any annual base salary adjustment under this provision is implemented.

- Enroll and complete Master Clerk's Certification \$2,500.00

Nothing in this provision prevents the City from considering other interim pay adjustments based on annual reviews and performance of the Employee.

3. **Performance Review:** The City Manager shall conduct an annual performance review of the Employee as the City Clerk annually. This annual review process may result in an increase to the annual base salary.
4. **Employment Expectation.** The Employee has no expectation of the continued employment as the City Clerk and Employee recognizes that Employee is at will and serves as the City Clerk at the sole discretion of the City Manager as set forth herein.
5. **Employment Status:** The Employee acknowledges that Employee is an "exempt salaried" employee under the provisions of the Federal Fair Labor Standards Act (FLSA), and as a result thereof, the Employee is not entitled to accumulate or be paid for any compensatory time off or overtime. The City and the Employee agree that the Employee will be required to devote a great deal of time to City affairs outside normal business/office hours and must attend meetings which may conclude late at night. It is agreed between the City and the Employee that the Employee will use good judgment to determine the need to exercise flex-time to accommodate these instances. For example, but not by way of limitation, after a late meeting, the Employee may find it a hardship to report to work at exactly 7:30 a.m. the next morning, and may adjust the work schedule to obtain optimal job efficiency. The Employee shall keep a personal log of these issues and use of flexible hours to address these types of issues. The

Employee's record of said time shall be subject to monthly review by the City Manager, in the City Manager's sole discretion.

6. **Required Duties of City Clerk:** The Employee, as the City Clerk, shall perform those functions and duties as required by the City Charter and by all applicable laws governing the position of Clerk in a city government structure. The duties of the City Clerk are set forth in controlling City policies, directives or the attached City Clerk Job Description incorporated by reference herein and such duties may change from time to time at the direction of the City Manager. It is the expectation that Core work hours will vary, subject to change at times without notice depending on workload and priorities, however the position is a full-time 40 hour position.
7. **Negotiated Severance Payment:** If Employee is terminated by the City Manager at any time with such termination being affirmed, if required, by the City Commission, the Employee is entitled to a Severance Payment of three (3) months base salary. This Severance Payment is waived and held for naught if the Employee is terminated by the City because the Employee is convicted of any crime, misdemeanor or otherwise, or related in any way to documented malfeasance in office. All standard deductions shall be applied to the Severance Payment amount. For purposes of this provision, base salary shall mean the then applicable base salary. There shall be no severance payment if, at any time, the Employee terminates this Agreement.
8. **Professional Development:** The City may, upon presentation and review, pay the expenses for which the Employee and the City deem necessary for the Employee's continued professional development and for the good of the City. The foregoing expenses may include the cost of travel to attend said conference/seminar, registration, and subsistence of the Employee only, for the employee attendance at the conference/seminar. However, all of the foregoing shall be subject to prior City Commission approval, the prior appropriation of funds for this purpose and current budgetary constraints. Any expenses for attendance at local conferences/seminars and meetings with local governmental officials shall be paid by the Employee and reimbursed to the Employee out of funds specifically appropriated by the City Commission to relevant budgetary accounts for this purpose.
9. **Employee Warranty:** Employee represents and warrants that all information provided in the Application, Resume and Interview process concerning educational background and history, attendance at specific universities and matriculation to specific degrees is accurate. Employee understands that any misrepresentation concerning these matters will render this contract null and void.
10. **Indemnification:** The City shall defend, hold harmless and indemnify, by and through its insurance carrier or otherwise, the Employee against any unintentional tort or other like legal action, professional liability claim or demand or other legal action, whether groundless or otherwise, arising out of an alleged act or omission occurring within the scope of this employment as City Clerk. The

City or its insurance carrier shall pay the amount of any settlement or judgment rendered thereon, if any, so long as the claim arises out of an alleged act of error or omission occurring within the scope of the City Clerk's employment as City Clerk.

11. General Benefits:

- a. Pension and Retirement: Employee shall be enrolled into the City's 457 plan. The City will match dollar for dollar on the first five-percent (5%) of salary contributions made by the Employee.
- b. Health and Life Insurance Benefits: Employee shall receive the same level of benefits, as provided to all other City exempt employees.
- c. Employment Expenses: The City shall upon request and with the submittal of all appropriate and supporting documentation, reimburse Employee for all reasonable employment-related expenses; including, but not limited to mileage, travel expenses, and lodging, pursuant to the City's policies concerning said expenses as they currently exist, or as they may be amended or modified during the term of this Agreement.
- d. Cell phone: Employee shall receive a Forty Dollar (\$40.00) monthly cell phone allowance.
- e. Technology Stipend: Employee shall receive Five Hundred Dollars (\$500.00) annually, payable upon execution of this agreement, then each July for technology related expenses such as computer/tablet, miscellaneous communication hardware and the like.

12. Vacation and Sick Time: Employee shall receive vacation and sick time in accordance with City of Marine City Personnel Policies and Procedures Manual in place and as amended in the future.

13. General Provisions:

- a. This Agreement constitutes a single, integrated, written Agreement expressing the entire agreement between the parties. There are no other agreements, written or oral, express or implied, between the parties hereto related to these matters.
- b. This Agreement embodies the whole Agreement between the parties and there are no inducements, promises, terms, conditions or obligations made or entered into by either party other than as contained herein.
- c. No modification of this Agreement shall be valid unless such modification is in writing and signed by the City and Employee. No waiver of any provision of this Agreement shall be valid unless such modification is in writing and signed by both parties.

- d. This Agreement shall be binding upon and inure to the benefit of the successors and assigns of the City and the Employee.
- e. If any provision, or portion thereof, contained in this Agreement is held unconstitutional, invalid, unenforceable, or contrary to IRS Code/Rules, the remainder of the Agreement or portion thereof, shall be deemed severable, and shall not be affected and shall remain in full force and effect.
- f. This Agreement shall be governed by the laws of the State of Michigan, City of Marine City, City Charter and applicable Code of Ordinances.
- g. This Agreement shall become effective upon ratification of a majority of City Commission.
- h. The terms of this Agreement are not to be construed against either party in the event of a Court finding an ambiguity as it is deemed to be a mutually drafted agreement.
- i. In the event of an impasse regarding this Agreement or any of its stated terms of employment, both parties agree to submit to binding arbitration, with each party paying one-half of the costs.

IN WITNESS WHEREOF, the City of Marine City has caused this Agreement to be signed and executed on its behalf by its Mayor and the Employee has signed and executed this Agreement, the day and year first above written.

**CITY OF MARINE CITY
a Michigan Municipal Corporation**

By: _____
Its: Mayor

Dated: _____

“EMPLOYEE”

/s/ _____

Dated: _____



CITY OF MARINE CITY

BOARDS AND COMMISSIONS APPLICATION

Name of Applicant: MADLYN Mc CARTHY

Address: [Redacted]

Telephone: [Redacted]

Email: [Redacted]

RECEIVED

MAY 11 2023

City of Marine City

Indicate below which you are interested in serving on (may select more than one):

CITY COMMISSION

PLANNING COMMISSION

BOARD OF REVIEW

HISTORICAL COMMISSION

LIBRARY BOARD

M.C.A.F.A.

T.I.F.A.

ZONING BOARD OF APPEALS

COMMUNITY & ECONOMIC DEVELOPMENT

DANGEROUS BUILDING BOARD OF APPEALS

Please answer the following:

- | | Yes | No |
|---|-------------------------------------|-------------------------------------|
| • Are you a Resident of the City of Marine City | <input checked="" type="checkbox"/> | <input type="checkbox"/> |
| • Are you a Registered Elector of the City of Marine City | <input checked="" type="checkbox"/> | <input type="checkbox"/> |
| • Are you in default to the City (Taxes, Water Bills, Etc) | <input type="checkbox"/> | <input checked="" type="checkbox"/> |
| • Are you in violation to the City (Blight, Building, Code, Etc.) | <input type="checkbox"/> | <input checked="" type="checkbox"/> |
| • Are you a State registered Architect or Engineer | <input type="checkbox"/> | <input checked="" type="checkbox"/> |
| • Are you a Building Contractor | <input type="checkbox"/> | <input checked="" type="checkbox"/> |
| • Are you currently employed by the City | <input type="checkbox"/> | <input checked="" type="checkbox"/> |

Comment on your area of interest and your experience in the community.
Feel free to attach additional pages or a resume.

Madelyn A. McCarthy
(Signature)

May 10, 2023
(Date)

PLEASE RETURN COMPLETED APPLICATION TO THE CITY CLERK



CITY OF MARINE CITY

BOARDS AND COMMISSIONS APPLICATION

Name of Applicant: WILLIAM BEUTEL

Address: _____

Telephone: _____

Email: _____

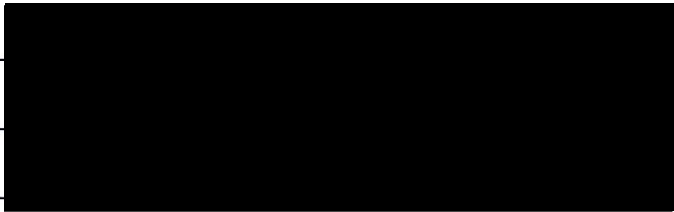

RECEIVED

MAY 10 2023

City of Marine City

Indicate below which you are interested in serving on (may select more than one):

CITY COMMISSION

PLANNING COMMISSION

BOARD OF REVIEW

HISTORICAL COMMISSION

LIBRARY BOARD

M.C.A.F.A.

T.I.F.A.

ZONING BOARD OF APPEALS

COMMUNITY & ECONOMIC DEVELOPMENT

DANGEROUS BUILDING BOARD OF APPEALS

Please answer the following:

- | | Yes | No |
|---|-------------------------------------|-------------------------------------|
| • Are you a Resident of the City of Marine City | <input checked="" type="checkbox"/> | <input type="checkbox"/> |
| • Are you a Registered Elector of the City of Marine City | <input checked="" type="checkbox"/> | <input type="checkbox"/> |
| • Are you in default to the City (Taxes, Water Bills, Etc) | <input type="checkbox"/> | <input checked="" type="checkbox"/> |
| • Are you in violation to the City (Blight, Building, Code, Etc.) | <input type="checkbox"/> | <input checked="" type="checkbox"/> |
| • Are you a State registered Architect or Engineer | <input type="checkbox"/> | <input checked="" type="checkbox"/> |
| • Are you a Building Contractor | <input type="checkbox"/> | <input checked="" type="checkbox"/> |
| • Are you currently employed by the City | <input type="checkbox"/> | <input checked="" type="checkbox"/> |

Comment on your area of interest and your experience in the community.
Feel free to attach additional pages or a resume.

CURRENT MEMBER

William Beutel
(Signature)

5/10/23
(Date)

PLEASE RETURN COMPLETED APPLICATION TO THE CITY CLERK



CITY OF MARINE CITY

BOARDS AND COMMISSIONS APPLICATION

Name of Applicant: GRAHAM P. ALLAN

Address: _____

Telephone: _____

Email: _____

RECEIVED

MAY 09 2023

Indicate below which you are interested in serving on (may select more than one):

CITY COMMISSION

PLANNING COMMISSION

BOARD OF REVIEW

HISTORICAL COMMISSION

LIBRARY BOARD

M.C.A.F.A.

T.I.F.A.

ZONING BOARD OF APPEALS

COMMUNITY & ECONOMIC DEVELOPMENT

DANGEROUS BUILDING BOARD OF APPEALS

Please answer the following:

Yes No

- Are you a Resident of the City of Marine City
- Are you a Registered Elector of the City of Marine City
- Are you in default to the City (Taxes, Water Bills, Etc)
- Are you in violation to the City (Blight, Building, Code, Etc.)
- Are you a State registered Architect or Engineer
- Are you a Building Contractor
- Are you currently employed by the City

Comment on your area of interest and your experience in the community.
Feel free to attach additional pages or a resume.

I HAVE SERVED MULTIPLE TERMS ON THE ABOVE BOARDS & COMMISSIONS.

(Signature)

5/9/2023
(Date)

PLEASE RETURN COMPLETED APPLICATION TO THE CITY CLERK



CITY OF MARINE CITY

11e(ii)

BOARDS AND COMMISSIONS APPLICATION

Name of Applicant: Craig May

Address: [Redacted]

Telephone: [Redacted]

Email: [Redacted]

Indicate below which you are interested in serving on (may select more than one):

CITY COMMISSION

PLANNING COMMISSION

BOARD OF REVIEW

HISTORICAL COMMISSION

LIBRARY BOARD

M.C.A.F.A.

T.I.F.A.

ZONING BOARD OF APPEALS

COMMUNITY & ECONOMIC DEVELOPMENT

DANGEROUS BUILDING BOARD OF APPEALS

Please answer the following:

- | | Yes | No |
|---|-------------------------------------|-------------------------------------|
| • Are you a Resident of the City of Marine City | <input checked="" type="checkbox"/> | <input type="checkbox"/> |
| • Are you a Registered Elector of the City of Marine City | <input checked="" type="checkbox"/> | <input type="checkbox"/> |
| • Are you in default to the City (Taxes, Water Bills, Etc) | <input type="checkbox"/> | <input checked="" type="checkbox"/> |
| • Are you in violation to the City (Blight, Building, Code, Etc.) | <input type="checkbox"/> | <input checked="" type="checkbox"/> |
| • Are you a State registered Architect or Engineer | <input type="checkbox"/> | <input checked="" type="checkbox"/> |
| • Are you a Building Contractor | <input type="checkbox"/> | <input checked="" type="checkbox"/> |
| • Are you currently employed by the City | <input type="checkbox"/> | <input checked="" type="checkbox"/> |

Comment on your area of interest and your experience in the community.
Feel free to attach additional pages or a resume.

I have served on TIFA for about 10 years and would like to continue to serve as we try to develop new plans

Craig May
(Signature)

5/10/2023
(Date)

PLEASE RETURN COMPLETED APPLICATION TO THE CITY CLERK

RECEIVED

MAY 15 2023

City of Marine City



CITY OF MARINE CITY

11e(iii)

BOARDS AND COMMISSIONS APPLICATION

RECEIVED

APR 13 2023

City of Marine City

Name of Applicant: DAVID M. WARNER

Address: [Redacted]

Telephone: [Redacted]

Email: [Redacted]

Indicate below which you are interested in serving on (may select more than one):

- CITY COMMISSION
- BOARD OF REVIEW
- LIBRARY BOARD
- T.I.F.A.
- COMMUNITY & ECONOMIC DEVELOPMENT
- DANGEROUS BUILDING BOARD OF APPEALS
- PLANNING COMMISSION
- HISTORICAL COMMISSION
- M.C.A.F.A.
- ZONING BOARD OF APPEALS

Please answer the following:

- | | Yes | No |
|---|-------------------------------------|-------------------------------------|
| • Are you a Resident of the City of Marine City | <input checked="" type="checkbox"/> | <input type="checkbox"/> |
| • Are you a Registered Elector of the City of Marine City | <input checked="" type="checkbox"/> | <input type="checkbox"/> |
| • Are you in default to the City (Taxes, Water Bills, Etc) | <input type="checkbox"/> | <input checked="" type="checkbox"/> |
| • Are you in violation to the City (Blight, Building, Code, Etc.) | <input type="checkbox"/> | <input checked="" type="checkbox"/> |
| • Are you a State registered Architect or Engineer | <input type="checkbox"/> | <input checked="" type="checkbox"/> |
| • Are you a Building Contractor | <input type="checkbox"/> | <input checked="" type="checkbox"/> |
| • Are you currently employed by the City | <input type="checkbox"/> | <input checked="" type="checkbox"/> |

Comment on your area of interest and your experience in the community.
Feel free to attach additional pages or a resume.

Business Owner

David Warner
(Signature)

4/17/23
(Date)

PLEASE RETURN COMPLETED APPLICATION TO THE CITY CLERK

DAVID M. WARNER

SUMMARY OF QUALIFICATIONS

Senior communications professional with more than 30 years of experience in strategic communications and public-policy issues advocacy. Broad background in news and editorial writing and editing, media relations, public-policy issues campaigns, social media content.

PROFESSIONAL EXPERIENCE

WARNER PUBLIC AFFAIRS

2021 - Present

➤ **President**

- Provide communications support and strategic counsel to agricultural clients.
- Write congressional testimony, speeches, talking points, issue papers, and op-eds for organizations.
- Produce weekly legislative email newsletter and bimonthly legislative magazine for National Pork Producers Council.

U.S. DEPARTMENT OF AGRICULTURE, Washington, D.C.

2019 - 2021

➤ **Director of External Affairs**

- Directed communications and legislative and stakeholder relations for USDA's Farm Production and Conservation mission area and supported Under Secretary Bill Northey.
- Wrote speeches, talking points, issues backgrounders for Under Secretary.
- Oversaw mission area's web and digital strategy, public affairs, media relations, congressional engagement and intergovernmental and partnership relations.

NATIONAL PORK PRODUCERS COUNCIL, Washington, D.C.

2005 - 2019

➤ **Director of Communications and Spokesman**

- Helped direct public-policy communications, developed communications strategies for agricultural association.
- Served as association spokesman to the media; pitched stories to reporters.
- Wrote and edited organization communications, including issue papers, congressional testimony, and remarks and speeches for association CEO and board officers.
- Wrote bimonthly, weekly legislative updates; produced daily news digest.
- Wrote press releases, letters-to-the-editor, articles, and op-eds, which have appeared in, among other publications, the *Wall Street Journal*, *New York Times*, *USA Today*, *Des Moines Register*, *Cleveland Plain-Dealer*, *Roll Call*, *The Hill* and *Daily Caller*.
- Helped develop advocacy communications campaigns, including ones on the Trans-Pacific Partnership, USMCA, and "GIPSA" Rule.
- Redesigned Website and edited content.

JUDICIAL WATCH, Washington, D.C.

2003 - 2005

➤ **Director of Media Relations and Spokesman**

- Ran communications program for \$12 million government watchdog organization.
- Developed and implemented strategic public relations plan to raise profile of organization.
- Wrote remarks, talking points, press releases, and op-eds for organization president.
- Pitched stories to media and served as press spokesman.

U.S. CHAMBER INSTITUTE FOR LEGAL REFORM, Washington, D.C.

2002 - 2003

➤ **Director of Communications, Senior Editor and Spokesman**

- Ran communications program for \$40 million legal reform organization.
- Designed and produced all collateral materials, including brochures and fund-raising kit.
- Wrote speeches, remarks, and op-eds for Institute president; edited all written materials.
- Produced daily legal reform news digest, which was highly praised by Institute members.
- Served as spokesman for the Institute and pitched stories to the media.

MORTGAGE BANKERS ASSOCIATION, Washington, D.C. 2000 - 2001

➤ **Director of Media Relations and Spokesman**

- Wrote remarks, talking points, press releases, letters-to-the-editor on association's issues.
- Worked with national media and industry press to raise awareness of mortgage issues.
- Served as primary contact to media and spokesman for association.
- Produced daily html-based mortgage banking news digest. Highly praised by association leadership, members.

COASTAL CONSERVATION ASSOCIATION, Washington, D.C. 1999 - 2000

➤ **Director, Communications**

- Served as primary contact to media and spokesman for association.
- Wrote remarks, talking points, press releases, letters-to-the-editor on association issues.
- Worked with national media and industry press to raise awareness of organization's efforts.

U.S. CHAMBER OF COMMERCE, Washington, D.C. 1988 - 1999

➤ **Director, Corporate Communications**

- Helped launch Corporate Communications Division to better communicate organization's pro-business message to members, public, media, government officials.
- Wrote remarks, talking points, and op-eds for organization officials.
- Edited all written materials produced by Division.
- Wrote, edited, and produced monthly legislative membership magazine and annual report.
- Produced annual congressional vote-rating guide and biennial political endorsement report.

➤ **Senior Editor, *Nation's Business***

- Wrote articles on federal regulations, small business issues, labor law, education, and politics for monthly business magazines of U.S. Chamber of Commerce.
- Wrote, edited, and produced monthly four-color legislative magazine.
- Assigned topics to and edited articles by free-lance writers for legislative magazine.
- Attended congressional hearings, coalition meetings, and briefings on public-policy issues.
- Interviewed congressional lawmakers and staff, agency officials, and business people

NRA-INSTITUTE FOR LEGISLATIVE ACTION, Washington, D.C. 1984 - 1988

➤ **Editor and Spokesman**

- Wrote, edited, and produced monthly and bimonthly newspapers covering federal, state, and local gun control and hunting legislation for the then-3 million-member NRA.
- Wrote speeches for NRA executives; wrote press releases and editorial responses related to firearms. Editorials appeared in the *New York Times*, *The Washington Post*, *USA Today*, other newspapers.
- Served as primary spokesman for the association to the media on gun control issues.
- Tracked and analyzed federal, state, local gun control legislation and anti-hunting proposals.

EDUCATION

B.S., Mass Communication (Journalism and Public Relations); Minor, History. Towson State University, Towson, MD - 1982

Business, History, West Virginia University, Morgantown, WV

ORGANIZATIONS

Agricultural Relations Council

National Association of Farm Broadcasters

National Association of Agricultural Journalists



Office of City Clerk

**ANNOUNCEMENT FOR
BOARD VACANCIES**

Applications and letters of interest due to the City Clerk by Tuesday, August 8th :

- 1) **Planning Commission** – 1 vacancy

- 2) **Library Board** – 1 vacancy



11g



Date	May 17, 2023	Customer	Marine City	To	Jeff Schmidt
Description	WWTP and Lift Station Remote SCADA Viewing				mitrich@marinecity-mi.org
Quote #	230903				
Estimator	Duane Carr	Email	duane.carr@teamuis.com		

Scope of Work	Cost
----------------------	-------------

WWTP CRUiSE HMI for Remote SCADA Viewing

Furnish and install one (1) Micro Logix 1400 Gateway and cellular modem with antenna hardware to interface the existing WWTP PLC network with the CRUiSE HMI (cloud based).

Interface the existing SCADA computer with customer's Internet to allow access to the CRUiSE HMI.

Provide startup services.

Lift Station CRUiSE HMI for Remote SCADA Viewing

Furnish and install one (1) Allen Bradley Micro Logix 1400 PLC to upgrade the existing PLC that is no longer supported.

Furnish and install one cellular modem with antenna hardware to interface the new PLC with the CRUiSE HMI for remote viewing (no control).

Provide startup services.

CRUiSE HMI

Provide the first year of the CRUiSE (cloud-based HMI) subscription and cellular fees, currently \$1,760.00 per year. The CRUiSE provides easy trending, reports, unlimited MFA remote connections, and alarm notifications via voice calls, emails, and text messages.

Provide necessary startup and training services.

Total: \$22,325.00

UIS SCADA Approved by

Date May 17, 2023

Please make Purchase Orders/Subcontracts out to: UIS SCADA, Inc. and reference Quote #230903

Client Acceptance when the Client will not be providing a PO or Contract to UIS SCADA, Inc.

Client authorizes Utilities Instrumentation Service, Inc. to proceed with the work and agrees to comply with the attached Terms and Conditions.

Client Acceptance

Signature _____

Name _____

Title _____

Date _____

Exclusions and Clarifications

Pricing includes only the items listed above; anything not explicitly listed above is not included in our proposed scope of work.

Our quote is based on straight time during normal hours of 7:00 A.M. to 3:30 P.M., Monday through Friday, unless specified otherwise.

Team UIS
 2290 Bishop Circle East
 Dexter, MI 48130
 (734) 424-1200

Utilities Instrumentation Service
UIS SCADA
UIS Renewable Power
Utilities Instrumentation Service-Ohio

Our price is valid for thirty (30) days, after which time UIS SCADA, Inc. reserves the right to review and modify any and all portions of its proposal.

This proposal contains pricing and other information confidential and proprietary to UIS SCADA, Inc. and disclosure of the contents of this letter and any attachments to persons or organizations outside of this agreement is not authorized without specific written permission from UIS SCADA, Inc.

Team UIS - TERMS AND CONDITIONS

- 1. Offer.** These Terms and Conditions ("Terms") apply to all products and services, including without limitation, computer software program(s) and software as a service ("SaaS Services") provided to Client under an Order Confirmation with Utilities Instrumentation Services, Inc., Utilities Instrumentation Services – Ohio, LLC., UIS SCADA, Inc., and/or UIS Renewable Power, Inc., as applicable ("Team UIS"). These Terms are incorporated into each Order Confirmation issued by Team UIS to a Client of such products or services ("Client"). A confirmation or acknowledgement of an order ("Order Confirmation") will be issued to Client after the Client has submitted an order to Team UIS. The Order Confirmation constitutes Team UIS's offer to the Client identified in the Order Confirmation to sell the products and/or provide the services identified in the Order Confirmation ("Products" and "Services", respectively) and otherwise to enter into the agreement that the Order Confirmation and these Terms describe (the "Agreement"), and the Order Confirmation and these Terms shall be the complete and exclusive statement of such Agreement.
- 2. Acceptance.** A contract is formed when Client accepts the Order Confirmation by written acknowledgement, by accepting the Products and/or Services, or other issued acceptance documents for the Products and/or Services. Acceptance is expressly limited to the Agreement and shall not include any terms and conditions contained in Client's purchase order or similar document. Notwithstanding any contrary provision in Client's purchase order or other acceptance document or similar document, delivery of Products, performance of Services or commencement of Services by Team UIS shall not constitute acceptance of Client's terms and conditions to the extent any such terms or conditions are inconsistent with or in addition to the terms and conditions contained in the Agreement.
- 3. Prices.** Prices for Products and/or Services shall be set forth in the Order Confirmation. Unless otherwise expressly stated in the Order Confirmation: (a) prices for Products specified in the Order Confirmation do not include storage, handling, packaging, or transportation charges; and (b) prices do not include any applicable taxes.
- 4. Payment Terms.** Unless otherwise expressly stated in the Order Confirmation, all accounts are payable in U.S. currency thirty (30) days from the date of Team UIS's invoice. Credit and delivery of Products shall be subject to Team UIS's approval. The Client shall pay Team UIS for Services performed in accordance with the rates and charges set forth in the Order Confirmation. If the Client disputes any portion of an invoice, the Client shall notify Team UIS, in writing, within fourteen (14) calendar days of invoice receipt, identify the cause of the dispute, and pay when due any portion of the invoice not in dispute. Failure to provide such notification shall constitute acceptance of the invoice as submitted. If Client fails to pay undisputed invoiced amounts within the thirty (30) calendar days of the invoice date, Team UIS may at any time, without waiving any other claim against the Client (including lien rights) and without thereby incurring any liability to the Client, suspend or terminate the Order Confirmation. Client is prohibited from and shall not setoff against or recoup from any invoiced amounts due or to become due from Client or its affiliates any amounts due or to become due to Team UIS or its affiliates, whether arising under the Order Confirmation, any related purchase order or any other agreement.
- 5. Shipping and Delivery.** All sales of Products are F.O.B. Team UIS's plant unless otherwise specified in the Order Confirmation. Responsibility of Team UIS shall cease upon delivery to and receipt of the Products by a common carrier at which point Client will bear all risk of loss for the Products. Premium shipping expenses and/or other related expenses necessary to meet Client's accelerated delivery schedules shall be the responsibility of Client. Deliveries of orders placed by Client may be changed, deferred or canceled only upon specific agreement in writing by Team UIS and Team UIS may condition such agreement upon Client's assumption of liability and payment to Team UIS for: (a) a sum equal to the costs of work in process including costs accrued for labor and material; (b) any amount for which Team UIS is liable by reason of commitments made by Team UIS to its suppliers; and (c) any other loss, cost or expense of Team UIS as a result of such change, deferment or cancellation.
- 6. Proprietary Materials.** Team UIS shall have and retain all rights, title and interest, including all intellectual property rights, in and to all Products, Services and associated materials, including, without limitation, all related reports, specifications, designs and any other property, tangible or intangible (including software and SaaS Services), furnished by Team UIS in connection with or under the applicable Order Confirmation ("Proprietary Materials"). No Proprietary Materials created by Team UIS in connection with an Order Confirmation or any related purchase order shall be considered "works made for hire" as that term is used in connection with the U.S. Copyright Act.
- 7. Licenses.** Team UIS does not grant to Client any license with respect to the Products, and any such license terms with respect to the Products shall be governed solely by the licenses, if any, provided solely by the third-party manufacturers of such products.
- 8. SaaS Services. A.** Team UIS will provide Client with the SaaS Services, and allow Authorized Users to access the SaaS Services in connection with Client's use of the SaaS Services, as set forth in the applicable Order Confirmation. Prior to obtaining access to the SaaS Services, Client shall ensure that Authorized Users are registered in the SaaS Services with a unique User ID and a unique password. For purposes of this Agreement, "Authorized Users" means individuals who are authorized to use the SaaS Services pursuant to this Agreement or as otherwise defined, restricted or limited in an Order Confirmation, for whom subscriptions to SaaS Services have been procured, and who have been supplied user identifications and passwords by Client (or by Team UIS at Client's request). Authorized Users may include Clients' employees and Clients' agents and third-party contractors and their employees authorized by Client and/or approved by Team UIS to access the SaaS Services. **B.** Client is responsible for all activities conducted under its Authorized User logins and for its Authorized Users' compliance with this Agreement. Authorized Users may only use the SaaS Services during the term of the applicable Order Confirmation. **C.** Except as otherwise explicitly provided in this Agreement, Client and its Authorized Users will not, and will not permit third parties to: (a) use the SaaS Services except as expressly authorized in this Agreement; (b) access or use the SaaS Services to circumvent or exceed the applicable restrictions; (c) use any device, software, or routine that interferes or disrupts any application, function, or use of the SaaS Services; (d) copy, modify, translate, transmit, reproduce, distribute, republish, display, frame, or mirror the SaaS Services, except as permitted by this Agreement; (e) decompile, reverse-compile, disassemble, reverse-engineer or otherwise reduce to human-perceivable form all or any part of the SaaS Services or any part of the SaaS Services or otherwise attempt to discover any source code or create derivative works of the SaaS Services or any part of the SaaS Services; (f) rent, lease, resell, sublicense, or otherwise permit third parties to access or use the SaaS Services; (g) use the SaaS Services to provide services to third parties (e.g., as a service bureau or to otherwise provide data processing services to third parties); (h) circumvent or disable any security or other technological features or measures of any SaaS Services or any part of the SaaS Services; (i) use the SaaS Services to build a similar or competitive product or service; (j) create user accounts under false or fraudulent pretenses; (k) except as provided in an Order Confirmation, create shared or generic identifications and passwords to any SaaS Services; (l) use the SaaS Services in a manner that is contrary to applicable law or in violation of any third party rights of privacy or intellectual property rights; (m) use the SaaS Services to send or store viruses, worms, time bombs, trojan horses, or other harmful or malicious code, files, scripts, agents or programs; (n) access the SaaS Services for purposes of monitoring its availability, performance or functionality, or for any other benchmarking or competitive purposes; (o) remove, alter or obscure any of the intellectual property rights notice(s) or restrictive legend(s) embedded in or that Team UIS otherwise provides with the SaaS Services; (p) interfere with or disrupt the integrity or performance of the SaaS Services; or (q) obtain unauthorized access to the SaaS Services (including without limitation permitting access to or use of the SaaS Services via another system or tool, the primary effect of which is to enable input of requests or transactions by other than Authorized Users). **D.** Client shall at all times: (a) provide Team UIS with good faith cooperation and access to such information, facilities, and equipment as may be reasonably required by Team UIS in order to provide the SaaS Services, including, but not limited to, providing Client materials and security access, information, and software interfaces to Client's business applications; (b) provide such personnel assistance as may be reasonably requested by Team UIS from time to time; and (c) carry out in a timely manner all other Client responsibilities set forth in this Agreement. In the event of any delay in Client's performance of any of the obligations set forth in (a), (b) or (c), or any other delays caused by Client, Team UIS may adjust its performance as reasonably necessary to account for such delays.
- E.** Client is responsible for complying with any applicable laws relating to its or any Authorized User's use of the SaaS Services including, without limitation, all applicable privacy, electronic communications and data protection laws, rules, regulations, and regulatory guidelines, as well as any applicable self-regulatory guidelines. Without limiting the generality of the foregoing, Client is solely responsible for: (a) ensuring that Client and Team UIS, acting on Client's behalf, have the right to collect, use and share Client any personal data and related materials via the SaaS Services; and (b) providing adequate notice to, and obtaining any necessary consents as required under applicable laws, with respect to the Client materials and Client intellectual property collected, used and shared by Client, or by Team UIS on Client's behalf, via the SaaS Services. Notwithstanding any other provision of this Agreement, Client or any Authorized User shall not use the SaaS Services to collect, upload, retrieve, transmit, send, or store (i) any information that could directly identify a person, including, without limitation, government issued ID numbers, individual medical or health information (including protected health information under HIPAA), individual financial information, an individual's name (last name plus first name or first initial), or birth date; (ii) security codes, passwords, credit or debit card numbers; (iii) any data that falls under the sensitive or special data definitions of any applicable privacy law or self-regulatory principle; or (iv) any data collected from sites directed to children under the age of sixteen (16) or from children whose age Client knows to be under sixteen (16) in violation of applicable law. Team UIS and its designees shall have the right (but not the obligation) in their sole discretion to refuse or remove any Client materials or Client intellectual property that violate any of the terms of this Agreement or any applicable law. **F.** In connection with the operation of the SaaS Services, Team UIS may collect and analyze data in aggregate and anonymous form with respect to the use and effectiveness of the SaaS Services (the "Aggregate Data"). Client hereby irrevocably authorizes Team UIS to collect data in an aggregate and anonymous form for supporting, improving, and marketing the SaaS Services. Customer acknowledges and agrees that Team UIS will exclusively own all right, title, and interest in and to all Aggregate Data and other analytics and output data generated or provided by Team UIS or the SaaS Services. **G.** Client or Authorized Users providing any suggestions, enhancement requests, recommendations, corrections or other feedback (collectively, "Feedback") is strictly voluntary. If Client or any Authorized User provides any Feedback to Team UIS, orally or in writing, Client hereby grants to Team UIS and its affiliates a worldwide, perpetual, irrevocable, royalty-free license to use and incorporate into the SaaS Services any Feedback. **H.** Team UIS may immediately suspend the SaaS Services if Team UIS reasonably determines that the Client is not materially complying with this Agreement, or Client is using the SaaS Services in a manner that could cause damage to Team UIS's business or reputation, or otherwise reflect unfavorably upon Team UIS, its affiliates, or its partners. Team UIS shall notify the Client promptly following any such suspension taking effect.
- 9. Design.** Team UIS is not responsible for the design of the Products and will not, under any circumstances, have any warranty, indemnification or other liability or obligations with respect to Products to the extent related to or arising out of the design and/or specifications for such Products. Suggestions by Team UIS as to design, use and suitability of the Products are made in good faith; provided, however, Buyer assumes full responsibility for accepting and/or using such suggestions.

Team UIS
2290 Bend Circle East
Dexter, MI 48130
(734) 424-1200

Utilities Instrumentation Service
UIS SCADA
UIS Renewable Power
Utilities Instrumentation Service-Ohio

10. Warranty. (a) Team UIS warrants, that at the time of delivery, the Products will conform to the specifications, if any, that are a part of the Order Confirmation. Client understands and hereby expressly agrees that any claim for defective materials, defective manufacture, or any other claim with respect to the Products shall be made directly to the manufacturer of the Product and not the Team UIS. Team UIS makes no warranties, either express or implied, regarding defective materials, defective manufacture, or any other claim with respect to Products. Team UIS may, at its sole election, and as Client's sole remedy, make an allowance, repair, or replace such quantity of the Products as shall prove to be defective, then Client shall hold and make available for inspection and testing by Team UIS all Products claimed by Client to be defective. (b) Services provided by Team UIS under an Order Confirmation will be performed in a manner consistent with that degree of care and skill ordinarily exercised by members of the same profession currently practicing under similar circumstances. (c) THE TEAM UIS DISCLAIMS, AND CLIENT HEREBY EXPRESSLY WAIVES, ANY AND ALL OTHER WARRANTIES, WHETHER EXPRESS, IMPLIED OR STATUTORY, WITH RESPECT TO THE PRODUCTS AND/OR SERVICES, AND/OR THE RESULTS OBTAINED FROM THEIR USE BY CLIENT AND/OR ITS USERS, INCLUDING, WITHOUT LIMITATION, ANY STATUTORY OR IMPLIED WARRANTIES OF NON-INFRINGEMENT, MERCHANTABILITY OR FITNESS FOR A PARTICULAR PURPOSE. TEAM UIS HEREBY DISCLAIMS ANY AND ALL LIABILITY FOR THE USE OR PERFORMANCE OF THE SERVICES AND/OR PRODUCTS SELECTED BY THE PARTIES HEREBY EXPRESSLY ACKNOWLEDGE AND AGREE THAT THE UNIFORM COMMERCIAL CODE AND ANY SPECIFIC STATE ADOPTIONS THEREOF SHALL NOT GOVERN THE RIGHTS AND OBLIGATIONS OF THE PARTIES UNDER THESE TERMS OR ANY ORDER CONFIRMATION.

11. Liability Limitation. Specific performance shall not be available to Client as a remedy in connection with Team UIS's providing of the Products and/or Services. Monetary damages against Team UIS shall be limited to the dollar amount charged to Client for the applicable order placed by Client and accepted by Team UIS for any of the Services and/or Products alleged to be the cause of any loss or damage, whether founded in contract, tort (including negligence), strict liability or otherwise, arising out of, or resulting from any cause whatsoever, including without limitation: (a) any order placed by Client and accepted by Team UIS or Team UIS's performance or breach; or (b) the design, manufacture, delivery, sale, repair, replacement or use of any such Products. IN NO EVENT SHALL TEAM UIS BE LIABLE TO CLIENT FOR ANY SPECIAL, INDIRECT, EXEMPLARY, INCIDENTAL, PUNITIVE, OR CONSEQUENTIAL DAMAGES (INCLUDING, WITHOUT LIMITATION, LOSS OF ANTICIPATED PROFITS, LOSS OF USE, LOSS OF REVENUE AND COST OF CAPITAL) ARISING OUT OF OR RELATING TO THE AGREEMENT, INCLUDING WITHOUT LIMITATION THE ORDER CONFIRMATION, ANY RELATED PURCHASE ORDER, OR THE SERVICE AND/OR PRODUCTS. ANY AGREEMENT VARYING OR EXTENDING THE REMEDIES SPECIFICALLY STATED HEREIN WILL BE BINDING ON TEAM UIS ONLY WHEN SPECIFICALLY AGREED TO IN WRITING BY TEAM UIS AND SPECIFICALLY REFERENCING THIS SECTION.

12. Insurance. Team UIS has in effect commercial general liability, umbrella, cyber, workers compensation, employer's liability, and automobile insurance coverage. A certificate of insurance is available upon request. Customer shall have property and course of construction/builder's risk insurance for the full value of the site including any improvements made pursuant to this Contract and will provide Team UIS with proof of insurance upon request.

13. Termination. In the event that Client fails to perform any of its obligations stated in the Agreement, including the Order Confirmation or any related purchase order and fails to cure such breach within ten (10) days after receipt of written notice from the Team UIS specifying such breach, the Team UIS may at its option immediately terminate the Order Confirmation and/or any related purchase orders. Upon any such termination by Team UIS: (a) Team UIS shall be relieved of any further obligation to Client (including, without limitation, any obligation with respect to delivery or transition of supply); (b) Client shall be liable to Team UIS for the immediate payment of amounts then billed to date by Team UIS to Client; (c) Client shall purchase and pay Team UIS immediately for all raw materials, components, work in process and finished goods acquired by Team UIS in connection with the Order Confirmation and/or any related purchase orders; and (d) Client shall immediately reimburse Team UIS for all other loss, cost or expense of Team UIS as a result of the termination of the Order Confirmation or any related purchase order.

14. Right of Entry. If applicable, Client shall provide for Team UIS's right to enter the property owned by the Client and/or others in order for Team UIS to perform the Services in the Order Confirmation. The Client agrees, to the fullest extent permitted by law, to indemnify and hold Team UIS and his or her subconsultants harmless from any claim, liability or cost (including reasonable attorneys' fees and costs of defense) for injury or loss arising or allegedly arising from procedures associated with testing or investigative activities or discovery of hazardous materials or suspected hazardous materials on said property.

15. Force Majeure. Team UIS shall not be liable for any delay or failure to perform any obligation under this Agreement if such delay or failure is caused by circumstances beyond its reasonable control, including, without limitation, acts of God or public authority, riots or other public disturbances, labor disputes of any kind, electrical or power outages, utilities or telecommunications failures, earthquake, storms or other elements of nature, acts or orders of government, pandemics, acts of terrorism or war, or acts by third parties, failure of Client to provide required information, or the change in cost or availability of raw materials, components or services based on market conditions, supplier actions or contract disputes ("Force Majeure Event"). During a Force Majeure Event, Team UIS's obligations under the Order Confirmation and any related purchase order shall be suspended and Team UIS shall not have any obligation to provide Client with Products or Services from other sources or to pay or reimburse Client for any additional costs to Client of obtaining substitute Products or Services, nor shall Team UIS be liable for any damages to Client arising from or related to a Force Majeure Event.

16. Governing law. The contract shall be governed by the laws of Michigan

17. Employee Solicitation. Employee Solicitation. Client agrees not to hire, attempt to hire, or retain as consultants or otherwise, employees and/or consultants of Team UIS directly or through a third-party entity during the employment or consulting period and for a period of one (1) year subsequent to the employee's and/or consultant's last day of work for Team UIS regardless of the circumstances surrounding employee's cause of termination of employment.

18. Indemnification. Client holds harmless, indemnifies, and will defend Team UIS and its related or affiliated entities including their respective officers, agents and employees against any claims, liabilities, expenses, charges, fines and related losses including attorney's fees and expenses to the extent directly or indirectly caused by Client's (including those acting on behalf of Client) (a) negligent acts of omissions and involving property damage or bodily injury; (b) breach of the terms of the Agreement between the parties; or (c) violation of applicable law. This provision shall apply even if there is concurrent negligence but shall not apply to property damage or bodily injury arising solely from Team UIS's negligence. Liability per above is not limited by limits of workers compensation coverage.

19. Survival/Entire Agreement/Waiver/Applicable Laws. These Terms shall survive and continue in full force and effect following the expiration, cancellation or termination of an Order Confirmation and any related purchase order. The Order Confirmation, including these Terms and any other attachments, exhibits or supplements specifically referenced in the Order Confirmation, constitutes the entire agreement between Team UIS and Client with respect to the matters contained in the Order Confirmation and supersedes all prior oral or written representations and agreements. Except as otherwise provided in these Terms, the Order Confirmation may only be modified by a written agreement signed by Team UIS. Waiver by Team UIS of any of the terms or conditions of the Order Confirmation shall be effective only if in writing and signed by Team UIS, and shall not constitute a waiver of such terms as to any subsequent events or conditions, whether similar or dissimilar. No course of dealing or custom in the trade shall constitute a modification or waiver by Team UIS of any right. This Agreement is governed by the laws of the State of Michigan, except for its choice of laws provisions.

20. Electronic Signature. THE CONTRACT MAY BE SIGNED OR ACCEPTED ELECTRONICALLY, CONVEYING CUSTOMER'S ACCEPTANCE. COMPLIANCE WITH THE CONTRACT THROUGH ELECTRONIC MEANS INCLUDING, BUT NOT LIMITED TO, EMAIL ACKNOWLEDGEMENT, AND CUSTOMER'S ELECTRONIC SIGNATURE WILL BE DEEMED VALID AND BINDING. IF CUSTOMER CONTESTS THE VALIDITY OF THE CONTRACT BASED ON THE MEANS OF ELECTRONIC OR OTHER FORM OF EXECUTION OR ACCEPTANCE BY THE PARTIES AND THE CONTRACT IS HELD BY A COURT OR ARBITRATOR TO BE VALID, THE CUSTOMER SHALL PAY THE ATTORNEYS' FEES AND EXPENSES OF TEAM UIS ARISING FROM THE CUSTOMER'S CONTEST OF THE CONTRACT'S VALIDITY.

21. Escalation. Any material that has been quoted as a part of this project is calculated based upon current prices. The market for these materials is volatile, and sudden price increases could occur. Team UIS agrees to use its best efforts to obtain the lowest prices possible from our suppliers. However, should there be an increase in the price of materials that are purchased after the execution of contract Team UIS reserves the right to adjust the contract for the increase. Team UIS will provide timely written notice to the Client if this were to occur.

22. Postponement. In the event that the Client postpones the project, Team UIS reserves the right to charge the Client for costs incurred that will cause the project to exceed the original cost estimate. Team UIS will provide timely written notice to the Client if this were to occur.

23. Cancellation. In the event that the Client cancels the work once the work has been scheduled by Team UIS, Team UIS reserves the right to charge the Client as follows:

# of Days Prior to Scheduled Work	Cancellation Fee (% of Contract)
30	5.00%
15	7.50%
7	10.00%
3	15.00%

Thursday, March 9, 2023

Mike Itrich
City of Marine City
303 S Water St.
Marine City MI 48039-1694

Thank you for your interest in International trucks! As you are aware our industry continues to face unprecedented supply chain and production issues and this has impacted both our truck allocation and our ability to deliver ordered trucks in a timely manner. We deeply apologize for the inconvenience this has caused for your organization to schedule and budget for equipment purchases. At this time we are unable to accept PO s, deposits, or other forms of order securement until we receive additional information from our brand partner on the production outlook for 2024. We believe this information will be coming sometime soon in the second quarter of 2023. Until that time we will be able to continue to provide specs and tentative pricing on demand with the following qualifications:

- All specifications are subject to change prior to production based on our ability to source the requested components.
- All quoted pricing is subject to change prior to production based on internally published model year price guidelines, destination fees, and commodity or other surcharges which may change at any time.
- Your specification quote is not a slot or production promise to be built. We can take your info at this time to add to a list of interested parties. Once we have the ability to slot your order we will be in touch to re-confirm specs, pricing, and timing to solidify your intent to order.

Thank you again for your interest and if you have any questions feel free to reach me at any time.

TRI COUNTY INTL TRUCKS
JeremyKast

Prepared For:

City of Marine City
 Mike Itrich
 303 S Water St.
 Marine City, MI 48039-1694
 (810)765 - 1796
 Reference ID: MI Deal

Michigan MI Deal Quote

Presented By:

TRI COUNTY INTL TRUCKS
 Jeremy Kast
 3001 E HIGH ST
 JACKSON MI 49203
 (517)783-2721

Tri County International Trucks. Inc./State of Michigan DTMB Contract 071B6600122, Specification #3958 0160D-Option B for a new 2024 MY International Truck Chassis per this proposal. Pricing includes all user specified option equipment costs and available discounts in effect as of date listed. Please note that the afforded pricing includes a 1% fee paid to the state of Michigan as required under this contract. Additional surcharge requirements as issued by the manufacturer may be applicable in the future.

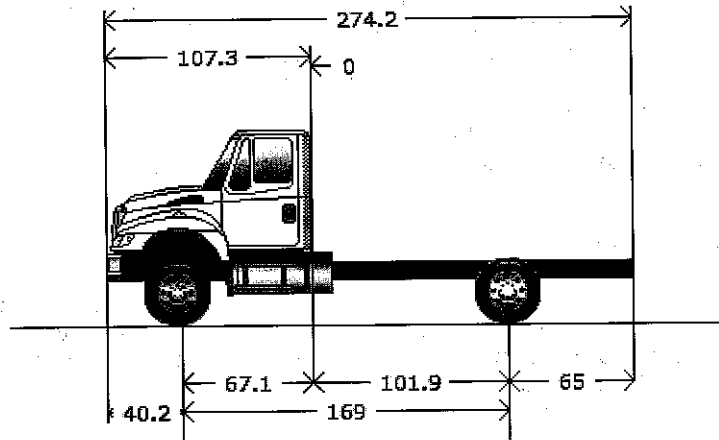

Model Profile
2024 HV607 SBA (HV607)

- AXLE CONFIG:** 4X2
- MISSION:** Requested GVWR: 36000. Calc. GVWR: 36220. Calc. GCWR: 80000
 Calc. Start / Grade Ability: 44.72% / 3.18% @ 55 MPH
 Calc. Geared Speed: 67.4 MPH
- DIMENSION:** Wheelbase: 169.00, CA: 101.90, Axle to Frame: 65.00
- ENGINE, DIESEL:** {Cummins L9 300} EPA 2021, 300HP @ 2200 RPM, 860 lb-ft Torque @ 1200 RPM, 2200 RPM Governed Speed, 300 Peak HP (Max)
- TRANSMISSION, AUTOMATIC:** {Allison 3500 RDS} 6th Generation Controls, Wide Ratio, 6-Speed with Double Overdrive, with PTO Provision, Less Retarder, Includes Oil Level Sensor, with 80,000-lb GVW and GCW Max, On/Off Highway
- CLUTCH:** Omit Item (Clutch & Control)
- AXLE, FRONT NON-DRIVING:** {Meritor MFS-14-143A} Wide Track, I-Beam Type, 14,000-lb Capacity
- AXLE, REAR, SINGLE:** {Meritor RS-23-160} Single Reduction, 23,000-lb Capacity, Driver Controlled Locking Differential, 200 Wheel Ends Gear Ratio: 6.14
- CAB:** Conventional, Day Cab
- TIRE, FRONT:** (2) 11R22.5 Load Range H HSR 3 (CONTINENTAL), 494 rev/mile, 75 MPH, All-Position
- TIRE, REAR:** (4) 11R22.5 Load Range H HDR2+ (CONTINENTAL), 491 rev/mile, 75 MPH, Drive
- SUSPENSION, REAR, SINGLE:** 23,500-lb Capacity, Vari-Rate Springs, with 4500-lb Capacity Auxiliary Rubber Springs
- PAINT:** Cab schematic 100WL
 Location 1: 9219, Winter White (Std)
 Chassis schematic N/A

<u>Code</u>	<u>Description</u>	<u>F/R Wt</u> (lbs)	<u>Tot Wt</u> (lbs)
HV60700	Base Chassis, Model HV607 SBA with 169.00 Wheelbase, 101.90 CA, and 65.00 Axle to Frame.	6136/3644	9780
1570	TOW HOOK, FRONT (2) Frame Mounted	8/0	8
1572	TOW HOOK, REAR (2)	0/10	10
1ANA	AXLE CONFIGURATION {Navistar} 4x2	-29/-106	-135
	<u>Notes</u> : Pricing may change if axle configuration is changed.		
1CAJ	FRAME RAILS Heat Treated Alloy Steel (120,000 PSI Yield); 10.866" x 3.622" x 0.437" (276.0mm x 92.0mm x 11.1mm); 456.0" (11582mm) Maximum OAL	124/332	456
1LNR	BUMPER, FRONT Swept Back, Steel, Painted 0001 Canyon Black, Heavy Duty	0/0	0
1WGR	WHEELBASE RANGE 138" (350cm) Through and Including 187" (475cm)	74/-74	0
2ARV	AXLE, FRONT NON-DRIVING {Meritor MFS-14-143A} Wide Track, I-Beam Type, 14,000-lb Capacity	60/0	60
3ADD	SUSPENSION, FRONT, SPRING Parabolic Taper Leaf, Shackle Type, 14,000-lb Capacity, with Shock Absorbers	44/0	44
4091	BRAKE SYSTEM, AIR Dual System for Straight Truck Applications	0/0	0
	<u>Includes</u> : BRAKE LINES Color and Size Coded Nylon : DRAIN VALVE Twist-Type : GAUGE, AIR PRESSURE (2) Air 1 and Air 2 Gauges; Located in Instrument Cluster : PARKING BRAKE CONTROL Yellow Knob, Located on Instrument Panel : PARKING BRAKE VALVE For Truck : QUICK RELEASE VALVE On Rear Axle for Spring Brake Release: 1 for 4x2, 2 for 6x4 : SPRING BRAKE MODULATOR VALVE R-7 for 4x2, SR-7 with relay valve for 6x4/8x6		
4619	TRAILER CONNECTIONS Four-Wheel, with Hand Control Valve and Tractor Protection Valve, for Straight Truck	2/0	2
	<u>Notes</u> : When electronic stability control is ordered with trailer connections on a 4x2 truck, please check the operator manual for trailer weight restrictions.		
4732	DRAIN VALVE {Berg} with Pull Chain, for Air Tank	0/0	0
4AZA	AIR BRAKE ABS {Bendix AntiLock Brake System} 4-Channel (4 Sensor/4 Modulator) Full Vehicle Wheel Control System	0/0	0
4EBD	AIR DRYER {Wabco System Saver 1200} with Heater	7/4	11
4EXP	BRAKE CHAMBERS, FRONT AXLE {Bendix} 20 SqIn	2/0	2
4EXU	BRAKE CHAMBERS, REAR AXLE {Bendix EverSure} 30/30 SqIn Spring Brake	0/7	7
4GBM	BRAKE, PARKING Manual Push-Pull Pneumatic Parking Brake	1/0	1
4LAG	SLACK ADJUSTERS, FRONT {Gunite} Automatic	14/0	14

<u>Code</u>	<u>Description</u>	<u>F/R Wt Tot Wt</u>	
		(lbs)	(lbs)
4LGG	SLACK ADJUSTERS, REAR {Gunite} Automatic	0/14	14
4LGR	SLACK ADJUSTER PINS Stainless Steel Slack Adjuster Pins/Cotter Pins on Front and Rear	0/0	0
4SPA	AIR COMPRESSOR {Cummins} 18.7 CFM	0/0	0
4VCL	AIR TANK LOCATION (2) Mounted 25" Back of Cab, Outside Right Rail, with Ground Clearance	0/40	40
4VKC	AIR DRYER LOCATION Mounted Inside Left Rail, Back of Cab	13/8	21
4XDP	BRAKES, FRONT {Meritor 16.5X5 Q-PLUS CAST} Air S-Cam Type, Cast Spider, Fabricated Shoe, Double Anchor Pin, Size 16.5" X 5", 14,700-lb Capacity	-23/0	-23
4XDR	BRAKES, REAR {Meritor 16.5X7 Q-PLUS CAST} Air S-Cam Type, Cast Spider, Fabricated Shoe, Double Anchor Pin, Size 16.5" X 7", 23,000-lb Capacity per Axle	0/52	52
5708	STEERING COLUMN Tilting	14/1	15
5CAW	STEERING WHEEL 4-Spoke; 18" Dia., Black	0/0	0
5PSA	STEERING GEAR {Sheppard M100} Power	0/0	0
6DGG	DRIVELINE SYSTEM {Dana Spicer} 1710, for 4x2/6x2	6/22	28
7BEV	AFTERTREATMENT COVER Steel, Black	10/3	13
7BMB	EXHAUST SYSTEM Horizontal Aftertreatment System, Frame Mounted Right Side Under Cab, for Single Vertical Tail Pipe, Frame Mounted Right Side Back of Cab, for Improved Ground Clearance	127/38	165
7WAY	TAIL PIPE (1) Straight Type, Bright	5/4	9
7WDM	EXHAUST HEIGHT 10'	16/12	28
7WDN	MUFFLER/TAIL PIPE GUARD (1) Aluminum	9/7	16
8000	ELECTRICAL SYSTEM 12-Volt, Standard Equipment	0/0	0
	<u>Includes</u>		
	: DATA LINK CONNECTOR For Vehicle Programming and Diagnostics In Cab		
	: HAZARD SWITCH Push On/Push Off, Located on Instrument Panel to Right of Steering Wheel		
	: HEADLIGHT DIMMER SWITCH Integral with Turn Signal Lever		
	: PARKING LIGHT Integral with Front Turn Signal and Rear Tail Light		
	: STARTER SWITCH Electric, Key Operated		
	: STOP, TURN, TAIL & B/U LIGHTS Dual, Rear, Combination with Reflector		
	: TURN SIGNAL SWITCH Self-Cancelling for Trucks, Manual Cancelling for Tractors, with Lane Change Feature		
	: WINDSHIELD WIPER SWITCH 2-Speed with Wash and Intermittent Feature (5 Pre-Set Delays), Integral with Turn Signal Lever		
	: WINDSHIELD WIPERS Single Motor, Electric, Cowl Mounted		
	: WIRING, CHASSIS Color Coded and Continuously Numbered		
8518	CIGAR LIGHTER Includes Ash Cup	1/0	1
8541	HORN, ELECTRIC (2) Disc Style	1/0	1
8695	SNOW SHIELD (2) Chrome; for Dual Air Horns	2/0	2

Code	Description	F/R Wt (lbs)	Tot Wt (lbs)
8GXJ	ALTERNATOR {Leece-Neville AVI160P2013} Brush Type, 12 Volt, 160 Amp Capacity, Pad Mount	0/0	0
8HAB	BODY BUILDER WIRING Back of Day Cab at Left Frame or Under Sleeper, Extended or Crew Cab at Left Frame; Includes Sealed Connectors for Tail/Amber Turn/Marker/ Backup/Accessory Power/Ground and Sealed Connector for Stop/Turn	2/0	2
8HAH	ELECTRIC TRAILER BRAKE/LIGHTS Accommodation Package to Rear of Frame; for Combined Trailer Stop, Tail, Turn, Marker Light Circuits; Includes Electric Trailer Brake Accommodation Package with Cab Connections for Mounting Customer Installed Electric Brake Unit, Less Trailer Socket	0/2	2
8HXT	HORN, AIR (2) Single Tone, Chrome, Roof Mounted, with Lanyard Pull Cord	0/0	0
8MSG	BATTERY SYSTEM {Fleetrite} Maintenance-Free, (3) 12-Volt 1980CCA Total, Top Threaded Stud	25/28	53
8RGA	2-WAY RADIO Wiring Effects; Wiring with 20 Amp Fuse Protection, Includes Ignition Wire with 5 Amp Fuse, Wire Ends Heat Shrink and Routed to Center of Header Console in Cab	1/0	1
8RMH	BATTERY DISCONNECT SWITCH {Cole-Hersee 75920-06} 300 Amp, Disconnects Charging Circuits, Locks with Padlock, Battery Box Mounted	3/0	3
8RMV	SPEAKERS (2) 6.5" Dual Cone Mounted in Doors	5/0	5
8RPR	ANTENNA for Increased Roof Clearance Applications	1/0	1
8RPS	RADIO AM/FM/WB/Clock/Bluetooth/USB Input/Auxiliary Input	3/0	3
8TKK	TRAILER AUXILIARY FEED CIRCUIT for Electric Trailer Brake Accommodation/Air Trailer ABS; with 30 Amp Fuse and Relay, Controlled by Ignition Switch	1/0	1
8VUL	BATTERY BOX Steel, with Plastic Cover, 18" Wide, 2-4 Battery Capacity, Mounted Left Side Back of Cab	-36/13	-23
8WBW	JUMP START STUD Remote Mounted	2/0	2
8WGL	WINDSHIELD WIPER SPD CONTROL Force Wipers to Slowest Intermittent Speed When Park Brake Set and Wipers Left on for a Predetermined Time	0/0	0
8WPH	CLEARANCE/MARKER LIGHTS (5) {Truck Lite} Amber LED Lights, Flush Mounted on Cab or Sunshade	0/0	0
8WPZ	TEST EXTERIOR LIGHTS Pre-Trip Inspection will Cycle all Exterior Lamps Except Back-up Lights	0/0	0
8WRB	HEADLIGHTS ON W/WIPERS Headlights Will Automatically Turn on if Windshield Wipers are turned on	0/0	0
8WTP	COURTESY LIGHT (2) Mounted In Front Map Pocket Left and Right Side	1/0	1
8WWJ	INDICATOR, LOW COOLANT LEVEL with Audible Alarm	0/0	0
8WXB	HEADLIGHT WARNING BUZZER Sounds When Head Light Switch is on and Ignition Switch is in "Off" Position	0/0	0

<u>Code</u>	<u>Description</u>	<u>F/R Wt Tot Wt</u>	
		(lbs)	(lbs)
8WXD	ALARM, PARKING BRAKE Electric Horn Sounds in Repetitive Manner When Vehicle Park Brake is "NOT" Set, with Ignition "OFF" and any Door Opened	0/0	0
8WXG	STARTING MOTOR {Mitsubishi Electric Automotive America 105P} 12-Volt, with Soft-Start	10/0	10
8WZP	INDICATOR, BATTERY WARNING Green BATTERY ON Indicator, Mounted on Left Side of Instrument Panel, To be Used with Factory Installed or Customer Mounted Battery Disconnect Switch	1/0	1
8XAH	CIRCUIT BREAKERS Manual-Reset (Main Panel) SAE Type III with Trip Indicators, Replaces All Fuses	0/0	0
8XGT	TURN SIGNALS, FRONT Includes LED Side Turn Lights Mounted on Fender	0/0	0
8XHR	POWER SOURCE, ADDITIONAL Auxiliary Power Outlet (APO) with USB Port, Located in the Instrument Panel	1/0	1
8XNY	HEADLIGHTS Halogen	0/0	0
9585	FENDER EXTENSIONS Rubber	6/0	6
9AAB	LOGOS EXTERIOR Model Badges	0/0	0
9AAE	LOGOS EXTERIOR, ENGINE Badges	0/0	0
9HAN	INSULATION, UNDER HOOD for Sound Abatement	10/0	10
9HBM	GRILLE Stationary, Chrome	0/0	0
9HBN	INSULATION, SPLASH PANELS for Sound Abatement	2/0	2
9WAC	BUG SCREEN Mounted Behind Grille	5/0	5
9WBC	FRONT END Tilting, Fiberglass, with Three Piece Construction, for WorkStar/HV	0/0	0
10060	PAINT SCHEMATIC, PT-1 Single Color, Design 100	0/0	0
	<u>Includes</u> : PAINT SCHEMATIC ID LETTERS "WL"		
10761	PAINT TYPE Base Coat/Clear Coat, 1-2 Tone	0/0	0
10AGB	COMMUNICATIONS MODULE Telematics Device with Over the Air Programming; Includes Five Year Data Plan and International 360	1/0	1
10SLV	PROMOTIONAL PACKAGE Government Silver Package	0/0	0
10WCY	SAFETY TRIANGLES	6/0	6
11001	CLUTCH Omit Item (Clutch & Control)	0/0	0
12703	ANTI-FREEZE Red, Extended Life Coolant; To -40 Degrees F/ -40 Degrees C, Freeze Protection	0/0	0
12849	BLOCK HEATER, ENGINE 120V/1000W, for Cummins ISB/B6.7/ISL/L9 Engines	3/0	3
	<u>Includes</u> : BLOCK HEATER SOCKET Receptacle Type; Mounted below Drivers Door		
12851	PTO EFFECTS, ENGINE FRONT Less PTO Unit, Includes Adapter Plate on Engine Front Mounted	10/0	10

<u>Code</u>	<u>Description</u>	<u>F/R Wt</u>	<u>Tot Wt</u>
		(lbs)	(lbs)
12ESL	ENGINE, DIESEL {Cummins L9 300} EPA 2021, 300HP @ 2200 RPM, 860 lb-ft Torque @ 1200 RPM, 2200 RPM Governed Speed, 300 Peak HP (Max)	585/-21	564
12THT	FAN DRIVE {Horton Drivemaster} Two-Speed Type, Direct Drive, with Residual Torque Device for Disengaged Fan Speed <u>Includes</u> : FAN Nylon	0/0	0
12UWZ	RADIATOR Aluminum, Cross Flow, Front to Back System, 1228 SqIn, with 1167 SqIn Charge Air Cooler, Includes In-Tank Oil Cooler <u>Includes</u> : DEAERATION SYSTEM with Surge Tank : HOSE CLAMPS, RADIATOR HOSES Gates Shrink Band Type; Thermoplastic Coolant Hose Clamps : RADIATOR HOSES Premium, Rubber	23/-5	18
12VBB	AIR CLEANER Dual Element	4/0	4
12VJH	EMISSION, CALENDAR YEAR {Cummins L9} EPA, OBD and GHG Certified for Calendar Year 2023	0/0	0
12VXT	THROTTLE, HAND CONTROL Engine Speed Control; Electronic, Stationary, Variable Speed; Mounted on Steering Wheel	0/0	0
12VYP	ENGINE CONTROL, REMOTE MOUNTED No Provision for Remote Mounted Engine Control	0/0	0
12WBR	FAN OVERRIDE Manual; with Electric Switch on Instrument Panel, (Fan On with Switch On)	0/0	0
12WZE	CARB IDLE COMPLIANCE Federal, Does Not Comply with California Clean Air Idle Regulations	0/0	0
12XCS	CARB EMISSION WARR COMPLIANCE Federal, Does Not Comply with CARB Emission Warranty	0/0	0
13BDR	TRANSMISSION, AUTOMATIC {Allison 3500 RDS} 6th Generation Controls, Wide Ratio, 6-Speed with Double Overdrive, with PTO Provision, Less Retarder, Includes Oil Level Sensor, with 80,000-lb GVW and GCW Max, On/Off Highway	216/67	283
13WET	TRANSMISSION SHIFT CONTROL Column Mounted Stalk Shifter, Not for Use with Allison 1000 & 2000 Series Transmission	1/0	1
13WLP	TRANSMISSION OIL Synthetic; 29 thru 42 Pints	0/0	0
13WUC	ALLISON SPARE INPUT/OUTPUT for Rugged Duty Series (RDS) and Regional Haul Series (RHS), General Purpose Trucks, Construction, Package Number 223	0/0	0
13WVV	NEUTRAL AT STOP Allison Transmission Shifts to Neutral When Service Brake is Depressed and Vehicle is at Stop; Remains in Neutral Until Service Brake is Released	0/0	0
13WYH	TRANSMISSION TCM LOCATION Located Inside Cab	0/0	0
13WYU	SHIFT CONTROL PARAMETERS {Allison} 3000 or 4000 Series Transmissions, Performance Programming	0/0	0
13XAM	PTO LOCATION Dual, Customer Intends to Install PTO at Left and/or Right Side of Transmission	0/0	0

<u>Code</u>	<u>Description</u>	<u>F/R</u>	<u>Wt</u>	<u>Tot</u>	<u>Wt</u>
		(lbs)	(lbs)		(lbs)
14ARB	AXLE, REAR, SINGLE {Meritor RS-23-160} Single Reduction, 23,000-lb Capacity, Driver Controlled Locking Differential, 200 Wheel Ends . Gear Ratio: 6.14	0/218			218
14VAH	SUSPENSION, REAR, SINGLE 23,500-lb Capacity, Vari-Rate Springs, with 4500-lb Capacity Auxiliary Rubber Springs	0/62			62
14WMG	AXLE, REAR, LUBE {EmGard FE-75W-90} Synthetic Oil; 30 thru 39.99 Pints	0/0			0
15LNR	FUEL/WATER SEPARATOR {Racor 400 Series} with Primer Pump, Includes Water-in-Fuel Sensor, Mounted on Engine	0/0			0
15SGJ	FUEL TANK Top Draw, Non-Polished Aluminum, D-Style, 16" Tank Depth, 50 US Gal (189L), Mounted Left Side, Under Cab	23/3			26
15WDG	DEF TANK 7 US Gal (26L) Capacity, Frame Mounted Outside Left Rail, Under Cab	0/0			0
16030	CAB Conventional, Day Cab	0/0			0
16BAM	AIR CONDITIONER with Integral Heater and Defroster	0/0			0
16GED	GAUGE CLUSTER Base Level; English with English Electronic Speedometer	0/0			0
	<u>Includes</u>				
	: GAUGE CLUSTER DISPLAY: Base Level (3" Monochromatic Display), Premium Level (5" LCD Color Display); Odometer, Voltmeter, Diagnostic Messages, Gear Indicator, Trip Odometer, Total Engine Hours, Trip Hours, MPG, Distance to Empty/Refill for				
	: GAUGE CLUSTER Speedometer, Tachometer, Engine Coolant Temp, Fuel Gauge, DEF Gauge, Oil Pressure Gauge, Primary and Secondary Air Pressure				
	: WARNING SYSTEM Low Fuel, Low DEF, Low Oil Pressure, High Engine Coolant Temp, Low Battery Voltage (Visual and Audible), Low Air Pressure (Primary and Secondary)				
16GHU	GRAB HANDLE, CAB INTERIOR (2) Safety Yellow	0/0			0
16HGH	GAUGE, OIL TEMP, AUTO TRANS for Allison Transmission	1/0			1
16HHE	GAUGE, AIR CLEANER RESTRICTION {Filter-Minder} with Black Bezel, Mounted in Instrument Panel	2/0			2
16HKT	IP CLUSTER DISPLAY On Board Diagnostics Display of Fault Codes in Gauge Cluster	0/0			0
16JNT	SEAT, DRIVER {National 2000} Air Suspension, High Back with Integral Headrest, Vinyl, Isolator, 1 Chamber Lumbar, with 2 Position Front Cushion Adjust, -3 to +14 Degree Angle Back Adjust	0/0			0
16LUM	SEAT, PASSENGER {National} Non Suspension, High Back with Integral Headrest, Vinyl, with Fixed Back, with Under Seat Storage	34/14			48
16SEE	GRAB HANDLE, EXTERIOR Chrome, Towel Bar Type, with Anti-Slip Rubber Inserts, for Cab Entry Mounted Left Side at B-Pillar	3/0			3
16SNP	MIRRORS (2) C-Loop, Power Adjust, Heated, Black Heads and Arms, 7.5" x 14" Flat Glass, Includes 7.5" x 7" Convex Mirrors, for 102" Load Width	0/0			0

Notes

<u>Code</u>	<u>Description</u>	<u>F/R Wt</u> (lbs)	<u>Tot Wt</u> (lbs)
	: Mirror Dimensions are Rounded to the Nearest 0.5"		
16VCC	SEAT BELT All Orange; 1 to 3	0/0	0
16VKB	CAB INTERIOR TRIM Classic, for Day Cab	0/0	0
	<u>Includes</u> : CONSOLE, OVERHEAD Molded Plastic with Dual Storage Pockets, Retainer Nets and CB Radio Pocket; Located Above Driver and Passenger : DOME LIGHT, CAB Door Activated and Push On-Off at Light Lens, Timed Theater Dimming, Integral to Overhead Console, Center Mounted : SUN VISOR (2) Padded Vinyl; 2 Moveable (Front-to-Side) Primary Visors, Driver Side with Toll Ticket Strap		
16VLV	MONITOR, TIRE PRESSURE Omit	-10/-1	-11
16WBY	ARM REST, RIGHT, DRIVER SEAT	3/0	3
16WEE	CAB SOUND INSULATION Includes Dash Insulator and Engine Cover Insulator	12/0	12
16WJU	WINDOW, POWER (2) and Power Door Locks, Left and Right Doors, Includes Express Down Feature	0/0	0
16WLS	FRESH AIR FILTER Attached to Air Intake Cover on Cowl Tray in Front of Windshield Under Hood	0/0	0
16WSK	CAB REAR SUSPENSION Air Bag Type	0/0	0
16XCW	CAB, INTERIOR TRIM, CLOSEOUT Under IP, Driver Side	0/0	0
16XJN	INSTRUMENT PANEL Flat Panel	0/0	0
16ZBT	ACCESS, CAB Steel, Driver & Passenger Sides, Two Steps per Door, for use with Day Cab and Extended Cab	0/0	0
27DJM	WHEELS, FRONT {Maxion 91541} DISC; 22.5x8.25 Rims, Painted Steel, 2-Hand Hole, 10-Stud, 285.75mm BC, Hub-Piloted, Flanged Nut, with Steel Hubs	-12/0	-12
28DJM	WHEELS, REAR {Maxion 91541} DUAL DISC; 22.5x8.25 Rims, Painted Steel, 2-Hand Hole, 10-Stud, 285.75mm BC, Hub-Piloted, Flanged Nut, with Steel Hubs	0/-24	-24
29PAR	PAINT IDENTITY, FRONT WHEELS Disc Front Wheels; with Vendor Applied White Powder Coat Paint	0/0	0
29PAS	PAINT IDENTITY, REAR WHEELS Disc Rear Wheels; with Vendor Applied White Powder Coat Paint	0/0	0
60AAG	BDY INTG, REMOTE POWER MODULE Mounted Inside Cab Behind Driver Seat, Up to 6 Outputs & 6 Inputs, Max 20 amp per Channel, Max 80 amp Total; Includes 1 Switch Pack with Latched Switches	0/0	0
60AJK	BDY INTG, INDICATOR LIGHTS (2) 1 for Body Up, 1 for Gate Open, Includes Audible Alarm, Programmable Mode for Various Switch Actions. (Requires 2 Remote Power Module Inputs)	0/0	0
7382135439	(2) TIRE, FRONT 11R22.5 Load Range H HSR 3 (CONTINENTAL), 494 rev/mile, 75 MPH, All-Position	4/0	4
7382135444	(4) TIRE, REAR 11R22.5 Load Range H HDR2+ (CONTINENTAL), 491 rev/mile, 75 MPH, Drive	0/20	20

<u>Code</u>	<u>Description</u>	<u>F/R Wt</u>	<u>Tot Wt</u>
		(lbs)	(lbs)
	Cab schematic 100WL		
	Location 1: 9219, Winter White (Std)		
	Chassis schematic N/A		
	Services Section:		
40128	WARRANTY Standard for HV507, HV50B, HV607 Models, Effective with Vehicles Built July 1, 2017 or Later, CTS-2025A	0/0	0
	Total Component Weight:	7576/4394	11970
		(lbs)	(lbs)
		(lbs)	(lbs)
	Mi Deal Fee Spec 3958-0160D Option B	0/0	0
	Commodity Surcharge	0/0	0
	Total Goods Purchased:	0/0	0

The weight calculations included in this proposal are an estimate of future vehicle weight. The actual weight as manufactured may be different from the estimated weight. Navistar, Inc. shall not be liable for any consequences resulting from any differences between the estimated weight of a vehicle and the actual weight.

(0012ESL)

ATTACHMENTS: 0012VXT 0012THT

<u>Parameter</u>	<u>Value</u>	<u>UOM</u>
Max Accelerator Vehicle Speed	67	MPH
Road Speed Governor Upper Droop	3	MPH
Road Speed Governor Lower Droop	0	MPH
Driver Initiated Override (DIO)	N, DISABLE FEATURE OR FUNCTION	N/A
DIO Maximum Road Speed Delta	3	MPH
DIO Maximum Distance	100	MILES
Max Engine Speed No Veh Speed Sensr	2184	RPM
LBSC Enable	N, DISABLE FEATURE OR FUNCTION	N/A
LBSC - Engine Speed Breakpoint	1800	RPM
Fuel Economy Adjustment Factor	4, MAXIMUM FUEL ECONOMY	N/A
Gear Down Protection Enable	N, DISABLE FEATURE OR FUNCTION	N/A
GDP - Heavy Load Vehicle Speed	62	MPH
GDP - Light Load Vehicle Speed	57	MPH
Driver Reward Enable	N, DISABLE FEATURE OR FUNCTION	N/A
Driver Reward Mode	0, ROAD SPEED GOVERNOR	N/A
Fuel Economy - Expected Level	7.00	MPG
Fuel Economy - Good Level	7.25	MPG
Fuel Economy - Best Level	7.50	MPG
% Idle Time - Expected Level	30	%
% Idle Time - Good Level	20	%
% Idle Time - Best Level	10	%
Speed Reward - Expected Level	0	MPH
Speed Reward - Good Level	0	MPH
Speed Reward - Best Level	0	MPH
Speed Reward - Penalty Level	0	MPH
Idle Speed Adjustment Enable	Y, ENABLE FEATURE OR FUNCTION	N/A
Low Idle Speed	750	RPM
Idle Shutdown Enable	N, DISABLE FEATURE OR FUNCTION	N/A
ISD Time Before Shutdown	15.0	MIN
ISD Percent Engine Loading	100	%
ISD In PTO	N, DISABLE FEATURE OR FUNCTION	N/A
ISD Manual Override	N, DISABLE FEATURE OR FUNCTION	N/A
ISD With Parking Brake Set	N, DISABLE FEATURE OR FUNCTION	N/A
ISD Ambient Temperature Override	N, DISABLE FEATURE OR FUNCTION	N/A
ISD Cold Ambient Air Temperature	30	F
ISD Intermediate Ambient Air Temp	40	F
ISD Hot Ambient Air Temperature	81	F
ISD Manual Override Inhibit Zone En	N, DISABLE FEATURE OR FUNCTION	N/A
ISD Hot Ambient Automatic Override	Y	N/A
ISD Engine Coolant Temp Threshold	53	F
Cruise Control Enable	Y, ENABLE FEATURE OR FUNCTION	N/A
CC Maximum Vehicle Speed	67	MPH
CC Save Set Speed	N, DISABLE FEATURE OR FUNCTION	N/A
CC Upper Droop	3.0	MPH
CC Lower Droop	0.0	MPH
CC Auto Resume	N, DISABLE FEATURE OR FUNCTION	N/A
CC Engine Brake Swtch Bypass Enable	N, DISABLE FEATURE OR FUNCTION	N/A
Engine Fan Min On Time For AC	30	SEC
Remote Accelerator Enable	N, DISABLE FEATURE OR FUNCTION	N/A
Remote Accelerator Mode	1, REMOTE ACCELERATOR PEDAL OR LEVER WITH TRANS VERIFICATION	N/A
PTO Enable	Y, ENABLE FEATURE OR FUNCTION	N/A
PTO In Cab Mode	Y, ENABLE FEATURE OR FUNCTION	N/A
Remote PTO Enable	N, DISABLE FEATURE OR FUNCTION	N/A
Remote Station PTO Enable	N, DISABLE FEATURE OR FUNCTION	N/A

PTO Max Engine Speed	2200	RPM
PTO Min Engine Speed	750	RPM
PTO Maximum Engine Load	800	LB-FT
PTO Max Vehicle Speed	2	MPH
PTO Accelerator Override	N, DISABLE FEATURE OR FUNCTION	N/A
PTO Accel Override Max Engine Speed	2400	RPM
PTO Clutch Override	N, DISABLE FEATURE OR FUNCTION	N/A
PTO Service Brake Override	Y, ENABLE FEATURE OR FUNCTION	N/A
PTO Parking Brake Interlock Mode	1, PTO PRK BRK INT TYPE SET TO CAB ONLY	N/A
PTO Transmission Neutral Interlock	Y, ENABLE FEATURE OR FUNCTION	N/A
PTO Eng Spd Limit w/VSS Limit	N, DISABLE FEATURE OR FUNCTION	N/A
PTO Ignore Vehicle Speed Sensor	N, DISABLE FEATURE OR FUNCTION	N/A
PTO Resume Switch Speed	925	RPM
PTO Set Switch Speed	850	RPM
PTO Additional Switch Speed	950	RPM
PTO Ramp Rate	250	RPM/SEC
Remote PTO Number of Speed Settings	1	N/A
Remote PTO Speed Setting 1	1000	RPM
Remote PTO Speed Setting 2	1200	RPM
Remote PTO Speed Setting 3	1400	RPM
Remote PTO Speed Setting 4	1400	RPM
Remote PTO Speed Setting 5	1500	RPM
Remote Station PTO Resume Sw Spd	1000	RPM
Remote Station PTO Set Switch Speed	1500	RPM
Remote Station PTO Addition Sw Spd	1500	RPM
Transmission Driven PTO	N, DISABLE FEATURE OR FUNCTION	N/A
Transmission Driven PTO Type	0, ENGINE DRIVEN STEADY LOAD	N/A
Powertrain Protection Enable	N, DISABLE FEATURE OR FUNCTION	N/A
Max Torque Allow By Axle/Driveshaft	23602	LB-FT
Max Torque in Top Gear Range	2995	LB-FT
Max Torque in Int. Gear Range	2995	LB-FT
Max Torque in Low Gear Range	2995	LB-FT
Max Torque w/o Vehicle Speed	1475	LB-FT
Lowest Gear of Top Gear Range	2.00	N/A
Lowest Gear of Int. Gear Range	3.00	N/A
Lowest Gear of Low Gear Range	6.00	N/A
Engine Protection Shutdown	Y, ENABLE FEATURE OR FUNCTION	N/A
Engine Protection Restart Inhibit	Y, ENABLE FEATURE OR FUNCTION	N/A
Engine Prot Coolant Level Shutdown	N, DISABLE FEATURE OR FUNCTION	N/A
Sudden Veh Speed Decel Threshold	6.96	MPH
Trip Information Vehicle Ovrsped1	74	MPH
Trip Information Vehicle Ovrsped2	76	MPH
Veh Speed Sensor Anti Tamper Level	1, HIGH LEVEL	N/A
Maintenance Monitor Enable	N, DISABLE FEATURE OR FUNCTION	N/A
Maintenance Monitor Operating Mode	0, MAINTENANCE MONITOR AUTOMATIC MODE OF OPERATION	N/A
Maintenance Monitor Alert Percent	90	%
Maintenance Monitor Distance	15000	MILES
Maintenance Monitor Fuel	2000	GALLONS
Maintenance Monitor Time	500	HOURS
Maintenance Monitor Interval Factor	1.00	N/A
Master Password	000000	N/A
Adjustment Password	000000	N/A
Reset Password	000000	N/A
Predictive Gear Shifting	N, DISABLE FEATURE OR FUNCTION	N/A

These Electronic Parameters have not been finalized

<u>Description</u>	<u>(US DOLLAR)</u>	<u>Price</u>
Factory List Prices:		
Product Items	\$144,547.00	
Service Items	\$0.00	
Total Factory List Price Including Options:		\$144,547.00
Total Goods Purchased:		\$5,753.74
Total Preparation And Delivery:		\$1,760.00
Freight	\$3,100.00	
Total Freight:		\$3,100.00
Total Factory List Price Including Freight:		\$155,160.74
Less Customer Allowance:		(\$66,695.31)
Total Vehicle Price:		\$88,465.43
Total Sale Price:		\$88,465.43
Total Per Vehicle Sales Price:		\$88,465.43
Total Net Sales Excluding Taxes:		\$88,465.43
Michigan Title Fee	\$15.00	
Total License, Title:		\$15.00
Net Sales Price:		\$88,480.43

** Note additional Surcharges may apply as issued by the manufacturer**

Payment for the chassis is due upon delivery of the cab/chassis to the end user or body company; which ever occurs first. If payment is not received in a timely manner additional floorplan(interest) costs may be charged to the end-user customer.

Please make all purchase orders and checks payable to:
Tri-County International Trucks, Inc.
5701 Wyoming Ave.
Dearborn, MI 48126

Please review this proposal very carefully. Your signature below indicates that you accept the specifications and payment terms, contained herein as written and that you are able to approve said specifications for order and payment terms. Please include this proposal number on all correspondence and purchase orders.

Approved by Seller:

Accepted by Purchaser:

Official Title and Date

Firm or Business Name

Authorized Signature

Authorized Signature and Date

TRI COUNTY INTL TRUCKS
3001 E HIGH ST
JACKSON MI 49203
(517)783-2721

This proposal is not binding upon the seller without Seller's Authorized Signature

Official Title and Date

The TOPS FET calculation is an estimate for reference purposes only. The seller or retailer is responsible for calculating and reporting/paying appropriate FET to the IRS.

The limited warranties applicable to the vehicles described herein are Navistar, Inc.'s standard printed warranties which are incorporated herein by reference and to which you have been provided a copy and hereby agree to their terms and conditions.

TRUCK & TRAILER *Specialties, Inc.*

900 Grand Oaks Drive | Howell, MI 48843 | www.ttspec.com | ph: (517) 552-3855 | fx: (517) 552-3666

June 23, 2023

City of Marine City
514 S. Parker Street, Marine City, MI 48039
Attn: Mike Itrich, DPW Superintendent, ph: (810) 676-5269
HQ0003599



State Contract Hyperlink No: [20000000034](#)

Equipment Quotation utilizing the state contract awarded to Truck & Trailer Specialties, Inc.

Install Crysteel 10' Select Dump Body including the following:

- 120" length, 84" inside width
- 50" front height, 30" side height and 36" rear (6.5-8 cubic yard capacity water level)
- Single panel, pressed-in horizontal side braces
- 7-gauge 201 stainless steel front, sides & rear pillars
- ¼" AR450 floor
- 8" floor-to-sides radius
- 8" I-beam type crossmemberless understructure
- 14" wide rear pillar
- Air-operated tailgate
- 6-panel tailgate design constructed of 7-gauge 201 stainless steel
- 1/2 cabshield constructed of 10-gauge 201 stainless steel
- Body prop kit on each side of the frame
- Install 8" hardwood sideboards (8 cubic yards with sideboards)
- Install 3-hole light wedges on rear pillars for lighting
- Install branch deflector on cabshield, curbside
- Install fixed step streetside-mounted front of dump with cabshield grab handle
- Install two (2) shovel holders on the streetside of dump bulkhead
- Install license plate brackets in upper-left corner of tailgate

Install Mailhot model G490-4.25-3 DA Telescopic Hoist including the following:

- Greaseable rear hinge and replaceable rear stainless steel pin
- Hoist is double-acting and trunnion-mounted
- Install remote grease extension kit for hoist fittings and oscillating collar

Install Roll-Rite Electric Tarp System including the following:

- Direct-drive motor with aluminum wind deflector
- Aluminum tarp and tension bows
- 3-spring tarp arms with offset arms
- Mesh-type tarp cover
- In-cab control

Install Central Hydraulic System including the following:

- Rexroth A10VO85** front-mounted load-sensing piston pump
- Low-oil shutdown system with shutdown/override switch installed in armrest console
- Spicer drive line with companion flange for easy removal

Install Central Hydraulic System including the following:

- 32-gallon Slimline oil reservoir constructed of steel with tank-mounted filter
- Ball valve shut-off on supply port and a sight/temp gauge on the end of the tank

TRUCK & TRAILER *Specialties, Inc.*

900 Grand Oaks Drive | Howell, MI 48843 | www.ttspec.com | ph: (517) 552-3855 | fx: (517) 552-3666

Low oil sensor in tank

All necessary hoses and fittings

Tank painted Black or to match cab

Install Rexroth 5m4-12 closed-center air control hydraulic valve with the following sections:

Air-operated section for scraper up/down

Air-operated section for scraper swing

Air-operated section for dump hoist with 500 PSI A-port load-sense limit

EPC section for spinner

EPC section for auger

Above valve within above frame-mounted stainless steel combo tank enclosure

Apsco air-type single axis levers for a total of 3 levers in position (L-R) from driver:

#1 Scraper up/down

#2 Scraper left/right

#3 Dump Hoist up/down with safety detent

Install stainless steel pipe to the rear for spreader circuits

Install stainless steel quick couplers for spreader circuits with dust caps & plugs

All necessary hoses and fittings

Install Rexroth CS620 Electric Spreader Controller including the following:

Programmed to operate with groundspeed orientation in manual mode

Push-button dials for pause & blast features

Data download available and programming is with a thumb drive

Controller mounted between the seats elevated on a console

Remote pause & blast large toggle switch installed in console

Install 12" Channel Front Bumper with tapered ends including the following:

Bumper cut-outs with front tow hooks installed on frame rails

Install Monroe 10' model MS4510 Underbody Scraper including the following:

1" thick x 20" high moldboard

½" thick hanger board with grease manifold brackets installed

2-1/2" O.D. hinge shaft

Two heavy-duty shock absorbers

Bolt-in trunnion caps for canisters; Outer arm remains bolt-on style

Two 3-1/2" x 10" actuating cylinders; Socatri rods

Cushion valve

1" solid circle with 5" center pin

Center pin is piloted into hanger board

Two 4" x 12" reversing cylinders; Socatri rods

Three hinge anchor points

Hydraulic pipes

20.5" x 7" poly hold-down blocks

Mounting hardware

Parts-installation manual

Hose kit and j-50 type relief valve

¾" solid hanger plates

Grease line kit with manifolds

Standard cutting edges

Install one (1) Kennametal carbide curbguard on curbside

Install serrated safety step on end of moldboard, streetside

Paint Hi-Viz Yellow bands on both ends of moldboard

Install Monroe model MS966-OW-GB Undertailgate Spreader including the following:

TRUCK & TRAILER *Specialties, Inc.*

900 Grand Oaks Drive | Howell, MI 48843 | www.ttspec.com | ph: (517) 552-3855 | fx: (517) 552-3666

Type 201 stainless steel construction
Stainless steel anti-flow cover and spill kit included
6" auger with one-way flighting and 4" flight spacing for left-end discharge
5:1 gear box with direct-mounted motor
Spinner motor includes a seal-saver kit with grease zerk
Trough-hung self-leveling spinner with 18" poly spinner disc
Extended integral side plates on spreader
Jumper hoses with stainless steel hydraulic couplers

Install Custom Lighting & Electrical including the following:

OEM chassis switches will be wired to:

1. Flashers
2. Scraper Light
3. Spreader Light
4. Air Tailgate

Console switches for: Tarp open/Tarp close & Pump shutdown/override
Heads-up Display with Indicator lights on dash for: Tailgate open, Low-oil, Body-up & Pump shutdown
One (1) SoundOff Pinnacle (mo. EPL7PDPC) amber/green mini lightbar with guard on front of cabshield
Four (4) SoundOff mPower (mo. EMPS20V38-P) amber/green LED flashers flush-mounted including:
Two (2) front-facing at upper corners of cabshield
Two (2) side-facing at bottoms of cabshield
Two (2) 3-hole 6" oval stainless steel light wedge boxes welded on rear pillar posts including:
Two (2) SoundOff nForce (mo. ENFSLSRV12) LED amber/green flashers in top holes
Two (2) SoundOff LED STT lights in 2nd holes
Two (2) SoundOff LED backup lights in 3rd holes
One (1) 4" Maxxima LED work light mounted curbside above the scraper
One (1) 4" Maxxima LED work light mounted at streetside rear for spreader
LED marker light kit for dump body
Proximity switch mounted under dump for body-up
Betts junction box mounted at rear of the dump body
Back-up alarm

Install Pintle Hitch assembly including a 3/4" thick steel mounting plate including the following:

PH-20 Pintle hitch with multi-drill holes for adjustable mounting
Heavy-duty safety "D" rings
Rear tow hooks mounted outside of rear hitch plate
6-way round trailer plug

Install Minimizer Floor Mats for International HV607 (mo. FKINTL3B-MIN / 10002433)

Install Mudflaps in front of and behind drive tires

Paint Bottom of the body, body hinge, body props, front & rear hitches & attaching hardware painted Black

Minimum full 1-year warranty on parts and labor on all equipment.

Above installed equipment, non-stainless painted pricing: \$91,325.00 ea.

Chassis requirements to be confirmed at time of order:

International HV607

CA: 102"

Front of engine PTO provision

Delete OEM bumper

TRUCK & TRAILER *Specialties, Inc.*

900 Grand Oaks Drive | Howell, MI 48843 | www.ttspec.com | ph: (517) 552-3855 | fx: (517) 552-3666

Front crossmember for pump mounting
Front frame extension
Undercab horizontal DPF and SCR with vertical tail pipe
Highest ground clearance package for Underbody Scraper
Trailer wiring to the rear
Stationary grille
50-gallon fuel under driver's door
Chassis 6-pack of switches

Payment Terms: Net 30. Pricing effective for 30 days.

FOB: City of Marine City

Delivery: Depending on chassis arrival, to be determined

T and T can't order equipment until INT chassis has a vin # attached. At that point, we would update to current pricing confirm with Marine city and order equipment based on Truck manufacture delivery schedule. The goal would be to align and coordinate equipment delivery and chassis completion at the same time. Leadtime on equipment is 300 days

Thank you for the opportunity to quote.

Respectfully submitted by,
Jon Luea/Brian Bouwman

BioTech Agronomics, Inc.



Residual Management Company

1651 Beulah Highway • Beulah • Michigan • 49617

July 5, 2023

CONTRACT FOR TESTING, REMOVAL AND LAND APPLICATION OF BIOSOLIDS FOR THE CITY OF MARINE CITY WASTEWATER TREATMENT PLANT

City of Marine City
260 S. Parker Street
Marine City, Michigan 48039

Proposal

BIOTECH AGRONOMICS, INC. is pleased to present this proposal to define proposed work associated with the removal and land application of Biosolids generated by the Marine City WWTP located at 1696 S. Parker St., in Marine City, Michigan.

Biosolids Loading and Transport

BIOTECH AGRONOMICS, INC. will furnish the necessary labor and equipment to efficiently and safely provide Biosolids Management services for the Marine City WWTP. BIOTECH AGRONOMICS, INC. will pump and load Biosolids into transport vehicles, transport the Biosolids to EGLE and federally approved application sites, and finally to land apply the Biosolids to suitable local farmland sites. All work performed will be under Michigan Part 24, Federal 503 and local regulations.

Land Application of Biosolids

BIOTECH AGRONOMICS, INC. will provide the labor and equipment to properly apply the Biosolids to suitable local application sites at agronomic rates in accordance with Michigan State University recommendations and applicable federal, state and local regulations. The Biosolids will be subsurface injected or surface applied according to a EGLE approved Residuals Management Plan using sewage sludge applicators equipped with a pressure/vacuum application system.

Determination of Quantity Removed

BIOTECH AGRONOMICS, INC. shall provide the Plant Superintendent a duplicate copy of load sheets, which detail the following items:

- Date of removal
- Time the applicator loaded in the field
- Applicator identification number
- Operator name
- Gallons of Biosolids on the applicator
- Farmer name and approved field identification number and the number of acres acceptable for use in the field
- Number of acres accepting Biosolids

One copy of the load sheet(s) will stay with the plant superintendent and the other will remain with BIOTECH AGRONOMICS, INC. The quantity of Biosolids loaded on and transported by the vehicle will be recorded as the certified capacity of the vehicle. All billed quantities will be invoiced by the gallon capacity of each vehicle transporting the material.

Agronomic Services

BIOTECH AGRONOMICS, INC. will provide agronomic management services that include the location of suitable local farmland application sites. Application sites will meet the requirements for land application in accordance with applicable federal, state and local regulations for the use and disposal of Biosolids. Proposed farmland application sites shall be properly documented in accordance with Michigan Part 24 requirements. Records at a minimum shall include the following:

- Landowner agreement and permission form
- Soil analyses
- EGLE site I.D. information
- Plat maps indicating location and ownership of property
- SCS or equivalent soil survey map indicating soil types, slope and drainage class
- Relative sludge analyses, soil analyses or cropping information
- Proof of notification to local governing bodies as per EGLE requirements

Regulatory Reports

BIOTECH AGRONOMICS, INC. shall complete all required federal or state reports applicable to the Biosolids land application program including yearend requirements. These records shall be maintained by BIOTECH AGRONOMICS, INC. as required by federal, state and local regulations and shall be provided to the Owner.

Laboratory Analyses and Permits

BIOTECH AGRONOMICS, INC. will be provided a EGLE approved Residuals Management Plan (RMP) by the facility. BIOTECH AGRONOMICS, INC. will provide laboratory analyses for total metals and nutrients and fecal coliform testing as needed on the Biosolids prior to removal from the facility. BIOTECH AGRONOMICS, INC. will be responsible for all routine soil fertility analyses associated with land application of the Owner's Biosolids during the term of this Agreement. BIOTECH AGRONOMICS, INC. shall not be responsible for any additional analytical testing that federal, state or local regulatory agencies may require.

Health and Safety

BIOTECH AGRONOMICS, INC. shall comply with the federal, state and local laws and regulations and take any needed actions to protect the life and health of employees on the job and the safety of the public and to protect property during the performance of the Agreement.

Insurance

BIOTECH AGRONOMICS, INC. shall provide and maintain at all times during the term of this Agreement the following minimum insurance coverage:

- a) Workers Compensation Insurance in compliance with the statutes of the State of Michigan which has jurisdiction of BIOTECH AGRONOMICS, INC. employees engaged in the performance of services hereunder with a limit of FIVE HUNDRED THOUSAND DOLLARS (\$500,000)
- b) General Liability Insurance with a minimum combined single limit of THREE MILLION DOLLARS (\$3,000,000), including the broad form property damage endorsement
- c) Automobile Liability Insurance (owned, non-owned or hired units) with a minimum combined single coverage limit of ONE MILLION DOLLARS (\$1,000,000)

- d) Pollution Liability Insurance with a minimum combined single limit of FIVE MILLION DOLLARS (\$5,000,000), including the broad form property endorsement

A certificate of insurance will be presented if requested, upon award of contract.

Digester or Tank Cleaning

If requested, BIOTECH AGRONOMICS, INC. will provide confined space Digester or Tank cleaning services to remove accumulated Biosolids and or related mater for subsequent land application. Under these conditions, the WWTP shall provide for all required cleaning water at no cost to BIOTECH AGRONOMICS, INC. Any material removed under this confined space option shall be billed at the appropriate hourly rate plus the unit rate per gallon for land application of the Biosolids.

Biosolids Tender

The City shall tender all biosolids generated to BIOTECH AGRONOMICS, INC. that are suitable for land application on agricultural land as specified in the scope of this Agreement.

Notification

BIOTECH AGRONOMICS, INC. will be provided with adequate advance notice of when the WWTP desires for BIOTECH AGRONOMICS, INC. to remove biosolids from the WWTP. Depending on weather, seasonal weight restrictions, and farm land cropping cycles, additional notification may be required.

Cost of Services

Year 2023 - \$0.0631 per gallon for Biosolids hauling and land application.
Metals & Nutrients Testing - \$488.00 per sample.
Fecal Coliform Testing - \$450.00 each set of seven replicates.
Optional PFAS Testing: \$825.00 per sample
Optional Tank Cleaning Services - \$500.00 per hour.

Year 2024 - \$0.0631 per gallon for Biosolids hauling and land application.
Metals & Nutrients Testing - \$488.00 per sample.
Fecal Coliform Testing - \$450.00 each set of seven replicates.
Optional PFAS Testing: \$825.00 per sample (one required annually)
Optional Tank Cleaning Services - \$500.00 per hour.

Year 2025 - \$0.0649 per gallon for Biosolids hauling and land application.
Metals & Nutrients Testing - \$495.00 per sample.
Fecal Coliform Testing - \$465.00 each set of seven replicates.
Optional PFAS Testing: \$830.00 per sample (one required annually)
Optional Tank Cleaning Services - \$520.00 per hour.

Year 2026 - \$0.0668 per gallon for Biosolids hauling and land application.
Metals & Nutrients Testing - \$499.00 per sample.
Fecal Coliform Testing - \$473.00 each set of seven replicates.
Optional PFAS Testing: \$830.00 per sample (one required annually)
Optional Tank Cleaning Services - \$530.00 per hour.

Good Faith

In the event BIOTECH AGRONOMICS, INC. is unable to remove and land apply the biosolids because (i) changes in the biosolids make it unfit for utilization on agricultural land as defined or interpreted by federal, state or local regulatory agencies, or (ii) changes in law prohibit providing the services or increase the cost of providing the services, or (iii) if unfavorable climatic or agronomic conditions have impeded efforts by BIOTECH AGRONOMICS, INC. to faithfully dispose of the biosolids as contemplated by this proposal, or (iv) as the result of flood, fire, strikes, acts of God, act of war or terrorism, civil disturbance, force majeure, or other occurrences not reasonable within the province and control of BIOTECH AGRONOMICS, INC. performance is hindered or halted, BIOTECH AGRONOMICS, INC. shall not be liable for any additional costs incurred by Caledonia Township, and BIOTECH AGRONOMICS, INC. will not be deemed in default under this proposal unless thirty (30) days after the impediment has been resolved or eliminated BIOTECH AGRONOMICS, INC. fails or refuses to remove biosolids tendered to it.

BIOTECH AGRONOMICS INC work schedule is highly controlled by weather, soil conditions, permits and the availability of suitable farmland due to cropping cycles. As such we cannot liable for any losses either directly or indirectly associated with any weather related delays. BIOTECH AGRONOMICS, INC will not accept responsibility for any assessment of liquidated damages.

Spill Plan and Protocol

BIOTECH AGRONOMICS, INC. has a strict protocol to be followed in the untimely event of a spill. If such an event occurs the person in charge of the load, the operator of the application equipment, load stand operator or truck driver, must contact their immediate supervisor after making a visual assessment of the action and if possible taking action to contain or correct the problem. The supervisor is to contact the BIOTECH AGRONOMICS, INC. Operations Manager and the chain of contacts begins. The plant personnel are informed and an assessment will be done by personnel from both entities. At this time the decisions will be made to contact local authorities, EGLE representative, additional emergency services and so on depending upon severity. All the above continues while the containment efforts are addressed. All assets and efforts of BIOTECH AGRONOMICS, INC. will be focused on cleanup and rectifying the problem to protect the health and safety of the public.

Fuel Cost and Adjustment

BIOTECH AGRONOMICS, INC. shall adjust the cost of services for each hauling event should fuel costs exceed \$4.00 per gallon. The fuel adjustment schedule will be the fixed document used for such purpose throughout the duration of this contract.

The unit price for biosolids management beneficial use services for any given removal operation will be subject to the adjustment below depending on the weekly fuel price (based on the week biosolids removal commences) determined by the United States Department of Energy's Energy Information Administration publication of Retail Prices for the Midwest United States in the On-Highway Diesel Fuel Price Table.

Diesel Price \$/Gallon	% Increase to Contract Price
Below \$4.00	None
\$4.00 - \$4.099	1.0%
\$4.10 - \$4.199	2.0%
\$4.20 and above = 1% increase per each \$0.10 increase in price/gallon.	

(This information is available at the website <http://www.eia.doe.gov>). (On-Highway Diesel Prices Table – Midwest Column)

Terms

Payment terms shall be net 30 days from the date of invoice. Overdue payments will be assessed a finance charge of 1.5% per month on the unpaid balance.

Contract Duration

This Agreement shall remain in full force and effect from 9/1/2023 through 12/31/2026.

Extensions

The term of this Agreement may be extended for one (1) additional three (3) year term upon mutual agreement of both parties.

BIOTECH AGRONOMICS, INC.

Submitted by: *Don Popma*

Printed Name: Don Popma

Its: General Manager

Date: July 5, 2023

CITY OF MARINE CITY, MICHIGAN.

Accepted By: _____

Printed Name: _____

Its: _____

Date: _____

This document is representative of a complete contract. Upon award the document can be signed by both parties to become binding.