



CITY OF MARINE CITY

Historical Commission Meeting Agenda

Guy Community Center, 260 South Parker Street

Special Meeting: Wednesday, June 1, 2022; 5:00 PM

1. **CALL TO ORDER**
2. **PLEDGE OF ALLEGIANCE**
3. **ROLL CALL:** Chairperson Kim Turner; City Commissioner Brian Ross; Commissioners William Beutell, Suzanne Jenken, Rosalie Skwiers, Scott Tisdale, Andrew Pakledinaz; City Manager Holly Tatman
4. **COMMUNICATIONS**
5. **APPROVE AGENDA**
6. **PUBLIC COMMENT** *Anyone in attendance is welcome to address the Historical Commission. Please state name and limit comments to five (5) minutes.*
7. **APPROVE MINUTES**
 - A. Historical Commission Regular Meeting – April 19, 2022
8. **UNFINISHED BUSINESS**
9. **NEW BUSINESS**
 - A. Bandstand Construction at 300 Broadway
 - Pouring of concrete slab/handrail/ramp installation
 - Upgrading electrical box to 100 amp service
 - Building and electrical permits
 - B. Select Member for 300 Broadway Committee
10. **ADJOURNMENT**

**City of Marine City
Historical Commission Meeting
April 19, 2022**

A regular meeting of the Historical Commission was held on Tuesday, April 19, 2022 and was called to order by Chairperson Kim Turner at 5:04 pm.

Present: Chairperson Kim Turner, City Commissioner Brian Ross, Commissioners Scott Tisdale, Suzanne Jenken, Andrew Pakledinaz; City Manager Holly Tatman; City Clerk Shannon Adams

Absent: Commissioner William Beutell and Commissioner Rosalie Skwiers

Motion by City Commissioner Ross, seconded by Commissioner Pakledinaz, to excuse Commissioner Beutell and Commissioner Skwiers from the meeting. All Ayes. Motion Carried.

Approve Agenda

Motion by City Commissioner Ross, seconded by Commissioner Pakledinaz, to approve the Agenda. All Ayes. Motion Carried.

Approve Minutes

Motion by Commissioner Tisdale, seconded by City Commissioner Ross, to approve the minutes from the January 18, 2022 Historical Commission meeting. All Ayes. Motion Carried.

Communications

None.

Public Comment

None.

Unfinished Business

Resolution to Recognize 300 Broadway as a City Park

Chairperson Turner brought in an original plat paper from Saint Clair County and an 1854 plot map of the City, both from the museum. City Commissioner Ross identified on the

plat paper that lot 18 block 43 was what is now known as 300 Broadway and the plot map also supported this identification which Chairperson Turner verified was correct. The map the lot identified was designated a park.

She further explained that it appeared that Samuel Ward, founder of Newport, now known as Marine City, had given a piece of land to the City, though it was unclear what he received for compensation. City Commissioner Ross indicated that Planning Commission Chairperson Moran was open to revisiting the Master Plan to add 300 Broadway back in as a park and City Manager Tatman verified that there were funds included in the coming fiscal year to do so. Chairperson Turner stated that she would like the Historical Commission to recognize 300 Broadway as a park by adopting a Resolution. City Manager Tatman advised that if a Resolution were adopted by the Historical Commission, it would need to be sent to the City Commission to be voted on and adopted.

City Manager Tatman also informed the Historical Commission that the Workgroup for City Owned Properties recommendation related to 300 Broadway was that the City retain ownership of 300 Broadway, and that it would be voted on at the next City Commission meeting. City Commissioner Ross also indicated a need to communicate with Wade Trim related to updating the Zoning Maps to indicate where the Historic District was located. Chairperson Turner stated that there was a previous investigation done related to expanding the Historic District that needed to be revisited.

Motion by Commissioner Pakledinaz, seconded by Commissioner Tisdale, to adopt the Resolution to recognize 300 Broadway as a park to be added back into the Master Plan and to forward the Resolution to the City Commission. **Roll Call Vote.** Ayes: Turner, Jenken, Ross, Tisdale, Pakledinaz. Nays: None. Motion Carried.

New Business

Proposed Updates to Certificate of Appropriateness/Notice to Proceed

Chairperson Turner addressed an issue related to the Certificate of Appropriateness/Notice to Proceed form and the discrepancy related to the time the applicant had to complete a project. She verified the State's procedures which indicated there was a one year time period versus a 90-day time period as stated on the form, therefore it needed to be corrected. She further explained that this form was used after a permit was issued and approval granted for a property owner to do work on their property located in a historic district. Chairperson Turner also proposed adding an appropriate header with the City seal on the form in conformity with others available from the City. Chairperson Turner pointed out that the City Clerk's name needed to be corrected on the form as well.

Motion by Commissioner Tisdale, seconded by City Commissioner Ross, to update the Certificate of Appropriateness/ Notice to Proceed form to correct discrepancies related to the time to complete a project, the City Clerk's name, and to add a header. All Ayes. Motion Carried.

Adjournment

Motion by Commissioner Ross, seconded by Commissioner Pakledinaz, to adjourn at 5:37 pm. All Ayes. Motion Carried.

Respectfully submitted,

Shannon M. Adams
City Clerk

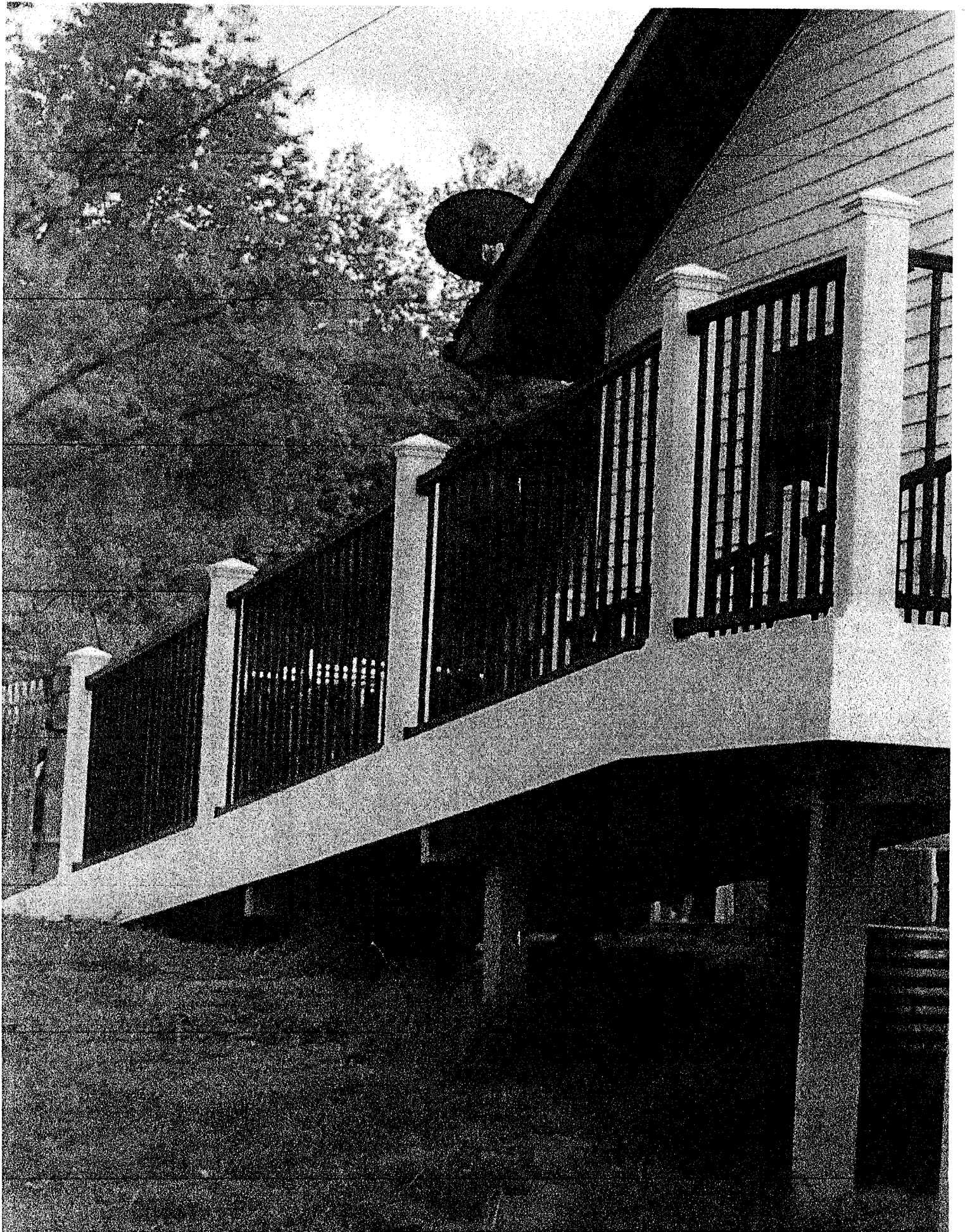

Marine City Hall Handicap Ramp

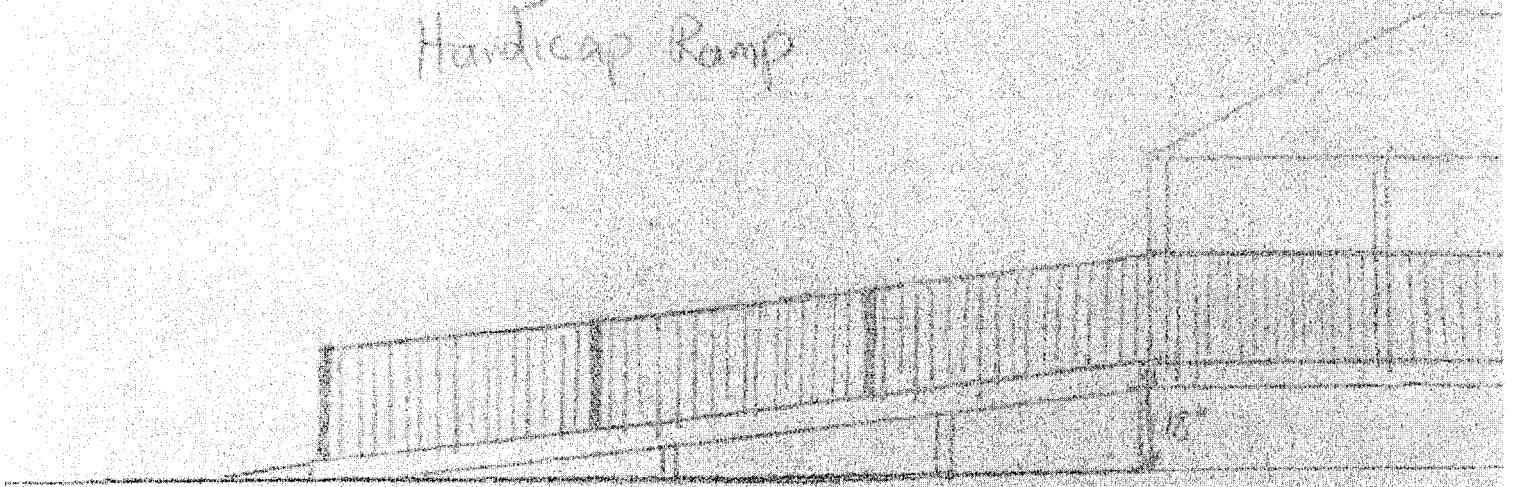

Ramp elevation
18" off gra

36" handrail h

Trex Deck
Trex Alumi

1/4" scal

ESTIMATE

Frank Trucano



Decked Out Building LLC

Clay Twp, Mi 48001

Phone: (586) 242-3404

Email: krisrients@gmail.com

Estimate #

000239

Date

04/26/2022

Description	Total
18 ft x 8 ft handicap ramp Trex with aluminum rail	\$9,360.00

Subtotal	\$9,360.00
Total	\$9,360.00
Deposit Due	\$4,680.00

We can increase the size to 20'
without moving the sprinkler manifold or spotlight.

Increase of floor area from 153 sq/ft -to- 314 sq/ft.

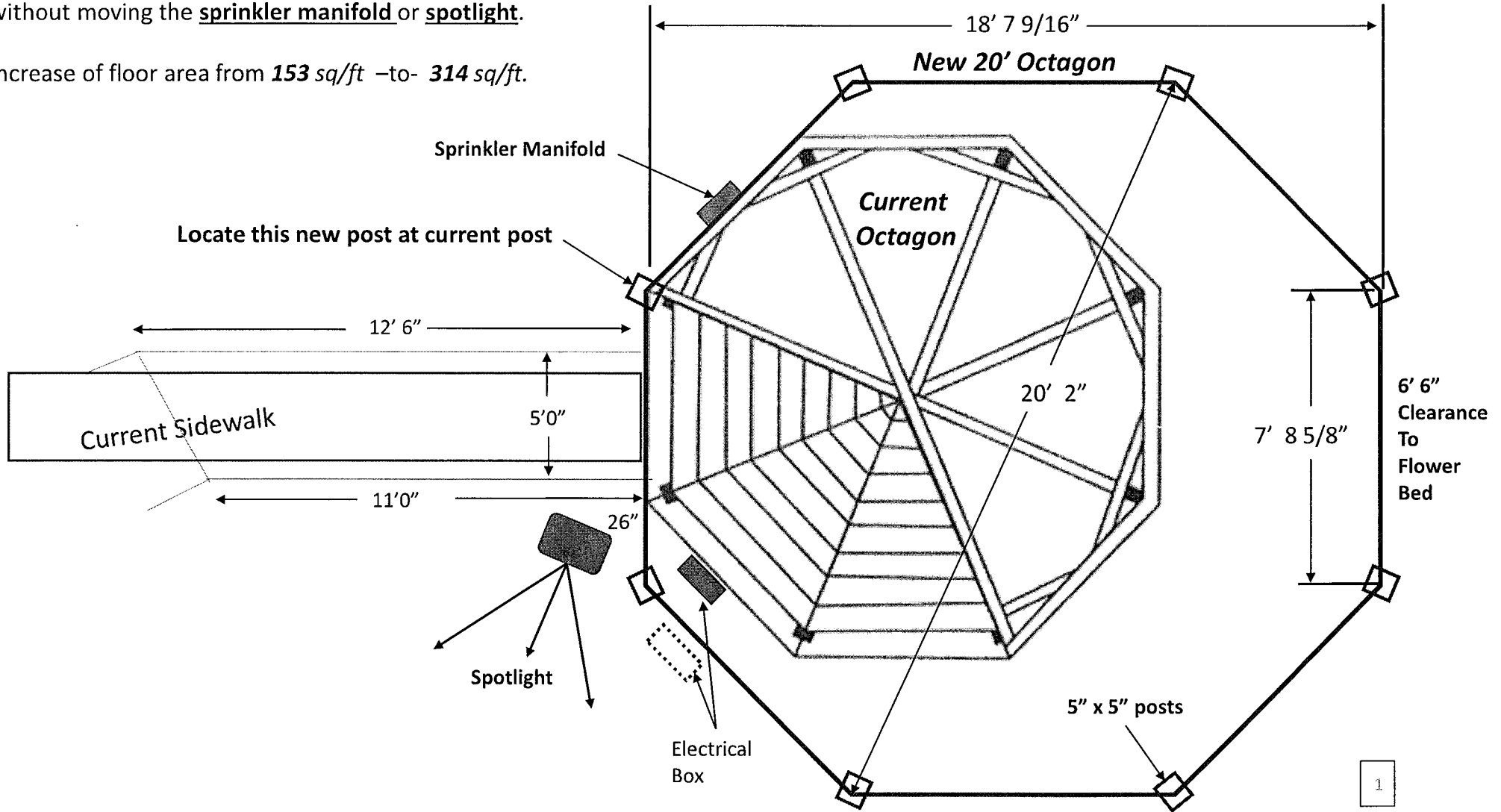

Floor Section

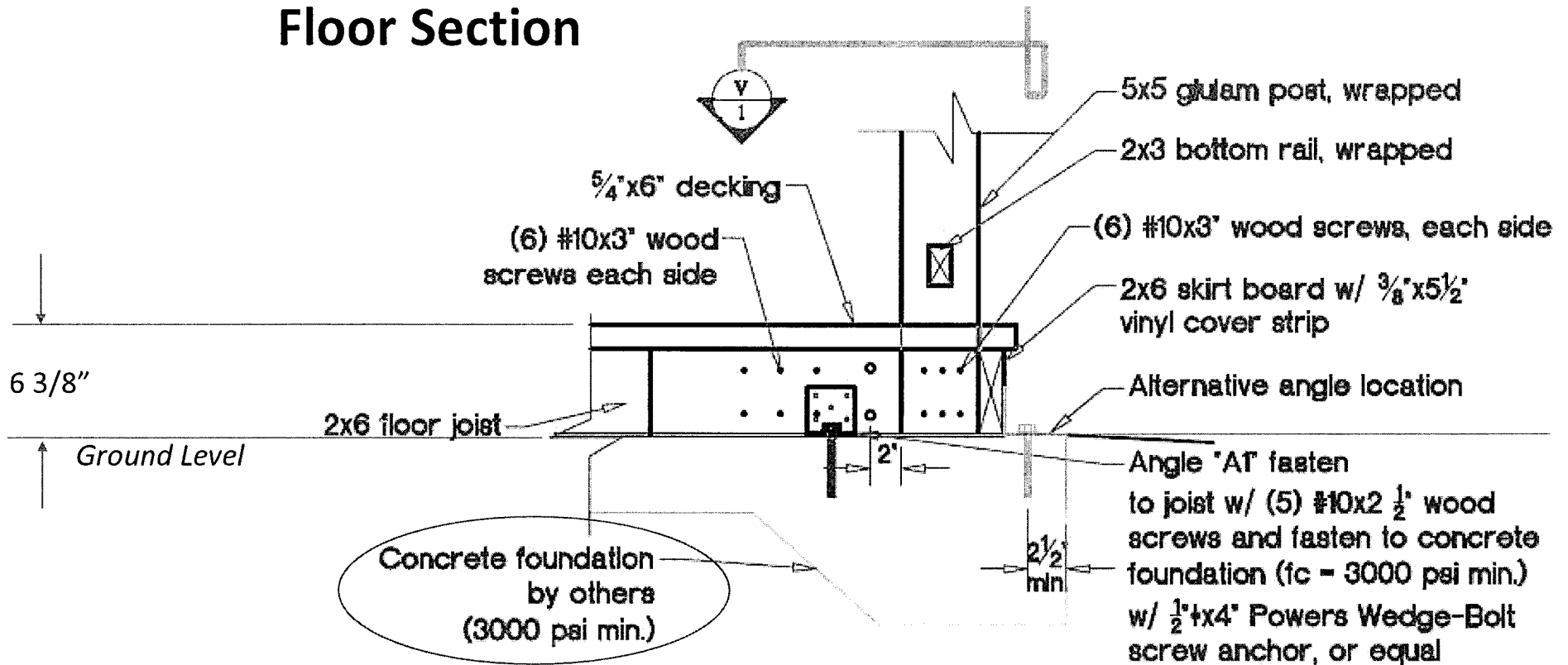

Detail C-C/6

NTS

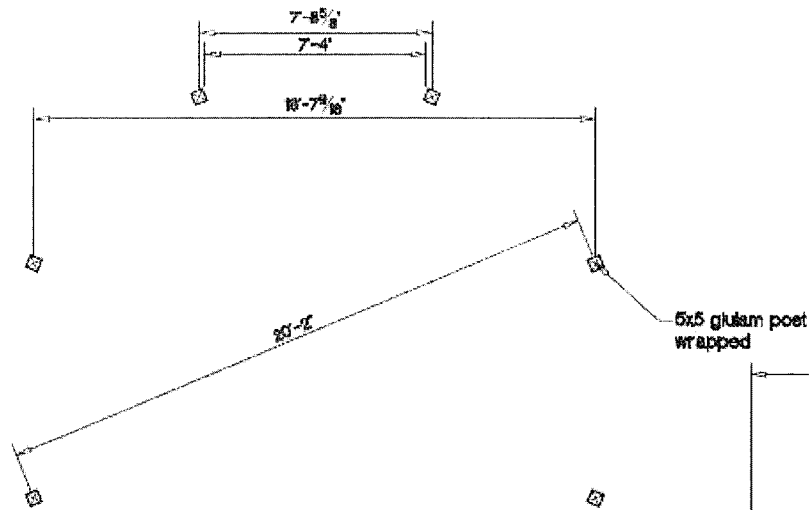

Post Layout Plan NTS

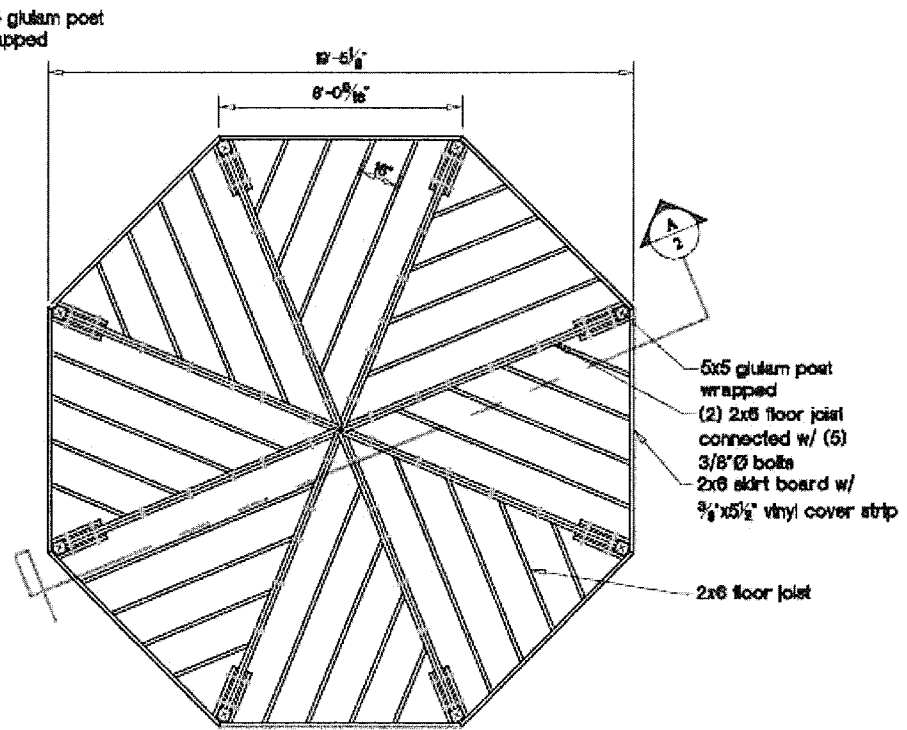

Floor Framing Plan NTS

- 5x5 glulam post wrapped
- (2) 2x6 floor joist connected w/ (5) 3/8"Ø bolts
- 2x6 skirt board w/ 3/8"x5 1/2" vinyl cover strip
- 2x6 floor joist

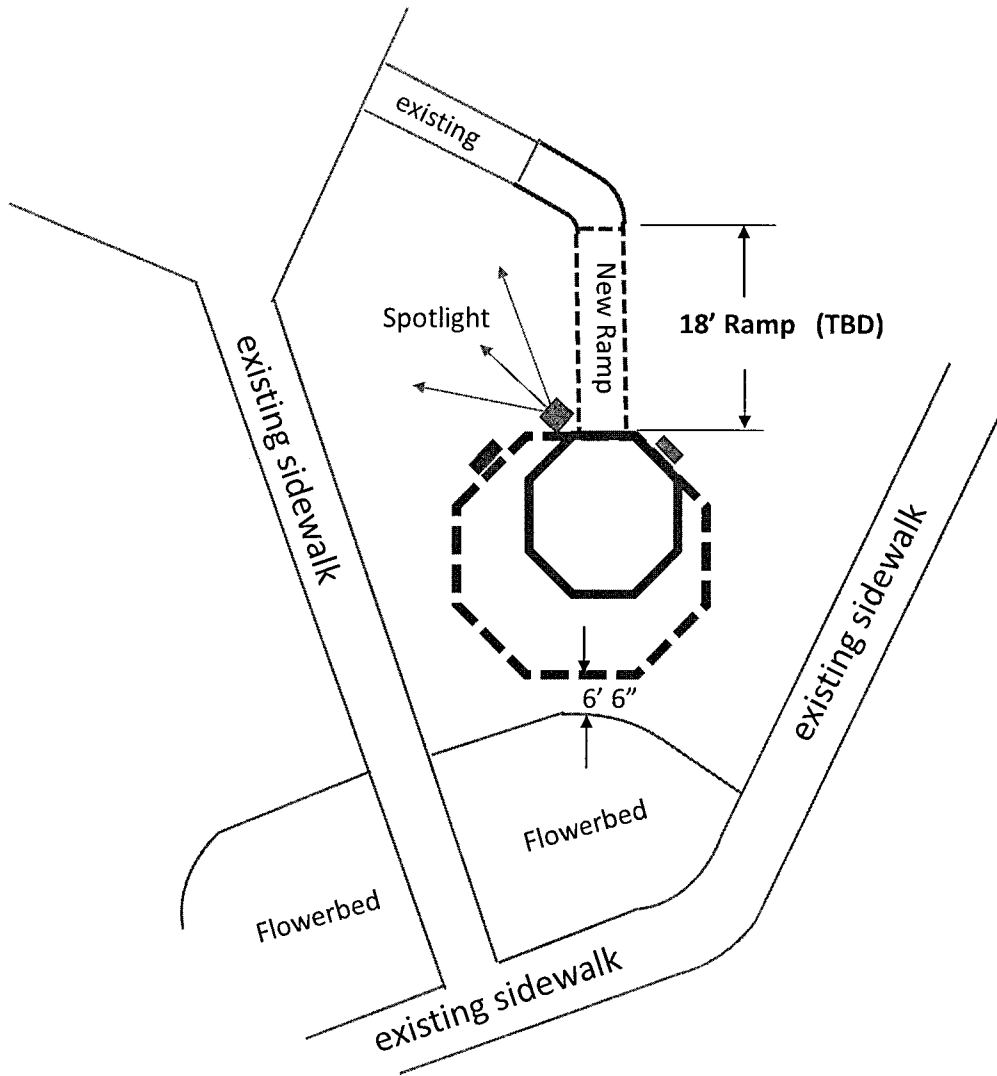

ADA Wheelchair Ramp

18' of lead for an 18" floor raise.
36" wide inside of handrails.

ADA ramp angle

For every inch you raise the floor.
You need twelve inches of lead.

